

Triple Play Access Concentrator

SAGEM 3P@C 4450E

Next Generation DSLAM

HARDWARE INSTALLATION MANUAL

Issue November 2004



Triple Play Access Concentrator

SAGEM 3P@C 4450E

Next Generation DSLAM

HARDWARE INSTALLATION MANUAL

Issue November 2004



WARNING

The information in this document covers a version of the system designated SAGEM 3P@C 4450E. It is subject to technical changes.

The different versions of the manual will follow changes to the equipment.

RECORD OF AMENDMENTS

(Each new edition supersedes the previous edition)

<i>EDITION N°</i>	<i>DATE</i>	<i>PURPOSE OF UPDATES</i>	<i>PAGES</i>
1	November 2004	Creation of the document	All pages

FOREWORD

You have just acquired a product which has been developed using the very latest technologies and *SAGEM SA* know-how. *SAGEM* thanks you for your confidence in their products.

TABLE OF CONTENTS

Use Guide to This Manual	13	
Part I 16		
1. Overview of the 3P@C 4450E IP-DSLAM	1-1	
1.1. SYSTEM OVERVIEW		1-1
1.2. REPRESENTATIVE NETWORKING APPLICATIONS		1-1
1.3. SYSTEM COMPOSITION		1-2
1.4. HARDWARE FEATURES		1-3
2. 3P@C 4450E Hardware Structure	2-1	
2.1. SHELF CONFIGURATION		2-1
2.1.1. <i>Structure of the General Chassis</i>		2-1
2.1.2. <i>10U Chassis</i>		2-3
2.1.3. <i>Fan Module</i>		2-4
2.1.4. <i>Air Deflector Frame</i>		2-4
2.2. FULL CONFIGURATION OF THE CABINET		2-6
2.3. SMUB AND SERVICE BOARDS		2-7
2.3.1. <i>Service Processor Unit Board (SMUB)</i>		2-7
2.3.2. <i>VDSL Unit Board (VDUB)</i>		2-10
2.3.3. <i>ADSL Unit Board (ADUB)</i>		2-11
2.3.4. <i>ADSL Unit Card (ADUC)</i>		2-13
2.4. POWER DISTRIBUTION SYSTEM		2-14
2.4.1. <i>Overview</i>		2-14
2.4.2. <i>Functional Features</i>		2-14
2.5. OPTIONAL UPLINK INTERFACE MODULES		2-15
2.5.1. <i>1-port Gigabit Long-wave Optical Interface Module (DS-1GLX)</i>		2-15
2.5.2. <i>1-port Gigabit Short-wave Optical Interface Module (DS-1GSX)</i>		2-17
2.5.3. <i>2-port 100M Multi-mode Optical Interface Module (DS-2FMM)</i>		2-18
2.5.4. <i>2-port 100M Single-mode Optical Interface Module (DS-2FSM)</i>		2-19
2.5.5. <i>4-port 100M Electrical Interface Module (DS-4TXB)</i>		2-21
2.5.6. <i>VAS Card (DS-4ITX)</i>		2-22
2.6. ROUTE TRANSFER UNIT (RTU)		2-23
3. Installation Preparation	3-1	
3.1. ENVIRONMENTAL REQUIREMENTS		3-1
3.1.1. <i>Temperature and Humidity Requirements</i>		3-1
3.1.2. <i>Cleanness Requirements</i>		3-1
3.1.3. <i>Floor Requirements</i>		3-1

3.1.4.	<i>Heat Dissipation Requirements</i>	3-2
3.1.5.	<i>Power Supply Requirements</i>	3-2
3.1.6.	<i>Grounding Requirements</i>	3-2
3.1.7.	<i>Anti-interference Requirements</i>	3-4
3.1.8.	<i>Other Requirements</i>	3-4
3.2.	SAFETY REQUIREMENTS	3-5
3.2.1.	<i>Basic Safety Requirements</i>	3-5
3.2.2.	<i>Antistatic Requirements</i>	3-5
3.2.3.	<i>Avoiding Laser Damage</i>	3-6
3.2.4.	<i>Lightning Protection Requirements</i>	3-6
3.2.5.	<i>Anti-seismic Design Requirements</i>	3-7
3.2.6.	<i>Fireproof Design Requirements</i>	3-7
3.2.7.	<i>Precautions for Equipment Handling</i>	3-7
3.3.	INSTALLATION TOOLS AND MATERIALS	3-7
3.4.	PRODUCT CONFIGURATION LIST	3-8
3.4.1.	<i>Basic Configuration of the Product</i>	3-8
3.4.2.	<i>Optional Components</i>	3-8
3.5.	UNPACKING FOR ACCEPTANCE	3-9
3.5.1.	<i>Preparation</i>	3-9
3.5.2.	<i>Unpacking</i>	3-10
3.5.3.	<i>Goods Acceptance</i>	3-14
4.	Equipment Installation and Connection	4-1
4.1.	CABINET INSTALLATION	4-1
4.1.1.	<i>Installation on the Cement Floor</i>	4-2
4.1.2.	<i>Installation on the Antistatic Floor</i>	4-8
4.1.3.	<i>Installing the Cabinet Guide Rails</i>	4-14
4.2.	INSTALLING THE EQUIPMENT	4-15
4.2.1.	<i>Installing the 10U Chassis</i>	4-15
4.2.2.	<i>Installing the Fan Module</i>	4-16
4.2.3.	<i>Installing the Air Deflector Frame</i>	4-19
4.3.	CONNECTING THE POWER AND GROUNDING CABLES	4-21
4.3.1.	<i>Connecting the Power Cables of the Equipment</i>	4-21
4.3.2.	<i>Connecting the Power Cable of the Fans</i>	4-22
4.3.3.	<i>Connecting the Grounding Cables</i>	4-22
4.3.4.	<i>Equipment Power Supply Test</i>	4-23
4.4.	INSTALLING THE SERVICE PROCESSOR UNIT BOARD (SMUB)	4-23
4.4.1.	<i>Installing the Uplink Interface Modules</i>	4-23
4.4.2.	<i>Installing the RTU</i>	4-25

4.4.3.	<i>Installing the SMUB</i>		4-27
4.4.4.	<i>Connecting the Ethernet Interfaces of SMUB</i>		4-28
4.4.5.	<i>Connecting the Optical Interfaces of SMUB</i>		4-30
4.5.	INSTALLING THE SUBSCRIBER SERVICE CARDS		4-31
4.6.	INSTALLING THE DUMMY PANELS		4-31
4.7.	CONNECTING THE SUBSCRIBER CABLES		4-32
4.8.	CONNECTING THE CONSOLE CABLE		4-37
5.	Suggestions to Ethernet Cabling	5-1	
5.1.	REQUIREMENTS FOR CABLE TYPES		5-1
5.2.	REQUIREMENTS FOR CABLING LENGTH		5-1
5.3.	SPACING REQUIREMENTS FOR INDOOR CABLING		5-1
5.4.	SEVERAL FORBIDDEN OVERHEAD CABLING METHODS		5-3
5.5.	OTHER REQUIREMENTS FOR OUTDOOR CABLING		5-4
5.6.	INSTALLING EXTERNAL LIGHTNING ARRESTER		5-4
6.	System Configuration and Management	6-1	
6.1.	EQUIPMENT POWER-ON		6-1
6.2.	SETTING UP THE CONFIGURATION ENVIRONMENT		6-1
6.2.1.	<i>Local Configuration via the Console Interface</i>		6-1
6.2.2.	<i>Remote Configuration via Telnet</i>		6-3
6.3.	COMMAND LINE SYSTEM		6-4
6.3.1.	<i>Command Mode</i>		6-4
6.3.2.	<i>Common Commands</i>		6-4
6.3.3.	<i>Online Help of Command Line</i>		6-5
6.3.4.	<i>Command Line Edit Feature</i>		6-6
6.4.	SYSTEM MANAGEMENT		6-6
6.4.1.	<i>Storage Media and File Type</i>		6-6
6.4.2.	<i>Program File Management</i>		6-7
6.4.3.	<i>Configuration File Management</i>		6-7
Part II		8	
7.	System Maintenance	7-1	
7.1.	SYSTEM UPGRADE		7-1
7.1.1.	<i>Storage Media and File Type</i>		7-1
7.1.2.	<i>Sequence of System Upgrade</i>		7-1
7.1.3.	<i>Upgrading the System File</i>		7-1
7.1.4.	<i>Upgrading the Master System Control Board</i>		7-10
7.1.5.	<i>Upgrading the Standby System Control Board</i>		7-12
7.2.	MANAGING THE CONFIGURATION FILE		7-12
7.2.1.	<i>Type and Format of Configuration File</i>		7-12

7.2.2.	<i>Backing up the Configuration File</i>		7-13
7.2.3.	<i>Loading the Configuration File</i>		7-14
7.2.4.	<i>Erasing the Configuration File</i>		7-14
7.3.	QUERYING THE MAINTENANCE INFORMATION		7-14
7.3.1.	<i>Querying the Current Software Version</i>		7-14
7.3.2.	<i>Viewing the Current Configuration</i>		7-15
7.3.3.	<i>Querying the Port Status</i>		7-15
7.3.4.	<i>Querying the VLAN Status</i>		7-16
7.3.5.	<i>Viewing FIB Table</i>		7-17
7.3.6.	<i>Viewing the ARP Table</i>		7-17
7.3.7.	<i>Viewing the Route Information</i>		7-18
7.3.8.	<i>Querying the System Running Time</i>		7-18
7.4.	HANDLING PASSWORD LOSS		7-18
8.	Port Maintenance	8-1	
8.1.	CHECKING THE OPTICAL INTERFACE		8-1
8.2.	CHECKING THE STATUS OF THE USER PORT		8-2
8.2.1.	<i>Querying the ADSL Port Status</i>		8-2
8.2.2.	<i>Querying the VDSL Port Status</i>		8-5
9.	Card Maintenance	9-1	
9.1.	MAINTENANCE FOR SYSTEM CONTROL BOARD		9-1
9.1.1.	<i>Check</i>		9-1
9.1.2.	<i>Hot Plugging</i>		9-2
9.1.3.	<i>Master/Standby Switchover</i>		9-2
9.1.4.	<i>Reset</i>		9-4
9.1.5.	<i>Replacing System Control Board</i>		9-4
9.2.	MAINTENANCE FOR SERVICE BOARD		9-6
9.2.1.	<i>Check</i>		9-6
9.2.2.	<i>Hot Plugging</i>		9-7
9.2.3.	<i>Reset</i>		9-8
9.2.4.	<i>Replacing Service Board</i>		9-8
10.	Power Distribution System Maintenance	1	
10.1.	CHECKING AIR-BREAK SWITCH		1
11.	Line Provisioning & Maintenance	11-1	
11.1.	MAINTENANCE FOR AIR FILTER		11-1
11.1.1.	<i>Checking Air Filter</i>		11-1
11.1.2.	<i>Cleaning and Replacing Air Filter</i>		11-1
11.2.	MAINTENANCE FOR FAN SHELF		11-2
11.2.1.	<i>Checking Fan Shelf</i>		11-2

11.2.2.	<i>Replacing Fan Shelf</i>		11-2
12.	Line Commissioning and Maintenance	12-1	
12.1.	COMMISSIONING AND MAINTENANCE OF ADSL SUBSCRIBER LINE		12-1
12.1.1.	<i>ADSL Technical Parameters</i>		12-1
12.1.2.	<i>ADSL Line Commissioning</i>		12-5
12.1.3.	<i>ADSL Line Maintenance</i>		12-12
12.2.	COMMISSIONING AND MAINTENANCE OF THE VDSL SUBSCRIBER LINE		12-17
12.2.1.	<i>VDSL Technical Parameters</i>		12-17
12.2.2.	<i>VDSL Line Commissioning</i>		12-19
12.2.3.	<i>VDSL Line Maintenance</i>		12-22
13.	Fault Analysis and Solution	13-1	
13.1.	PROBLEM LOCATION & INFORMATION COLLECTION		13-1
13.1.1.	<i>General Check</i>		13-1
13.1.2.	<i>Layer-2 Check</i>		13-1
13.1.3.	<i>Layer-3 Check</i>		13-2
13.1.4.	<i>Service Check</i>		13-2
13.2.	UNSTABLE SERVICE DUE TO WRONG MAKING OF NETWORK CABLES		13-2
13.2.1.	<i>Common Causes</i>		13-2
13.2.2.	<i>Processing Procedure</i>		13-3
13.2.3.	<i>Typical Cases</i>		13-3
14.	Operation Instructions for the Auxiliary Devices	14-1	
14.1.	USE OF AC/DC CONVERTER		14-1
Appendix		14-1	

LIST OF FIGURES

Figure 1-1	Triple Play services in Next Generation Networks.....	1-1
Figure 2-1	General chassis of 3P@C 4450E	2-1
Figure 2-2	Rear view of the general chassis of 3P@C 4450E	2-2
Figure 2-3	Front view of the 10U chassis	2-3
Figure 2-4	Slots for the SMUB and service boards	2-3
Figure 2-5	Front view of the fan module	2-4
Figure 2-6	Outside view of the radiator fans.....	2-4
Figure 2-7	Sectional view of the air deflector frame	2-4
Figure 2-8	Heat dissipation of a single system.....	2-5
Figure 2-9	Air ducts inside the cabinet	2-5
Figure 2-10	Full configuration of 3P@C 4450E.....	2-6
Figure 2-11	Slots of the SMUB	2-7
Figure 2-12	Front view of the SMUB	2-8

Figure 2-13 Slots of the VDUB	2-10
Figure 2-14 Front view of the VDSL	2-10
Figure 2-15 Slots of the ADUB	2-12
Figure 2-16 Front view of the ADUB.....	2-12
Figure 2-17 Slots of the ADUC	2-13
Figure 2-18 Front view of the ADUC.....	2-13
Figure 2-19 Connection relations.....	2-14
Figure 2-20 Front view of the DS-1GLX module	2-16
Figure 2-21 Front view of the DS-1GSX module	2-17
Figure 2-22 Front view of the DS-2FMM module	2-18
Figure 2-23 Front view of the DS-2FSM module	2-20
Figure 2-24 Front view of the DS-4TXB module.....	2-21
Figure 2-25 Front view of the DS-4ITX module.....	2-22
Figure 3-1 Recommended power sockets.....	3-3
Figure 3-2 Appearance of the packing box.....	3-10
Figure 3-3 Packing structure of the equipment inside the packing box.....	3-11
Figure 3-4 Appearance of the cabinet packing box.....	3-12
Figure 3-5 Draw out the packing box backward from the reverse direction	3-13
Figure 4-1 Cabinet installation flow chart	4-1
Figure 4-2 Equipment installation space	4-2
Figure 4-3 Flow of cabinet installation on the cement floor	4-3
Figure 4-4 Mounting hole positions for a single cabinet	4-4
Figure 4-5 Mounting hole positions for two cabinets	4-4
Figure 4-6 Installation sequence of the pressure plate assembly	4-6
Figure 4-7 Completion of the installation of a single cabinet.....	4-6
Figure 4-8 The connecting boards before combining two cabinets side by side.....	4-7
Figure 4-9 The connecting boards after combining two cabinets side by side.....	4-7
Figure 4-10 Effect after the installation of two combined cabinets	4-7
Figure 4-11 Appearance of the A600 series support.....	4-8
Figure 4-12 Completion of the installation of a single cabinet.....	4-9
Figure 4-13 Flow of the cabinet installation on the antistatic floor.....	4-9
Figure 4-14 Cabinet marking template	4-10
Figure 4-15 Connection positions of the mounting holes for the support and the antistatic floor	4-11
Figure 4-16 Assembly chart of the pressure plate assembly	4-12
Figure 4-17 Positions of the bolts to be fastened	4-13
Figure 4-18 Completion of the installation of two combined cabinets	4-14
Figure 4-19 Guide rail	4-15
Figure 4-20 Front view of the guide rails installed	4-15

Figure 4-21 Fixing the hangers onto the 10U chassis	4-16
Figure 4-22 Insert the 10U chassis into the rack and fix it	4-16
Figure 4-23 Install the fan supports	4-17
Figure 4-24 Install the fan module	4-17
Figure 4-25 Operate the puller adapter	4-18
Figure 4-26 Install the air deflector frame.....	4-19
Figure 4-27 Completion of the installation of a single general chassis	4-20
Figure 4-28 Installation of the -48V DC power cables	4-21
Figure 4-29 Power cable connection of the fans	4-22
Figure 4-30 Panel view of the SUMB.....	4-23
Figure 4-31 Insert the pins of the uplink interface module into the socket of the SMUB.....	4-24
Figure 4-32 Fix the uplink interface module with screws.....	4-25
Figure 4-33 Installation position of the RTU	4-25
Figure 4-34 Insert the pins of the RTU into the socket of the SMUB	4-26
Figure 4-35 Fix the RTU with screws.....	4-26
Figure 4-36 Rear view of the RTU installed with screws and nuts	4-27
Figure 4-37 Installation of the SMUB.....	4-27
Figure 4-38 RJ-45 connector	4-28
Figure 4-39 Illustration of making a straight-through cable	4-29
Figure 4-40 Illustration of making a crossover cable	4-29
Figure 4-41 Ethernet interface connection of the SMUB	4-30
Figure 4-42 SC optical connector	4-30
Figure 4-43 Uplink optical interface connection.....	4-31
Figure 4-44 Install a dummy panel	4-32
Figure 4-45 Installation of the LU and LC subscriber cables on the backplane	4-33
Figure 4-46 Pinouts of the LU subscriber cable	4-33
Figure 4-47 Pinouts of the LC telephone line	4-34
Figure 4-48 Cable bending and binding	4-36
Figure 4-49 Single binding	4-37
Figure 4-50 Double binding	4-37
Figure 4-51 Console interface connection.....	4-38
Figure 4-52 Input the connection name and select an icon for it.....	4-38
Figure 4-53 Select the connecting serial port	4-39
Figure 4-54 Communication parameter setting	4-39
Figure 4-55 Select the terminal emulation type	4-40
Figure 5-1 Requirements for cabling length	5-1
Figure 5-2 Parallel and crossed net spacing	5-3
Figure 5-3 Direct overhead cabling between two buildings without any protection (1)	5-3

Figure 5-4 Direct overhead cabling between two buildings without any protection (2)	5-3
Figure 5-5 Direct overhead cabling between two buildings without any protection (3)	5-3
Figure 5-6 Direct overhead cabling from the outdoors of the top of a buildings to the bottom floor without any protection	5-4
Figure 5-7 Connection of the external lightning arrester	5-4
Figure 6-1 Remote management of 3P@C 4450E via Telnet.....	6-3
Figure 7-1 Connecting the console cables	7-5
Figure 7-2 hoosing the file to be sent	7-8
Figure 7-3 File transfer interface.....	7-8
Figure 7-4 Connection mode	7-9
Figure 11-1 Schematic diagram of pulled handle operation.....	11-3
Figure 11-2 Installation of fan support	11-4
Figure 11-3 Installation of fan module	11-4
Figure 12-1 Frequency range of ADSL.....	12-1
Figure 12-2 The pass-band characteristics of the ADSL voice splitter.....	12-2
Figure 12-3 ADSL distribution.....	12-6
Figure 12-4 Connection of splitters.....	12-9
Figure 12-5 VDSL frequency range	12-17
Figure 12-6 VDSL distribution.....	12-19
Figure 12-7 Connection of splitters.....	12-21
Figure 12-8 Networking diagram	12-24

LIST OF TABLES

Table 1-1 Boards, cards and uplink interface modules provided by 3P@C 4450E	1-2
Table 1-2 Name, quantity and type of the interfaces supported by 3P@C 4450E.....	1-3
Table 1-3 Performance indexes of the 3P@C 4400 ^E	1-3
Table 2-1 General chassis composition of 3P@C 4450E	2-1
Table 2-2 Interface features of the SMUB.....	2-8
Table 2-3 Type of uplink interface modules.....	2-8
Table 2-4 Status definitions of the LED indicators on the SMUB	2-9
Table 2-5 Status definitions of the LED indicators on the front panel of VDUB	2-11
Table 2-6 Status definitions of the LED indicators on the front panel of ADUB	2-12
Table 2-7 Status definitions of the LED indicators on the front panel of ADUC	2-14
Table 2-8 Types of uplink interface modules.....	2-15
Table 2-9 Status definitions of the LINK and ACT LEDs on the DS-1GLX module	2-16
Table 2-10 Gigabit long-wave optical interface features of the DS-1GLX module.....	2-16
Table 2-11 Status definitions of the LINK and ACT LEDs on the DS-1GSX module	2-17
Table 2-12 Interface features of the DS-1GSX module.....	2-18

Table 2-13 Status definitions of the LINK and ACT LEDs on the DS-2FMM module	2-19
Table 2-14 Interface features of the DS-2FMM module	2-19
Table 2-15 Status definitions of the LINK and ACT LEDs on the DS-2FSM module	2-20
Table 2-16 Interface features of the DS-2FSM module	2-20
Table 2-17 Status definitions of the LINK and ACT LEDs on the DS-4TXB module	2-21
Table 2-18 Interface features of the DS-4TXB module	2-21
Table 2-19 Status definitions of the LINK and ACT LEDs on the DS-4ITX module	2-22
Table 2-20 Interface features of the DS-4ITX module	2-23
Table 2-21 Structure of the RTU	2-23
Table 4-1 Pinouts of the RJ-45 MDI interface	4-28
Table 4-2 Pinouts of the RJ-45 MDIX interface	4-28
Table 4-3 Pinouts of the LU subscriber cable	4-33
Table 4-4 Pinouts of the LC telephone line	4-35
Table 5-1 Requirements of spacing between Ethernet cables and cables of other electric devices	5-2
Table 5-2 Requirements of spacing between the Ethernet cables on the wall and other pipelines	5-2
Table 6-1 Description of the read-only mode and the configuration mode	6-4
Table 6-2 Commands in the read-only mode	6-4
Table 6-3 Common commands in the configuration mode	6-5
Table 6-4 Line edit commands in the command line	6-6
Table 6-5 Correspondence between file types and command line parameters of 3P@C 4450E	6-6
Table 7-1 Bootrom command	7-3
Table 7-2 Upgrade submenu in the network port	7-3
Table 7-3 Relevant parameters downloaded by the network port of system control board	7-4
Table 9-1 Description of LED status of the system control board SMUB	9-1
Table 9-2 Description of the indicator of the VDUB service board	9-6
Table 12-1 ADSL parameter setting table	12-3
Table 12-2 ADSL subscriber line length attenuation table	12-4
Table 12-3 ADSL line attenuation per kilometer within different frequency bands	12-4
Table 12-4 ADSL line connection parameters	12-6
Table 12-5 DC loop resistance for subscriber lines with different core diameters per kilometer	12-8
Table 12-6 Line test reference table	12-8
Table 12-7 ADSL service line reference table	12-10
Table 12-8 Broadband service user information record table	12-11
Table 12-9 ADSL setting parameters and connection parameter record table	12-11
Table 12-10 The minimum SNR value for the rates (for reference)	12-18
Table 12-11 DC resistance reference value of common lines	12-20
Table 12-12 VDSL setting parameters and connection parameter record table	12-22

USE GUIDE TO THIS MANUAL

Target Readers

This manual is intended for system administrators responsible for the installation and maintenance of the 3P@C 4450E IP-DSLAM ("3P@C 4450E"). Readers should have the following knowledge:

- Local Area Networks (LANs)
- Ethernet Concepts
- Ethernet Switching and Bridging Concepts
- Routing Concepts
- Simple Network Management Protocol (SNMP)

Contents

This manual describes the installation and maintenance of 3P@C 4450E, including its features, components, component functions as well as equipment connections and maintenance.

It briefly describes some software configuration information. For a detailed description of the commands and configuration operations, please refer to the *3P@C 4450E IP-DSLAM Software Configuration Manual* and the *3P@C 4450E IP-DSLAM Command Reference*.

The 3P@C 4450E IP DSLAM User Manual consists of three parts:

Part I Hardware Installation

It introduces the structure, installation, connection and basic configuration of the 3P@C 4450E , specifically including the following contents:

Chapter Title Contents

Chapter 1
Product Overview
Introduces the functions, features and system components of 3P@C 4450E

Chapter 2
Product Structure
Describes the integrated equipment structure of 3P@C 4450E as well as the components and functions of its parts or modules

Chapter 3
Installation Preparation
Describes the installation environment and safety requirements, installation tools, materials, product configuration and unpacking inspection of 3P@C 4450E

Chapter 4
Equipment Installation and Connection
Describes the installation and cable connection of cabinets, chassis and modules of 3P@C 4450E

Chapter 5
Ethernet Cabling Suggestions

3P@C Installation Manual

Gives suggestions on the FE interface cabling in practical engineering

Chapter 6

System Configuration and Management

Introduces the setup of the configuration environment, the command line system and the management mode of the related programs and files in the system

Part II Maintenance

It introduces the maintenance methods and related knowledge of the 3P@C 4450E , specifically including the following contents:

Chapter Title Contents

Chapter 7

System Maintenance

Describes system upgrade, configuration file management, common maintenance information view and handling of password loss

Chapter 8

Port Maintenance

Describes optical interface detection and subscriber port status check

Chapter 9

Card Maintenance

Describes the maintenance of SMUB and service boards such as VDUB/ADUB/ADUC

Chapter 10

Power Distribution System Maintenance

Describes the check and handling of air switches

Chapter 11

Accessories Maintenance

Describes the maintenance of dust filters and fan frames

Chapter 12

Line Provisioning & Maintenance

Describes the provisioning and maintenance of ADSL and VDSL lines

Chapter 13

Fault Analysis and Solution

Describes the fault location and information collection methods and the handling in the case of service interruption from time to time due to incorrect making of the network cables

Chapter 14

Operation Instructions for the Auxiliary Devices

Describes the usage of the HD4825 DC/AC converter

Appendix Common Troubleshooting & Relevant Knowledge

It introduces the common troubleshooting and related knowledge of the 3P@C 4450E, specifically including the following contents:

Appendix A

Diagnosis of Common Faults

Lists some common faults of 3P@C 4450E and the possible causes and solutions

Appendix B

Glossary

Explains some terminologies involved in this manual

Appendix C

Fiber-related Knowledge

Gives the related knowledge about optical fibers

Conventions

Conventions for icons are listed as follows:

Icon

Description



Warning

Notifies users that improper operation may cause damage to human body or equipment, service disruption or data loss during the process of installation and service configuration.



Note

This icon alerts users to some precautions.



prompt

This icon provides some text-related information and some guidance for users, and helps users understand the text better.

Technical Support

SAGEM establishes a complete hierarchical service system consisting of 3 levels, namely, the headquarter, area and local technical support centers. It provides all-weather and full-time telephone hotline services. Any time when users have problems on our product and network operation, feel free to contact us by local service support hotlines. Visit www.sagem.com to find out the local service support hotlines, to see the latest products and to download needed technical documents.

PART I

Hardware Installation

CHAPTER 1

1. Overview of the 3P@C 4450E IP-DSLAM

This chapter describes the typical networking models, features and performance indexes of the 3P@C 4400E.

1.1. System Overview

As the heart of Next Generation network architecture, SAGEM 3P@C 4450E and 4048E are high-performance IP-DSLAM platforms that enable to deliver a wide variety of services such as broadband internet, voice over packet, LAN to LAN connections, video multicast streaming, leased lines and VPN, on any subscriber line. Thanks to their flexible, modular and scalable design, SAGEM 3P@C systems can provide all services simply by the composition of relevant units in the same carrier-class platform.

NG-DSLAM

SAGEM 3P@C supports any combinations of ADSL, ADSL2/2+ or VDSL user interfaces in several types of high-density configurations : mini-shelf and large shelves.

Thanks to its internal architecture, the SAGEM 3P@C is able to concentrate user streams and switch them to several network interfaces, managing traffic parameters in order to guarantee QoS requirements. Subtending interfaces can be used to create star and daisy-chain extensions, offering a high scalability in order to reach remote users.

A wide variety of Fast Ethernet, Giga Ethernet, Packet over SDH and even ATM uplink interfaces allows the connection to Next Generation IP and Ethernet networks. Enhanced video services can be delivered over ADSL2+ or ADSL connections, such as TV broadcast, Video on Demand and Pay Per View, using SAGEM 3P@C multicast and IGMP capabilities. Connecting to ISP network, SAGEM 3P@C can support B-RAS features such as PPP session processing, tunnelling and termination, user authentication, IP address management and dynamic routing.

Management

SAGEM IONOS NMS management platform is designed for the provisioning, monitoring and supervision of the whole SAGEM 3P@C product family. This powerful NMS allows network-wide visibility and provides user-friendly graphical features. In addition, IONOS NMS enhances operational efficiency with its powerful client/server architecture.

Scalable range

SAGEM 3P@C is a complete range of access equipment, scaling from small sized configurations to large central office nodes.

SAGEM 3P@C 4450E is dedicated to high density CO, connecting up to 448 DSL users per subrack, whereas SAGEM 3P@C 4048E is designed for small CO or remote sites connecting up to 48 ADSL users.

The micro-DSLAM is targeted to specific applications, such as Multi-Tenant Unit (MTU) and remote area. Thanks to its stackable design, up to 192 users can be connected as the need for broadband connections grows. The 3P@C 4048E can be installed as a stand alone unit connected to a switched network or as an extension of 3P@C 4450E in subtending mode.

1.2. Representative Networking Applications

SAGEM is in a unique position to assist its customers with the design and implementation of next-generation service offerings using Ethernet based broadband technology. SAGEM 3P@C solutions provide incumbent and competitive carriers with Internet access, Voice over IP (VoIP), broadcast video (IPTV), Video on Demand (VoD), Pay-Per-View, music channels and interactive television.

SAGEM 3P@C approach has shown reduced Cost of Ownership through Ethernet-based IP broadband technology. Applying this technology to a solution customized for each customer can provide them with the technological and competitive advantage needed for continued success in the broadband service market.

SAGEM 3P@C delivers an IP based broadband access solution that meets customer's current needs as well as their future needs for multi-service offerings. Our products are currently supporting all current service offerings such as residential and commercial Internet access, Internet access through other ISPs, and LAN-to-LAN connectivity.

SAGEM is able to build up Triple Play end to end solutions using F@st residential gateways and CPE, 3P@C IP-DSLAM, GigaP@C MAN Ethernet switches or Ethernet over SDH equipment, and B-RAS, Video Streamers and Voice Gateways and Softswitches.

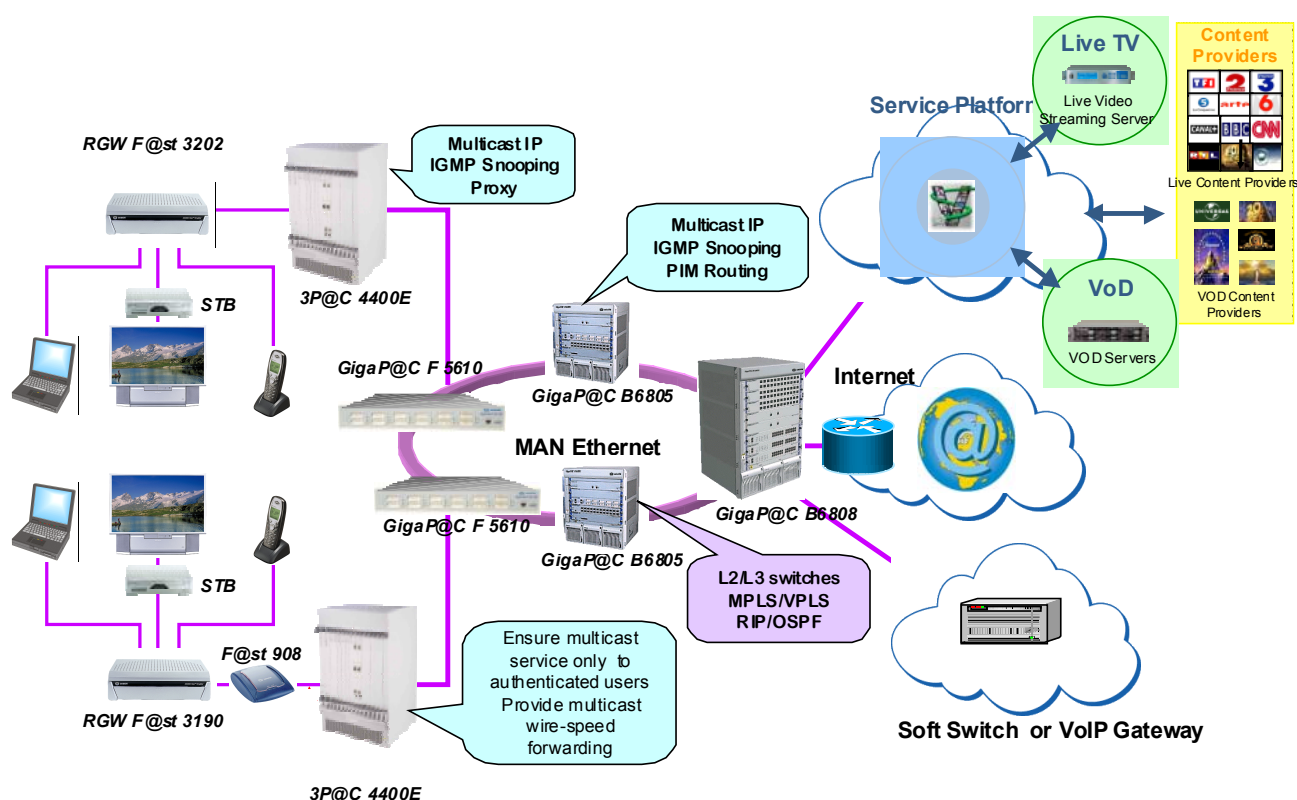

Figure 1-1 Triple Play services in Next Generation Networks

1.3. System Composition

The 3P@C 4450E is composed of the following parts:

- General chassis: It consists of a 10U chassis, a backplane, a fan module, a fan mounting support and an air deflector frame.
- Interface: Multiple uplink interfaces can be provided, including 100M electrical/optical interfaces, gigabit optical interfaces and ATM interfaces.
- Slots: Each 10U chassis provides 16 slots, where 2 are SMUB slots and 14 are service board/card slots.
- Power supply: The -48 V DC power supply is adopted. To connect to the 220 V AC power supply, it is necessary to use the primary power supply system.

3P@C 4450E is installed in the 19-inch standard cabinet with the height of 2.2 m.

Based on the high-performance ASIC, 3P@C 4450E adopts modular structure design to provide abundant uplink interface modules for your choice. See 1-1 for the specific module types. Each 3P@C 4450E consists of a 10U chassis, a fan module, an air deflector frame and a fan frame support. Up to 16 boards/cards can be installed in each 3P@C 4450E chassis. Among them, up to 2 SMUBs and 14 VDSL or ADSL service boards/cards can be installed. Each SMUB can provide 2 gigabit optical interfaces/4 100M optical interfaces/8 100M electrical interfaces/2 155M ATM interfaces. Each VDUB can provide 24 VDSL data interfaces, and the integrated equipment supports up to 336 VDSL interfaces. Each ADUB can provide 32 ADSL interfaces, and the integrated equipment supports up to 448 ADSL interfaces. See Table 1-2 for descriptions of the specific interface types. You may select the appropriate boards, cards and uplink interface modules as required.

Table 1-1 Boards, cards and uplink interface modules provided by 3P@C 4450E

Module model	Name of the card/uplink interface module
SMUB	Service processor unit board
VDUB	VDSL service board
ADUB, ADUC	ADSL unit board/card
RTU	Route Transfer Unit
DS-1GLX	1-port gigabit long-wave single-mode interface board
DS-1GSX	1-port gigabit short-wave multi-mode interface board
DS-4TXB	4-port 100M interface board
DS-4ITX	Value-added service card
DS-2FMM	2-port 100M multi-mode interface board
DS-2FSM	2-port 100M single-mode interface board
DS-A155SM	1-port 155M long-wave single-mode ATM interface board
DS-A155MM	1-port 155M short-wave multi-mode ATM interface board

Table 1-2 Name, quantity and type of the interfaces supported by 3P@C 4450E

Interface name	Quantity	Interface type	Description
Gigabit optical interface (1000Base-SX/LX interface)	2 × 2	SC	Uplink interface
100M optical interface (100Base-FX interface)	4 × 2	SC	Uplink interface
100M electrical interface (10/100Base-TX interface)	(8 + 1) × 2	RJ-45	Uplink interface
ATM interface (155M single-/multi-mode ATM interface)	2 × 2	SC	Uplink interface
Console interface	1 × 2	RJ-45	Console interface
VDSL interface	24 × 14	European connector	Subscriber interfaces
ADSL interface	32 × 14	European connector	Subscriber interfaces



prompt

For the detailed description of 3P@C 4450E structure, please refer to Chapter 2.

1.4. Hardware Features

Table 1-3 lists the detailed performance indexes of the 3P@C 4450E.

Table 1-3 Performance indexes of the 3P@C 4400^E

Physical performance	3P@C 4450E	
Dimensions of the 10U chassis (Height × Width × Depth)	441.7 mm × 426.5 mm × 389.2 mm	
Dimensions of the fan module (Height × Width × Depth)	44 mm × 434.6 mm × 360.1 mm	
Dimensions of the air deflector frame (Height × Width × Depth)	86.1 mm × 434.6 mm × 371.5 mm	
Weight	17 kg when empty (containing a 10U chassis, a backplane, a fan module, a fan mounting support and an air deflector frame)	
	41 kg when fully populated (containing a 10U chassis, a backplane, a fan module, a fan mounting support, an air deflector frame and 16 boards)	
Working environment	Temperature	-5 °C ~ 50 °C
	Humidity	5% ~ 95%, non-condensing
Power supply	DC: -40.5V ~ -57V	
Power consumption	≤ 1,200 W (1,200 W in full configuration mode)	

Physical performance		3P@C 4450E
Port configuration	Uplink ports	100M electrical and optical interfaces, gigabit optical interfaces and ATM interfaces. All optical interfaces support single-mode and multi-mode interface types, and the 100M optical interfaces support the Trunk function
	Service ports	VDSL and ADSL ports
Slot		16, among which, 2 SMUB slots and 14 service board/card slots
Hot plug		Supported
Error tolerance design	Hot backup	Redundancy hot backup for core parts
	CPU detection	CPU detection
Negotiation function		Full-duplex auto-negotiation
Basic performance	Packet transfer rate (L2/L3)	Wire speed
	Forwarding mode	Store-and-forwarding
Status indication	Port status	Communication status and LINK status
	Universal status	Power status, system status & hot-swap display
Max. cable length	10/100Base-TX	100 meters Categories-3/4/5 shielded/unshielded twisted pairs
	100Base-FX	62.5/125µm multi-mode fiber (max. 2km), 9µm single-mode fiber (max. 15km)
	1000Base-SX	62.5/125 µm multi-mode fiber (max. 275m), 50/125 µm multi-mode fiber (max. 550m)
	1000Base-LX	9µm single-mode fiber (max.10km)
Electromagnetic compatibility		EMS feature: Complying with the standards of EN 55024 , ETSI EN 300 386, CISPR 24, GB/T 17626, GB/T 17618 and IEC 61000-4
Security specifications		Complying with the standards of EN 60950, UL 60950, CAN/CSA-C22.2 NO. 60950, GB 4943, IEC 60950, and AS/NZS 60950
Interface type	100Base-FX interface	SC
	1000Base-SX interface	SC
	1000Base-LX interface	SC
	DS-A155MM (155M multi-mode ATM) interface	SC
	DS-A155SM (155M single-mode ATM) interface	SC
	Console interface	RJ-45
	10/100Base-TX interface	RJ-45



CHAPTER 2

2. 3P@C 4450E Hardware Structure

This chapter describes hardware structure of the 3P@C 4450E, including the whole-equipment configurations and the description of each service module.

2.1. Shelf Configuration

2.1.1. Structure of the General Chassis

The general chassis of 3P@C 4450E is called 3P@C 4450E-IPDSLAM-10U general chassis kit. It contains a 10U chassis, a backplane, a fan module, a fan mounting support and an air deflector frame. Its outside view is shown in Figure 2-1.

Figure 2-1 General chassis of 3P@C 4450E

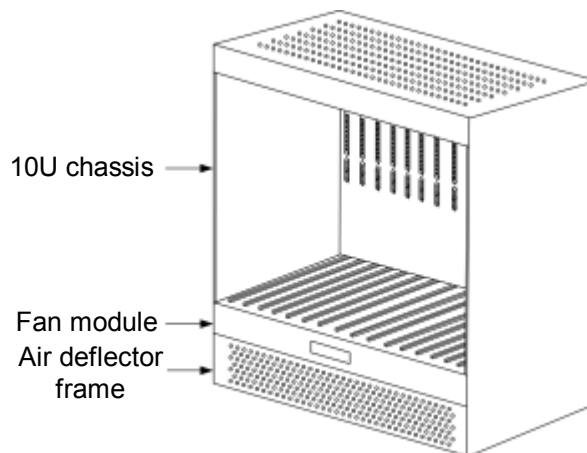

The general chassis composition of 3P@C 4450E is described in Table 2-1:

Table 2-1 General chassis composition of 3P@C 4450E

Name	Height	Composition	Application
10U chassis	10U	Slots 0 ~ 1	For SMUB
		Slots 2 ~ 15	For ADUB, ADUC or VDUB
Fan module	1U	6 fans inside	For system cooling
Air deflector frame	2U	Slant spacer inside	Air ducts (inlet from the front and outlet from the rear)

3P@C 4450E provides the uplink interface and the Console port on the SMUB. The rest subscriber line outlets are set on the backplane, that is, the rear leading-out mode is adopted. Therefore, all the subscriber line interfaces and power supply interfaces are provided on the rear of 3P@C 4450E, as shown in Figure 2-2:

Figure 2-2 Rear view of the general chassis of 3P@C 4450E

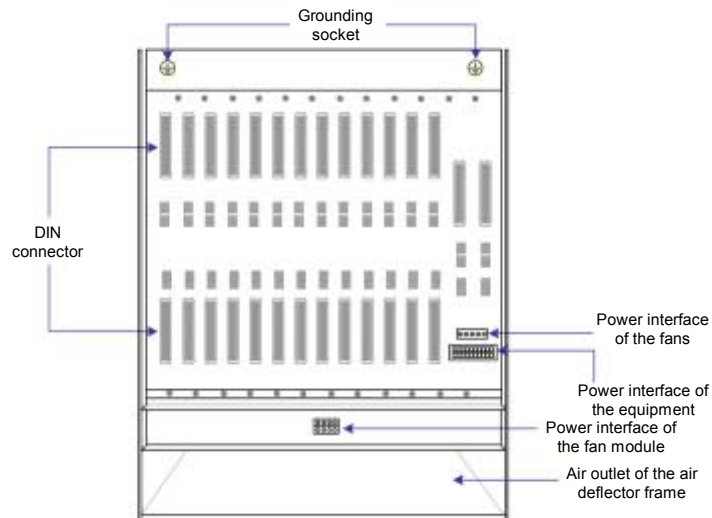

Viewed from the rear, the general chassis of 3P@C 4450E consists of the following parts:

- DIN connector: Subscriber line interface
- Equipment power supply interface: -48 V DC power supply interface
- Fan power supply interface: Connects with the fan module power socket to supply power to the fan
- Fan module power socket: Connects with the fan power supply interface to supply power to the fan
- Grounding socket: Equipment grounding
- Outlet of the air deflector frame: Hot air outlet of the switch below when multiple sets of equipment are working

The DIN connectors are used for the subscriber line interfaces in two rows (upper and lower). Each DSL service board needs 2 groups of subscriber lines. One group is the LU line that corresponds to the connector in the upper row and is connected to the subscriber line, and the other group is the LC line that corresponds to the connector in the lower row and is connected to the PSTN switch. The slots correspond to the types of the service boards inserted in the chassis front to support subscribers of different quantities. For the definition and connection method of subscriber lines, refer to the contents in Section 4.7.

- For ADUB/ADUC, each slot supports 32 subscribers.
- For VDUB, each slot supports 24 subscribers.

The 3P@C 4450E rear also provides an equipment power supply interface, a fan power supply interface and a fan module power supply socket.



prompt

Here the -48 V DC power supply is adopted for 3P@C 4450E.

In addition, two grounding sockets marked with  are provided on the upper part of the rear panel for equipment grounding.

2.1.2. 10U Chassis

The 10U chassis is adopted for 3P@C 4450E. Altogether 2 SMUBs and 14 ADSL/VDSL service boards can be installed at the same time, as shown in the following figure:

Figure 2-3 Front view of the 10U chassis

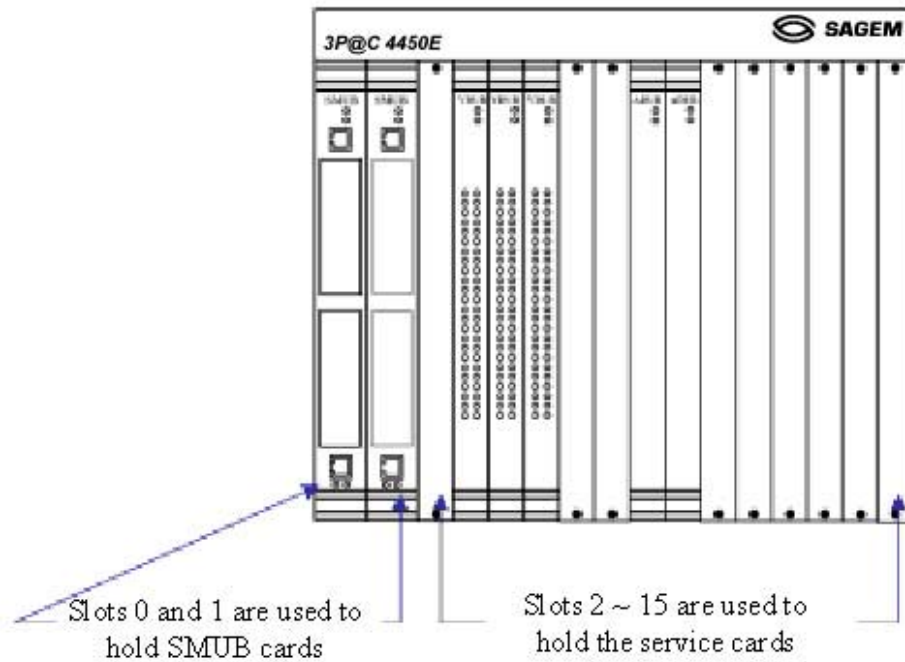

Each 10U chassis provides 16 slots which are numbered 0 ~ 15 from left to right. The former 2 slots (slots 0 ~ 1) with a width of 1.4 inch each are used to insert the SMUBs. SMUBs can be inserted in both slots at the same time, or only one SMUB is inserted either in slot 0 or in slot 1. The latter 14 slots (slots 2 ~ 15) with a width of 1 inch and a depth of 340 mm each are used to insert VDUB or ADUB/ADUC. Descriptions of the slots for the SMUB and the service boards are shown in Figure 2-4.

Figure 2-4 Slots for the SMUB and service boards

0	1	2	3	4	5	6	7	8	9	10	11	12	13	14	15
S	S	A	A	A	A	A	A	A	V	V	V	V	V	V	V
M	M	D	D	D	D	D	D	D	D	D	D	D	D	D	D
U	U	U	U	U	U	U	U	U	U	U	U	U	U	U	U
B	B	B	B	B	B	B	B	C	B	B	B	B	B	B	B



prompt

1. The service board slots support the interchange of VDSL and ADSL service boards.
2. Please install dummy panels in the slots not inserted with any boards.

2.1.3. Fan Module

In the lower part of the 10U chassis is a 1U fan module, as shown in the following figure:

Figure 2-5 Front view of the fan module

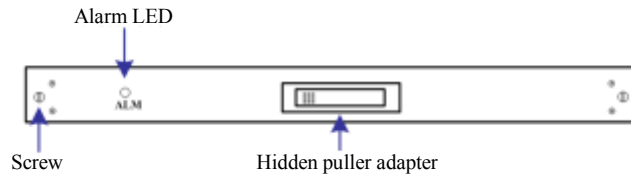

Viewed from the front, the fan module consists of the following parts:

- Screw: Used to fix the fan module.
- Alarm indicator: Used for giving out failure alarm of the fan module
- Hidden puller adapter: Usually closed. When removing the fan module, it can be used to pull out the fan module. For the specific operations, refer to the related contents in Section 4.2.2.

Each fan module provides 6 radiator fans, as shown in Figure 2-6:

Figure 2-6 Outside view of the radiator fans



2.1.4. Air Deflector Frame

Below the fan module is a 2U air deflector frame with the front inlet and rear outlet design and isolated in the middle by a spacer. The sectional view of the air deflector frame is shown in the following figure:

Figure 2-7 Sectional view of the air deflector frame

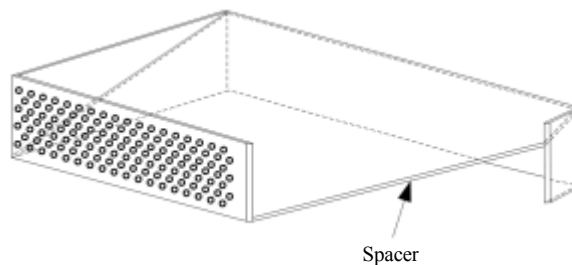

prompt

When the switch is operating, the cold air is drawn in above the spacer. If multiple switches are operating at the same time, the hot air coming out from the lower switch are exhausted below the spacer via the rear of the air deflector frame.

To satisfy the requirement for long-term equipment operating temperature, the general chassis design of 3P@C 4450E fully considers the system heat dissipation. When a single device is operating, the heat dissipation of the system is shown in Figure 2-8, where, the air is led in from the lower part and led out from the upper part in the chassis front. The air outlet is on the top of the switch.

Figure 2-8 Heat dissipation of a single system

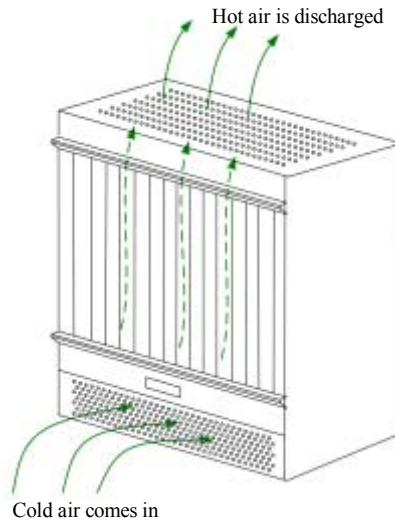

On the air deflector frame is a fan module with 6 radiator fans built in. When the fans are started, the cold air is drawn in from the inlet on the front of the air deflector frame, then goes upward in the cabinet. It passes by the switch, and takes away the heat of the switch, and finally goes out from the top of the switch.

When multiple switches operate at the same time, the hot air in the lower switch are let out from the top of the switch, and exhausted via the rear outlet of the air deflector frame above it. The following figure shows the air ducts in the cabinet in the case that multiple switches are operating at the same time.

Figure 2-9 Air ducts inside the cabinet

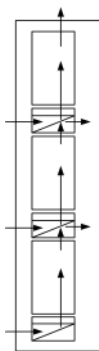

The radiator fans are used for cooling and heat dissipation to improve the temperature features of the system and ensure the normal operation of the switch. Make sure these ventilation holes are not blocked and enough space is reserved on two sides of the equipment for air circulation, ventilation and heat dissipation. Otherwise, if the components in the equipment are overheated, the system would not work normally or even the components would be damaged by overheat.

2.2. Full Configuration of the Cabinet

In the full configuration mode, 3 sets of 3P@C 4450E can be installed in a 19-inch standard cabinet with the height of 2.2 m, as shown in Figure 2-10:

Figure 2-10 Full configuration of 3P@C 4450E

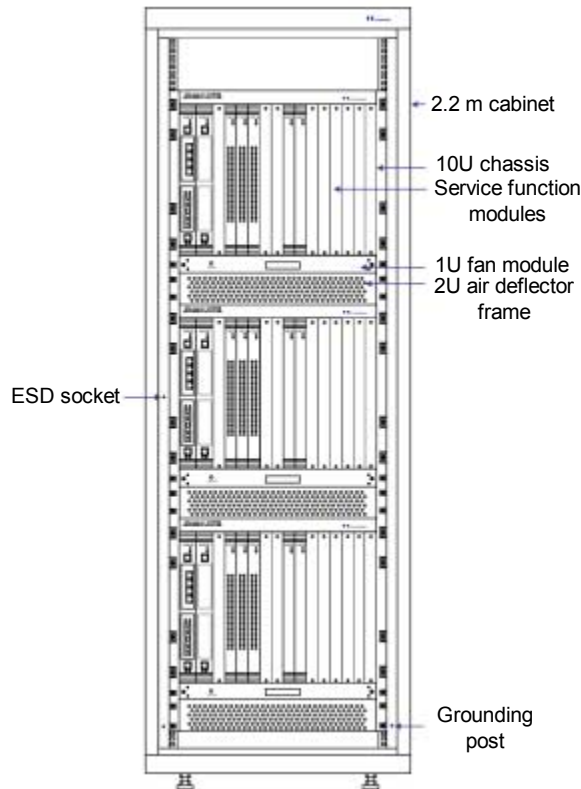

In the full configuration mode, the 3P@C 4450E system comprises 6 major parts: A standard 19-inch cabinet with the height of 2.2 m, a 10U chassis, a 1U fan module, 2U air deflector frame, service functional modules (including SMUB and ADSL/VDSL service boards) and the -48 V DC power distribution system.



prompt

1. The -48 V DC power distribution system is on the rear of the integrated equipment.
2. To connect to the 220 V AC power supply, it is necessary to use the primary power supply system.

2.3. SMUB and Service Boards

2.3.1. Service Processor Unit Board (SMUB)

1.1.1.1 Structure of the SMUB

As the control center of 3P@C 4450E, the SMUB is responsible for the data exchange and control management of the system and it provides uplink interfaces for the ADSL and VDSL subscribers to access the network.

The single-SMUB or dual-SMUB operating mode can be adopted for 3P@C 4450E. When the single-SMUB operating mode is adopted, SMUB can be inserted in slot 0 or 1 of the 10U chassis. Hot backup can be implemented in the system when the dual-SMUB operating mode is adopted, in which, two SMUBs can be inserted in slot 0 and slot 1 of the 10U chassis respectively. The SMUB in slot 0 serves as the active one, and the SMUB in slot 1 serves as the standby one, as shown in the following figure:

Figure 2-11 Slots of the SMUB

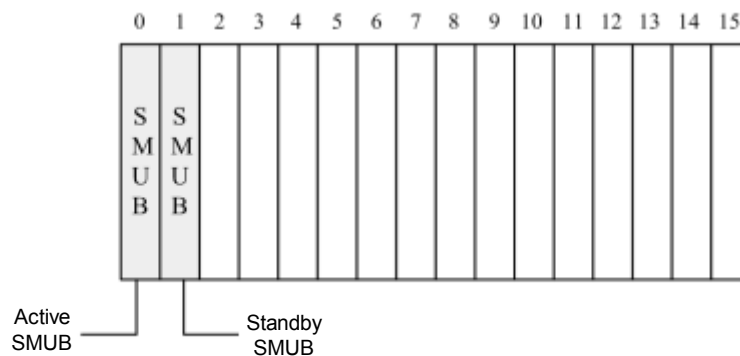

Only the active SMUB is active at one time. The equipment can be managed only via the Console interface on the active SMUB, and the Console interface on the standby SMUB is suspended.

The rear view of the SMUB is shown in Figure 2-12:

Figure 2-12 Front view of the SMUB

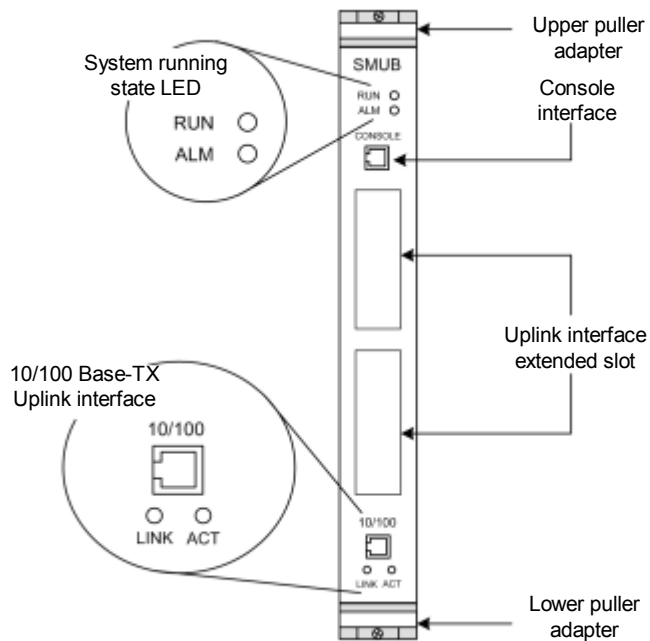

1. 1. 1. 2 Interface features of the SMUB

Table 2-2 Interface features of the SMUB

Interface name	Quantity	Interface type	Interface attributes	Description
Console interface	1	RJ-45	RS-232C	Located at the uppermost of the SMUB, the Console interface can be used to manage and configure 3P@C 4450E via the command line interface.
Ethernet uplink interface	1	RJ-45	10/100Base-TX	Located at the lowermost of the SMUB, it is used to connect the VDSL and ADSL subscribers to the IP network.

1. 1. 1. 3 Extended slots of the SMUB

The SMUB provides 2 extended slots for installing uplink interface modules. 3P@C 4450E supports the following uplink interface modules:

Table 2-3 Type of uplink interface modules

Module type	Name	Description	Interface type
DS-1GLX	1-port gigabit long-wave optical interface module	Providing 1 long-wave optical uplink interface of 1G rate	SC
DS-1GSX	1-port gigabit short-wave optical interface module	Providing 1 short-wave optical uplink interface of 1G rate	SC

Module type	Name	Description	Interface type
DS-2FSM	2-port 100M single-mode optical interface module	Providing 2 100Base-FX uplink single-mode optical interfaces	SC
DS-2FMM	2-port 100M multi-mode optical interface module	Providing 2 100Base-FX uplink multi-mode optical interfaces	SC
DS-A155SM	1-port long-wave single-mode ATM optical interface module	Providing 1 155M long-wave single-mode uplink ATM optical interface	SC
DS-A155MM	1-port short-wave multi-mode ATM optical interface module	Providing 1 155M short-wave multi-mode uplink ATM optical interface	SC
DS-4TXB	4-port 100M electrical interface module	Providing 4 10/100Base-TX uplink electrical interfaces	RJ-45
DS-4ITX	Value-added service card	Providing 4 10/100Base-TX uplink electrical interfaces	RJ-45



prompt

For the detailed description of uplink interface modules, please refer to Section 2.5.

1. 1. 1. 4 Indicators of the SMUB

The front panel of SMUB provides LEDs for indicating the system operating status and the Ethernet interface working status. The administrator can judge the system operation status according to the display of these LEDs so as to diagnose the network fault in time, reduce the operation loss and improve work efficiency. Descriptions of the LED indicators are given in Table 2-4:

Table 2-4 Status definitions of the LED indicators on the SMUB

LED	Identification	Color	Status	Description
System running status indicator	RUN	Green	Off	The system does not operate
			Flashing	The system operates normally.
	ALM	Red	Off	The system operates normally
			ON	System alarm. This LED flashes once when the equipment is started and conducts self-check. It does not indicate any alarm at this time
Ethernet interface working status indicators	LINK	Green	Solid on	The corresponding LED is solid on after a stable connection is set up at the port
			Off	The port is not connected
	ACT	Green	Flashing	Data are being received/transmitted on the port
			Off	No data are being received/transmitted on the port

2.3.2. VDSL Unit Board (VDUB)

1. 1. 1. 5 Structure of the VDUB

VDUB is the VDSL office end access service board of 3P@C 4450E. Each VDUB provides 24 VDSL subscriber interfaces. The subscriber interface is connected to the DIN connector on the backplane, thus implementing data transmission via the existing data switching line (such as telephone line) and separation of data transmission from voice transmission.

The VDUB features high security and supports IEEE 802.1Q VLAN to provide secure isolation for each subscriber. In addition, it supports the port locking function to prevent illegal subscribers from accessing the network.

VDUB adopts the -48 V power supply with an allowable voltage ranging from -36 V to -72 V. It supports hot plugging, and can identify the rack slots, thus facilitating the management and maintenance.

When used in 3P@C 4450E, the VDUBs can be inserted in slots 2 ~ 15 of the 10U chassis, as shown in the following figure:

Figure 2-13 Slots of the VDUB

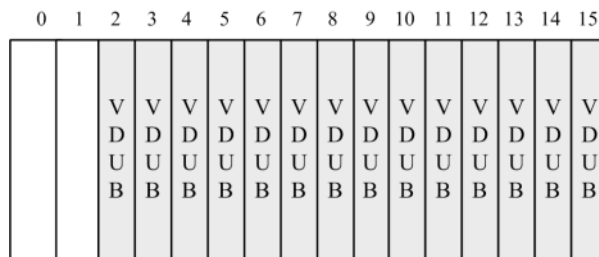

The front view of the VDUB is shown in the following figure:

Figure 2-14 Front view of the VDSL

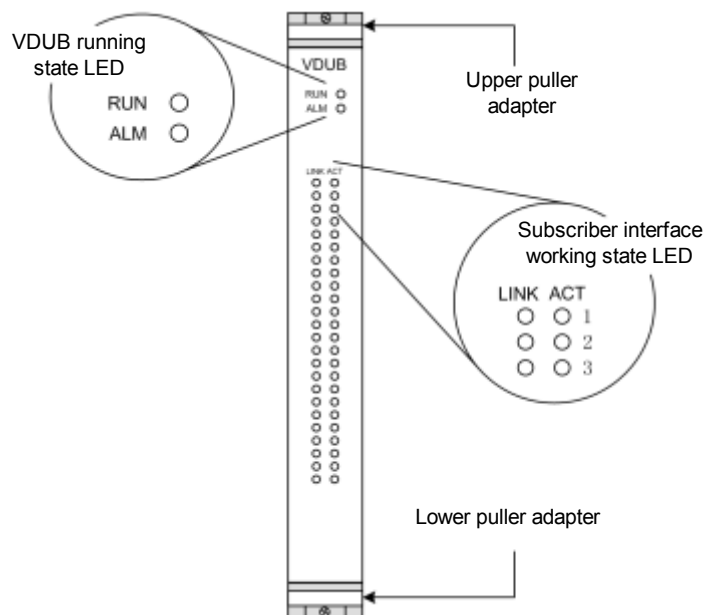

The front panel of VDUB provides two groups of LEDs, as follows:

- VDUB running status indicators RUN and ALM, which are in the upper part of the

- VDUB.
- VDSL subscriber interface working status indicators, which are in the middle of the VDUB. The VDUB provides 24 VDSL subscriber interfaces. The working status of each interface is shown by two indicators, LINK and ACT.

1. 1. 1. 6 Indicators of the VDUB

Descriptions of the LED indicators on the front panel of VDUB are given in Table 2-5:

Table 2-5 Status definitions of the LED indicators on the front panel of VDUB

LED	Identification	Color	Status	Description
VDUB running status indicator	RUN	Green	On	The system is powered on
			Off	The system is powered off or abnormal
			Flashing	The VDUB operates normally
	ALM	Red	Off	The VDUB operates normally
			ON	VDUB alarm
VDSL subscriber interface working status indicators	LINK	Green	Solid on	The corresponding LED is solid on after a stable connection is set up at the subscriber interface
			Off	The subscriber interface is not connected with any subscriber
	ACT	Green	Flashing	Data are being received/transmitted on the subscriber interface
			Off	No data are being received/transmitted on the subscriber interface

2.3.3. ADSL Unit Board (ADUB)

1. 1. 1. 7 Structure of the ADUB

The ADUB is used to provide ADSL data access services. Each ADUB provides 32 ADSL subscriber interfaces. The subscriber interface is connected to the DIN connector on the backplane, thus implementing data transmission via the existing data switching line (such as telephone line) and separation of data transmission from voice transmission.

The ADUB features high security and supports IEEE 802.1Q VLAN to provide secure isolation for each subscriber. In addition, it supports the port locking function to prevent illegal subscribers from accessing the network.

ADUB adopts the -48 V DC power supply with an allowable voltage ranging from -44 V DC to -60 V DC. It supports hot plugging, and can identify the rack slots, thus facilitating the management and maintenance.

When used in 3P@C 4450E, the ADUBs can be inserted in slots 2 ~ 15 of the 10U chassis, as shown in Figure 2-15:

Figure 2-15 Slots of the ADUB

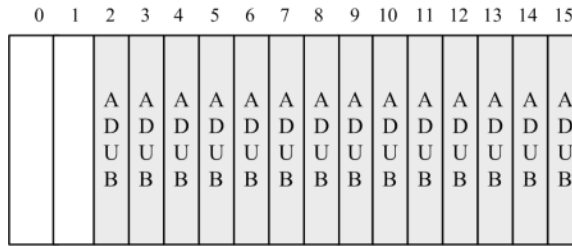

The front view of the ADUB is shown in the following figure:

Figure 2-16 Front view of the ADUB

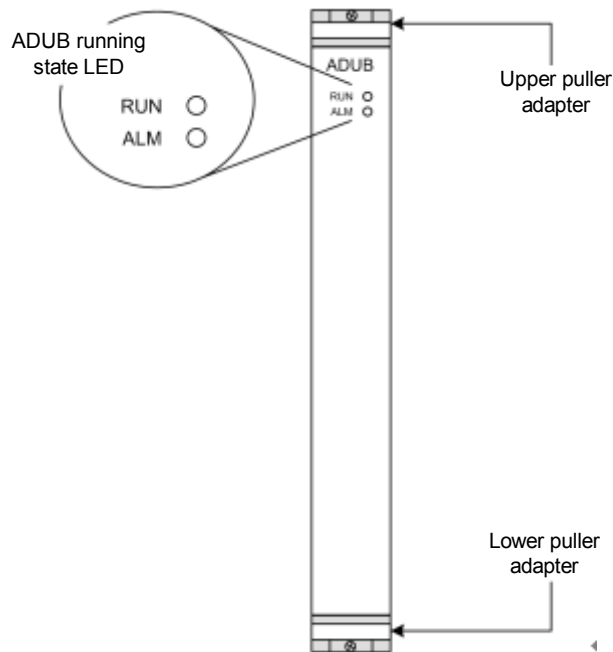

1. 1. 1. 8 Indicators of the ADUB

The front panel of ADUB provides LED indicators showing the ADUB running status. Descriptions of the LEDs are given in the following table.

Table 2-6 Status definitions of the LED indicators on the front panel of ADUB

LED	Identification	Color	Status	Description
ADUB running status indicator	RUN	Green	On	The system is powered on
			Off	The system is powered off or abnormal
			Flashing	The ADUB operates normally
	ALM	Red	Off	The ADUB operates normally
			ON	ADUB alarm

2.3.4. ADSL Unit Card (ADUC)

1. 1. 1. 9 Structure of the ADUC

In addition to the same functions and features as the ADUB, the ADUC also has a line capture relay that can be used together with the ADSL special-purpose test device to provide the wiring function.

When used in 3P@C 4450E, the ADUCs can be inserted in slots 2 ~ 15 of the 10U chassis, as shown in the following figure:

Figure 2-17 Slots of the ADUC

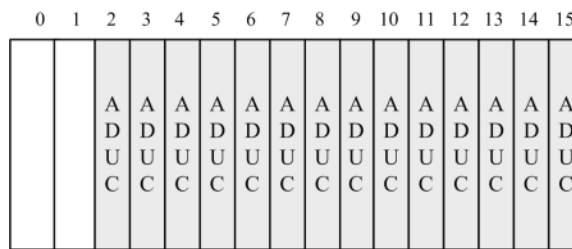

The rear view of the ADUC is shown in Figure 2-18:

Figure 2-18 Front view of the ADUC

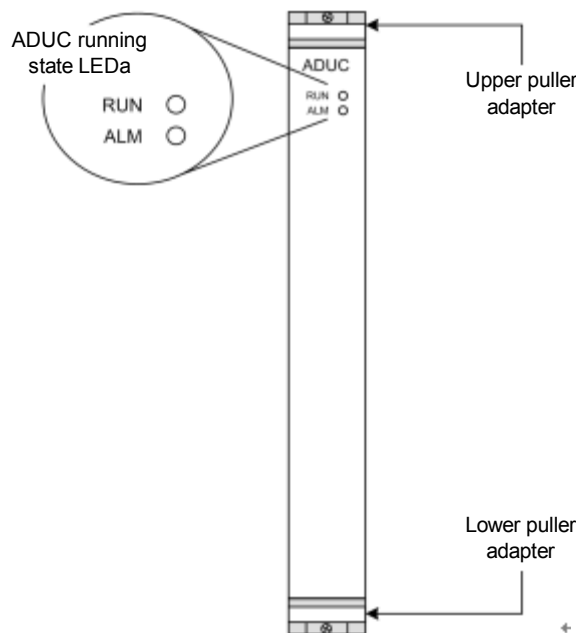

1. 1. 1. 10 Indicators of the ADUC

The front panel of ADUC provides LED indicators showing the ADUC running status. Descriptions of the LEDs are given in the following table.

Table 2-7Status definitions of the LED indicators on the front panel of ADUC

LED	Identification	Color	Status	Description
ADUC running status indicator	RUN	Green	On	The system is powered on
			Off	The system is powered off or abnormal
			Flashing	The ADUC operates normally
	ALM	Red	Off	The ADUC operates normally
			ON	ADUC alarm

2.4. Power Distribution System

2.4.1. Overview

The DC distribution unit of 3P@C 4450E adopts the -48 V DC power supply. It is 4U high and is fixed to the upper part of the equipment rack rear. The -48 V DC input power is divided into 4 tributaries whose outputs are controlled by air switches separately. Their connection relations are shown in Figure 2-19:

Figure 2-19 Connection relations

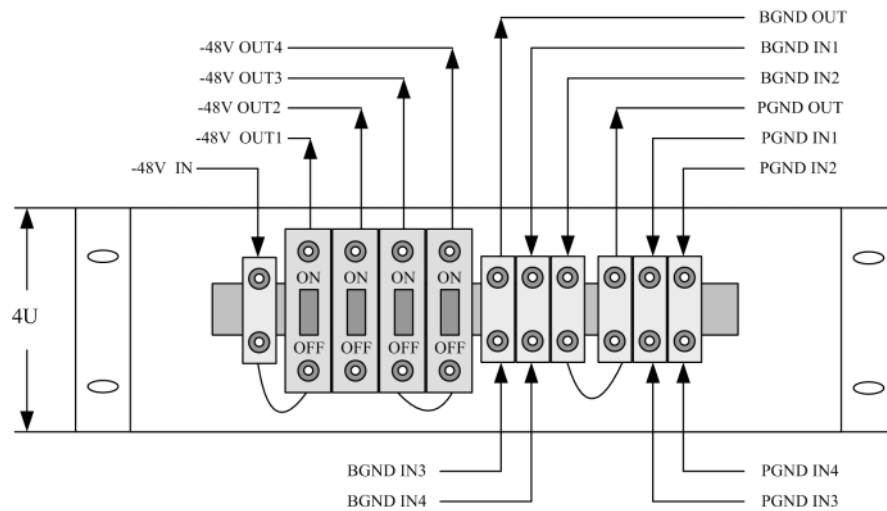

2.4.2. Functional Features

Input requirements

1. -48 V single input.
2. -48 V input range: -36 ~ -72 V DC.
3. -48 V total input power: 3,300 W.

Output requirements

1. The -48 V power is output to 4 channels that are led out by wiring terminals and controlled by air switches.
2. The rated current of the air switch is 32 A.

3. The output power of each -48 V output is 1,200 W.

Cable selection

- The -48V input cable and the BGND and PGND external connection cables are 16mm² blue, black and yellow-green power cables respectively.
- The four -48V output cables and the BGND and PGND internal connection cables are 6mm² blue, black and yellow-green power cables respectively.



prompt

For the connection of DC power supplies, refer to Section 4.3. To connect to the 220 V AC power supply, it is necessary to use the primary power supply system.

2.5. Optional Uplink Interface Modules

The modular structure is adopted for 3P@C 4450E. Each 10U chassis has 16 slots, the former two of which are for inserting the SMUB boards. The SMUB provides multiple optional types of uplink interface modules to meet different user networking requirements. The following uplink interface modules are supported:

Table 2-8 Types of uplink interface modules

Module type	Model	Description
Gigabit interface module	DS-1GLX	1-port gigabit long-wave optical interface module
	DS-1GSX	1-port gigabit short-wave optical interface module
Megabit interface module	DS-2FMM	2-port 100M multi-mode optical interface module
	DS-2FSM	2-port 100M single-mode optical interface module
	DS-4TXB	4-port 100M electrical interface module
	DS-4ITX	4-port 100M electrical interface module
ATM interface module	DS-A155SM	1-port 155M long-wave single-mode ATM optical interface module
	DS-P155MM	1-port 155M short-wave multi-mode ATM optical interface module

The following describes the commonly used gigabit interface module (DS-1GLX/DS-1GSX) and the 100M interface module (DS-2FMM/ DS-2FSM/ DS-4TXB/ DS-4ITX) respectively.

2.5.1. 1-port Gigabit Long-wave Optical Interface Module (DS-1GLX)

The DS-1GLX module provides 1 gigabit long-wave Ethernet optical interface. The physical interface is a standard SC optical interface whose maximum transmission distance is 10 km. A pair of single-mode fibers is required for it. The fiber length and peer interface type depend on the real situation.

1. 1. 1. 11 Structure of the DS-1GLX module

The front panel of the DS-1GLX module is shown in Figure 2-20:

Figure 2-20 Front view of the DS-1GLX module

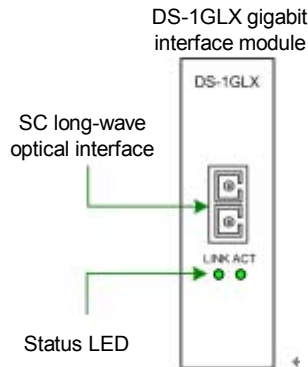

The front panel of the DS-1GLX module is composed of the following parts:

- 1 standard SC gigabit long-wave optical interface
- 1 LINK status indicator
- 1 ACT status indicator

Of the above, the different states of LINK and ACT indicators show the port operating status. For details, refer to Table 2-9.

1. 1. 1. 12 Indicators of the DS-1GLX module

Table 2-9 Status definitions of the LINK and ACT LEDs on the DS-1GLX module

LED	Color	Display state	Description
LINK	Green	Solid on	After a stable connection between a port and the equipment is established, the indicator of the port stays solid on.
		Off	The link on the port is down.
ACT	Green	Flashing	Data are being received/transmitted on the port
		Off	No data are being received/transmitted on the port.

1. 1. 1. 13 Interface features of the DS-1GLX module

Table 2-10 Gigabit long-wave optical interface features of the DS-1GLX module

Module type	Quantity of interfaces	Interface type	Interface attributes	Fiber specifications	Transmission distance
DS-1GLX	1	SC	1000Base-LX	9/125 μm single-mode fiber with a wavelength of 1,310 nm	10km

The fiber system is divided into two types by the optical transmission mode: Multi-mode fibers and single-mode fibers. The single-mode fiber is the fiber that transmits signal in a single mode at the given wavelength. Its core is about 4 ~ 10μm, which is quite small. The fiber features high transmission bandwidth and large transmission capacity.



prompt

To know more about fibers, please refer to the contents in Appendix C.

2.5.2. 1-port Gigabit Short-wave Optical Interface Module (DS-1GSX)

The DS-1GSX module provides 1 gigabit short-wave Ethernet optical interface. The physical interface is a standard SC optical interface whose maximum transmission distance is 550 m. A pair of multi-mode fibers is required for it. The fiber length and peer interface type depend on the real situation.

1. 1. 1. 14 Structure of the DS-1GSX module

The front panel of the DS-1GSX module is shown in the following figure:

Figure 2-21 Front view of the DS-1GSX module

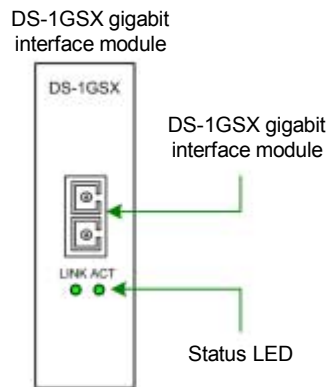

The front panel of the DS-1GSX module is composed of the following parts:

- 1 standard SC gigabit short-wave optical interface
- 1 LINK status indicator
- 1 ACT status indicator

Of the above, the different states of LINK and ACT indicators show the port operating status. For details, refer to Table 2-11.

1. 1. 1. 15 Indicators of the DS-1GSX module

Table 2-11 Status definitions of the LINK and ACT LEDs on the DS-1GSX module

LED	Color	Display state	Description
LINK	Green	Solid on	After a stable connection between a port and the equipment is established, the indicator of the port stays solid on.
		Off	The link on the port is down.
ACT	Green	Flashing	Data are being received/transmitted on the port
		Off	No data are being received/transmitted on the port.

1. 1. 1. 16 Interface features of the DS-1GSX module

Table 2-12 Interface features of the DS-1GSX module

Module type	Quantity of interfaces	Interface type	Interface attributes	Fiber specifications	Transmission distance
DS-1GSX	1	SC	1000Base-SX	62.5/125 μm multi-mode fiber with a wavelength of 850 nm	275m
				50/125 μm multi-mode fiber with a wavelength of 850 nm	550m

The fiber system is divided into two types by the optical transmission mode: Multi-mode fibers and single-mode fibers. A multi-mode optical fiber is a fiber that transmits signals in multiple modes at a given wavelength. Phase difference may occur in the multi-mode transmission because the lights of different modes will transfer at different speeds along a line. As a result, transmission distortion will occur and thus the transmission band will be restricted. Two specifications are available now for the cores of multi-mode optical fibers: 62.5 μm and 50 μm. In ISO/IEC 11801, both the two modes are recognized transmission media.

2.5.3.2-port 100M Multi-mode Optical Interface Module (DS-2FMM)

The DS-2FMM module provides 2 100M multi-mode fast Ethernet optical interfaces. The physical interface is a standard SC optical interface and the multi-mode fiber is used whose maximum transmission distance is 2 km. Two pairs of multi-mode fibers are required for it. The fiber length and peer interface type depend on the real situation.

1. 1. 1. 17 Structure of the DS-2FMM module

The front panel of the DS-2FMM module is shown in the Figure 2-22:

Figure 2-22 Front view of the DS-2FMM module

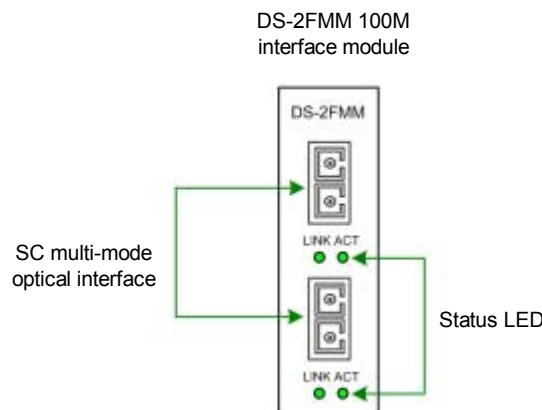

The front panel of the DS-2FMM module is composed of the following parts:

- 2 standard SC 100M multi-mode optical interfaces
- 2 LINK status indicator
- 2 ACT status indicator

Of the above, the different states of LINK and ACT indicators show the port operating status. For details, refer to Table 2-13.

1. 1. 1. 18 Indicators of the DS-2FMM module

Table 2-13 Status definitions of the LINK and ACT LEDs on the DS-2FMM module

LED	Color	Display state	Description
LINK	Green	Solid on	After a stable connection between a port and the equipment is established, the indicator of the port stays solid on.
		Off	The link on the port is down.
ACT	Yellow	Flashing	Data are being received/transmitted on the optical port.
		Off	No data are being received/transmitted on the optical port.

1. 1. 1. 19 Interface features of the DS-2FMM module

Table 2-14 Interface features of the DS-2FMM module

Module type	Quantity of interfaces	Interface type	Interface attributes	Fiber specifications	Transmission distance
DS-2FMM	2	SC	100Base-FMM	62.5/125 μ m multi-mode fiber	2km

2.5.4.2-port 100M Single-mode Optical Interface Module (DS-2FSM)

The DS-2FSM module provides 2 100M single-mode fast Ethernet optical interfaces. The physical interface is a standard SC optical interface and the single-mode fiber is used whose maximum transmission distance is 15 km. Two pairs of single-mode fibers are required for it. The fiber length and peer interface type depend on the real situation.

1. 1. 1. 20 Structure of the DS-2FSM module

The front panel of the DS-2FSM module is shown in the following figure:

Figure 2-23 Front view of the DS-2FSM module

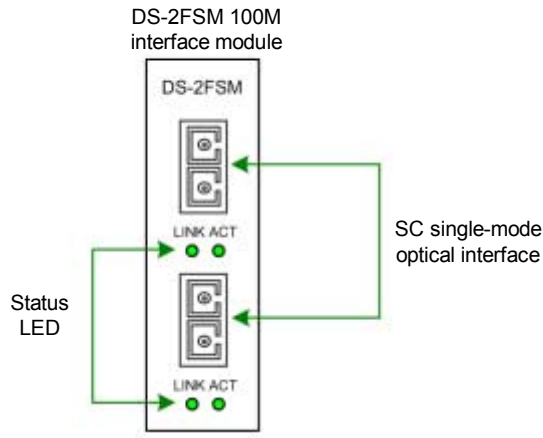

The front panel of the DS-2FSM module is composed of the following parts:

- 2 standard SC 100M single-mode optical interfaces
- 2 LINK status indicator
- 2 ACT status indicator

Of the above, the different states of LINK and ACT indicators show the port operating status. For details, refer to Table 2-15.

1. 1. 1. 21 Indicators of the DS-2FSM module

Table 2-15 Status definitions of the LINK and ACT LEDs on the DS-2FSM module

LED	Color	Display state	Description
LINK	Green	Solid on	After a stable connection between a port and the equipment is established, the indicator of the port stays solid on.
		Off	The link on the port is down.
ACT	Yellow	Flashing	Data are being received/transmitted on the optical port.
		Off	No data are being received/transmitted on the optical port.

1. 1. 1. 22 Interface features of the DS-2FSM module

Table 2-16 Interface features of the DS-2FSM module

Module type	Quantity of interfaces	Interface type	Interface attributes	Fiber specifications	Transmission distance
DS-2FSM	2	SC	100Base-FSM	9µm single-mode fiber	15km

2.5.5.4-port 100M Electrical Interface Module (DS-4TXB)

The DS-4TXB module provides 4 100M fast Ethernet electrical interfaces. The physical interface is an RJ-45 connector and the C5 twisted pair cable is used whose transmission distance is 100 m. The MDI/MDIX self calibration function is supported. The cable length and peer interface type depend on the real situation.

1. 1. 1. 23 Structure of the DS-4TXB module

The front panel of the DS-4TXB module is shown in the following figure:

Figure 2-24 Front view of the DS-4TXB module

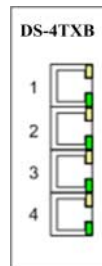

The front panel of the DS-4TXB module is composed of the following parts:

- 4 RJ-45 10/100M Ethernet electrical interfaces
- 4 ACT indicators
- 4 LINK indicators

Of the above, the different states of LINK and ACT indicators show the port operating status. For details, refer to Table 2-17.

1. 1. 1. 24 Indicators of the DS-4TXB module

Table 2-17 Status definitions of the LINK and ACT LEDs on the DS-4TXB module

LED	Color	Display state	Description
LINK	Green	Solid on	After a stable connection between a port and the equipment is established, the indicator of the port stays solid on.
		Off	The link on the port is down.
ACT	Yellow	Flashing	Data are being received/transmitted on the port
		Off	No data are being received/transmitted on the port.

1. 1. 1. 25 Interface features of the DS-4TXB module

Table 2-18 Interface features of the DS-4TXB module

Module type	Quantity of interfaces	Interface type	Interface attributes	Fiber specifications	Transmission distance
DS-4TXB	4	RJ-45	10/100Base-TX	Category-3/4/5 shielded/unshielded twisted pairs	100m

2.5.6. VAS Card (DS-4ITX)

The VAS card (DS-4ITX) is developed to meet the growing demands of users for IN services. Currently, it provides L2TP VPDN service, PPPoE Server Proxy service, network interface PPPoE termination service, and VMAC service. It will provide the MPLS VPN service in the future.

Through software configuration, the VAS card can be loaded with different IN service FPGA logics to support diversified IN services and flexibly meet the new market requirements.

The DS-4ITX module provides 4 100M fast Ethernet electrical interfaces. The physical interface is an RJ-45 connector and the C5 twisted pair cable is used whose transmission distance is 100 m. The cable length and peer interface type depend on the real situation.

1. 1. 1. 26 Structure of the DS-4ITX module

The front panel of the DS-4ITX module is shown in the following figure:

Figure 2-25 Front view of the DS-4ITX module



The front panel of the DS-4ITX module is composed of the following parts:

- 4 RJ-45 10/100M Ethernet electrical interfaces
- 4 ACT indicators
- 4 LINK indicators

Of the above, the different states of LINK and ACT indicators show the port operating status. For details, refer to Table 2-19.

1. 1. 1. 27 Indicators of the DS-4ITX module

Table 2-19 Status definitions of the LINK and ACT LEDs on the DS-4ITX module

LED	Color	Display state	Description
LINK	Green	Solid on	After a stable connection between a port and the equipment is established, the indicator of the port stays solid on.
		Off	The link on the port is down.
ACT	Yellow	Flashing	Data are being received/transmitted on the port
		Off	No data are being received/transmitted on the port.

1. 1. 1. 28 Interface features of the DS-4ITX module

Table 2-20 Interface features of the DS-4ITX module

Module type	Quantity of interfaces	Interface type	Interface attributes	Fiber specifications	Transmission distance
DS-4ITX	4	RJ-45	10/100Base-TX	Category-3/4/5 shielded/unshielded twisted pairs	100m

2.6. Route Transfer Unit (RTU)

At present, some special application modes of 3P@C 4450E need to be supported by the RTU, including the non-PPPoE packet filtering and user name binding in the L2 PPPoE transparent transmission mode.

With the board structure, the RTU is composed of such components as chips, crystal oscillators and resistance-capacitance devices. It does not provide any external interface. It is installed on the SMUB (see Section 4.4.2 for its installation) and connected to the socket on the SMUB via the pins on the board to provide the L3 routing and flow table functions. Its structure is shown in the following figure.

Table 2-21 Structure of the RTU



The RTU is optional. You may use it as required.

- When 3P@C 4450E uses the 100M electrical interface uplink interface module, though the RTU routing function can be provided, the L2 application mentioned above will be limited. To perfectly support the L2 application, it is necessary to add the RTU.
- When 3P@C 4450E uses the gigabit electrical interface uplink interface module, the L2 application mentioned above can be implemented without using the RTU.

When 3P@C 4450E uses the ATM interface uplink interface module, the RTU must be adopted so as to provide the L2 application function mentioned above and the L3 function.

CHAPTER 4

3. Installation Preparation

3.1. Environmental Requirements

3.1.1. Temperature and Humidity Requirements

To ensure the normal running of the equipment and prolong its service life, please make sure that the temperature and humidity of the equipment room are within the allowed range of the equipment operation.

The temperature shall range within $-5^{\circ}\text{C} \sim +50^{\circ}\text{C}$ and the indoor temperature range of $18^{\circ}\text{C} \sim 25^{\circ}\text{C}$ is recommended. Too high temperature will do great harm to the equipment and long-term high temperature will accelerate the ageing of insulation materials, reduce the running stability of components and even affect the service life of the equipment.

The humidity range shall range from 5% to 95%, preferably 20% ~ 60%. Too high humidity inside the equipment room may cause poor insulation performance of the insulation materials or even current leakage, which will cause short circuit or fire disaster. In addition, too high humidity will also cause changes of the mechanical performance of the materials, oxidization of the metal part and corrosion. However, too low humidity will cause the generation of static electricity.

3.1.2. Cleanness Requirements

Certain cleanness is required for the operating environment of the equipment and dust should be avoided as much as possible, because dust will cause harm to the safe running of the equipment. When dust falls down on the equipment body, it can cause static absorption and result in poor contact of the metal plug-ins or metal contact points, especially when the indoor RH is slightly lower. This will not only affect the service life of the equipment but also cause communication failure. Furthermore, the dust falling down on the optical interface of an interface module installed in the equipment will severely affect the interface data transmission or even cause transmission interruption. Therefore, dustproof measures must be taken for the equipment room where the equipment operates. It is recommended that the concentration of particles be less than $180 \text{ mg}/\text{m}^3$ and such devices as printers and copying machines be placed as far as possible from the equipment, so as to prevent paper scraps and ink powder from being absorbed into the equipment inside.

3.1.3. Floor Requirements

The equipment room floor shall first of all satisfy the bearing capacity requirement and it should be dust proof, fire proof, insulated and wearproof. The floor can be made of linoleum flooring, ethylene perchloride, resinous varnish or can be the anti-static raised floor. The antistatic floorboards should be tightly fit and robust, with the horizontal error no greater than 2mm per square meter. The ground or floor must be statically grounded and the resistance of the unit raised floorboards should accord with the *Technical Specification for the Raised Floor in Computer Rooms*. The floor can be connected to the grounding device via a current-limiting resistor and connection line.

The load bearing capacity of the equipment room floor should be more than 450 kg/m² (when storage batteries are contained in the cabinet). Considering the weight of the lead-acid battery, the load bearing capacity of the floor of the battery room should be more than 500 kg/m² when equipped with the battery below 500AH and more than 600 kg/m² when equipped with the battery above 800AH. The load bearing capacity of both the corridor and staircase should be 400 kg/m² (where there is no storage battery), with the overload coefficient being 1.4. The load bearing capacity of other places except for the equipment room should not be lower than 300 kg/m². In case of old buildings, the load bearing capability should be improved if the indices do not satisfy the requirements.

3.1.4. Heat Dissipation Requirements

Good ventilation should be ensured for the operating environment of the equipment so as to meet the heat dissipation requirements of the internal components of the equipment. In particular, sufficient space (no less than 0.8 m) is required for both the front face and the rear face of the equipment at the place near the fans. Air inlet and outlet should not be blocked and weights are not permitted on the equipment.

3.1.5. Power Supply Requirements

When -48V DC power is adopted to supply power to 3P@C 4450E, the allowed variation of the voltage should be -36V ~ -72V when measured at the DC input terminal of each cabinet. When the conductor of the DC discharge loop is selected, the through voltage dip of the DC discharge loop should be no more than 0.5V and the core diameter of the DC power cable should be no less than 16mm².

When AC power supply is adopted, reliable and stable AC mains power and lead-in wires should be selected. Since 3P@C 4450E consumes little power, it can adopt the 220V single-phase three-wire power supply system after conversion by the power transformation equipment. The specifications of the power cable should be calculated according to the equipment quantity and their power consumption, so as to meet the relevant specification requirements and taken into account sufficient security. In its full configuration, the 3P@C 4450E switch needs more than 1200W power.

3.1.6. Grounding Requirements

When 3P@C 4450E is used in a large data communication office and is installed in a 19-inch cabinet with DC power supply, according to the General Technical Requirements (Provisional) for the Power Supply System of a Communication Office (Station) issued by the former Ministry of Posts and Telecommunications, the working ground, the protection ground of all communication equipment as well as the lightning protection ground of the building where the communication office of 3P@C 4450E is located should share a centralized grounding mode via a group of grounding devices, i.e. joint grounding mode.

When AC power supply is adopted for 3P@C 4450E, the power sockets (as shown in Figure 3-1) using neutral point connectors are recommended and the neutral point of the power cable should be reliably grounded in the building. Generally during the engineering cabling of the building, the neutral points of the power supply system of the building have been buried and users should confirm if the power supply of this building has been reliably grounded.

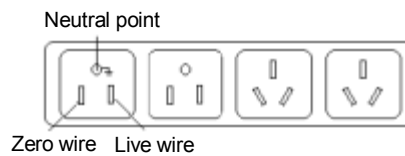
Figure 3-1 Recommended power sockets

In order to ensure the definitely safe operation of the equipment, grounding in accordance with the grounding treatment requirements is needed. At the upper back of the 3P@C 4450E cabinet, one end of the grounding cable can be fixed and mounted at the grounding terminal while the other end can connect the protection ground of the equipment room, or it can be buried under the ground or connected to the grounding body inside the equipment room. The grounding resistance of the grounding body should be less than 1 ohm and copper conductors with good conductivity should be selected as the grounding cables with the section area no less than 16mm².

The following grounding requirements are posed for 3P@C 4450E:

- The grounding cables should be led into the equipment room by the horizontal grounding busbar of the vertical grounding bus in the joint grounding device. The grounding cable of each rack of the 3P@C 4450E equipment should be led into the nearest horizontal grounding bus.
- The DC power supply working ground of each rack in the 3P@C 4450E equipment should be connected from the grounding bus.
- Each rack equipment should have the working ground. The shell and cabinet should have the protection ground.
- The distribution frame should be connected with the protection ground via the grounding bus. Meanwhile, the distribution frame should not be electrically connected with the cabinet.
- All communication equipment in the equipment, except for the grounding cable close to the grounding bus, are not allowed to form the electrical connection by the installed fastening bolts touching the steel reinforcement in the building.
- The section area of the grounding cables (including the wires connecting the cabinets to be grounded/the grounding wires with the horizontal grounding busbars) should be determined on the basis of the possible maximum current load. The grounding cables should be made of good conductors (copper) and naked conducting wires are not allowed.
- The joint grounding resistance of the communication office where the 3P@C 4450E is located should be less than 2 ohm.
- The metal parts (e.g., walls and reinforcing steel bars inside pillars) of the building itself should be preferably used as the downleads of the lightning protection ground, and such downleads shall be electrically connected with one another to balance the electric potential inside the building. The working ground of 3P@C 4450E should be far away from the power equipment or the grounding devices of the lightning protection ground as much as possible.
- The grounding terminals must undergo anti-corrosion and anti-rust processing. Meanwhile, the screws should all be tightened to ensure good contact.
- Do not lay down the grounding cables and signal cables in parallel or in a twisted manner to reduce their mutual interference.



prompt

The basic requirement of grounding is that the grounding resistance should be little. During the engineering design, low-resistance grounding materials should be applied with sufficient length, width and thickness to ensure that 3P@C 4450E meets the grounding requirements. Ground piles can be buried deeply under the ground to form a flat surface there, so as to ensure low resistance for various frequencies. As the type of soil impacts the grounding resistance most, chemical agents (resistance-reducing agents) can be applied around the ground pile to reduce resistance for areas where the soil conditions are poor. Furthermore, the temperature and humidity of soil also have impact on the grounding resistance and this should also be considered during the engineering design.

3.1.7. Anti-interference Requirements

Any interfering sources from the equipment or outside the applied system may affect the equipment in the capacitance coupling, inductance coupling, electromagnetic wave radiation, common resistance (including the grounding system) and the conduction mode of conducting wire (power supply line, signaling line and output wire). For this reason, note that:

- Take effective power anti-interference measures for the power supply system.
- Do not combine the working ground of 3P@C 4450E with the grounding device or the lightning grounding device of the power equipment but keep the distance between them as far as possible.
- Keep far away from any large-power radio transmitting station, radar transmitting station and high frequency strong current equipment.
- Take electromagnetic shielding measures when necessary.

3.1.8. Other Requirements

- The indoor should be bright enough for operation, preferably 500 ~ 750 lumen/m².
- The equipment room should be attended by designated persons or have other burglar-proof measures.
- The water supply and draining systems of the equipment room should be designed in accordance with the normal water consumption and fire fighting regulations, and sufficient fire protection devices should be equipped.

3.2. Safety Requirements

3.2.1. Basic Safety Requirements

To ensure the normal operation of the equipment and the human safety, please strictly obey the following security instructions during the operation:

- Carefully operate the equipment in accordance with the instructions given in this manual.
- Turn off the power before the equipment installation.
- Confirm whether the power supply is connected.
- Connect the power supply to a grounded socket to meet the European safety standards.
- Try not to place the power supply socket far away from the power inlet of the equipment, so that the power socket can be directly turned off without removing the power cable connected to the equipment in the case of power supply failure.
- Avoid any liquid contacting the equipment, lest short circuits or current leakage be caused.
- Never place the equipment near any heat source, lest the operation performance of the equipment be deteriorated or even the equipment be damaged. In addition, avoid direct sunshine on the equipment.
- Clean the equipment with soft and clean dry cloths and do not use any detergents.
- Do not wear any loose dress or jewelry (such as rings, necklace and bracelet). Preferably the sleeves should be rolled during the operation. Make sure that the installation of the switch on the rack will not entangle your clothes.

3.2.2. Antistatic Requirements

Many antistatic measures have been taken for 3P@C 4450E. However, if the static electricity in the environment exceeds a certain range, it will cause damage to the circuits or even the whole equipment; therefore, static electricity should be taken into account during the design of the equipment room environment. The static induction comes from two aspects: 1) outside electric field, such as high voltage power transmission lines and lightning stroke; 2) internal system, such as indoor environment, floor materials and equipment structure.

Therefore, in order to avoid the damages caused by static electricity, please make sure to:

- Ground the equipment and the floor well;
- Keep the equipment room inside dust-proof;
- Maintain appropriate temperature and humidity conditions;
- The human static electricity can also damage the printed circuits and the internal components. Therefore, when you touch the circuit board or the extended module, please hold the edges of them instead of directly touching the circuits or components to avoid damage to them caused by human static electricity. Where necessary, wear an antistatic wrist strap and antistatic work uniform during the operation.

3.2.3. Avoiding Laser Damage

- While the equipment installed with a fiber interface module is operating, please do not expose your eyes directly to these optical interfaces, lest the laser ray from the interfaces cause eye damage.
- It is suggested that protection covers for optical interfaces be placed on those optical interfaces if they are not in use.
- Wear safety glasses to protect your eyes if condition permits.

3.2.4. Lightning Protection Requirements

The equipment room building, if higher than 15 m, should be designed in accordance with the lightning protection requirements for Class II civil buildings and structures.

During the anti-lightning design, measures should be taken to guard against the incursion of direct stroke and the lightning current. In the areas where lightning occurs frequently, there is also the phenomenon of side flash. So, some preventive measures against the side flash should be adopted according to the actual situation during the design. For example, connect the outer metal windows of the building with the lightning protection down lead. Along the height of the building, set horizontal metal lightning protection straps on the outer wall at a certain interval to prevent the lightning.

The following lightning protection measures shall be taken for the main building body of the equipment room.

- Install anti-lightning nets or anti-lightning straps on the parts of the building that are subject to lightning.
- Equipment the protruding objects such as the chimney, antenna with an overhead conductor or arrester.
- Ensure the sectional area of the downlead of the anti-lightning device is no less than 2 mm^2 , and their spacing is no more than 30 m.

The grounding resistance of the building's lightning protection grounding device should be no more than 10 ohm. Before external cable and metal pipes etc. enter the building, they should be grounded. When outdoor aerial cables directly enter a room, lightning arrester should be installed at the point of entry. At the top of chimneys or antennas etc., lightning rods or lightning protection rings should be added. For buildings and structures, it is advisable to use the steel reinforcement of the reinforced concrete building slabs, beams, pillars and foundation as the discharge line for lightning-protection devices.

In the past, the lightning protection ground of the building was separated from the ground of telecom and power supply systems, and large distances were required between various grounding devices. However, due to such reasons as small building sites, most of these requirements of distance were not satisfied. In fact, they can not be separated in many circumstances, so it is advisable to employ joint grounding systems for the lightning protection of the buildings. The joint grounding system connects the operating ground and protection ground for telecom use and the lightning protection ground of the building as well as the ground of the industrial frequency AC power supply system together. The grounding resistance of joint grounding should be quite high. Since the grounding resistance required for telecom is far less than 10 ohm, while the grounding requirements for various telecom equipments are different, the joint grounding resistance shall be determined according to the minimum resistance value of the various grounding devices.

It is advisable to employ the metal components of the building itself (such as reinforcing steel bars inside walls and pillars) as the lead wires for lightning protection grounding, and these lead wires should be electrically connected, so that the electric potentials inside the building are equilibrated.



To ensure the operation safety of the electrical interfaces on the equipment, lightning protection measures must be taken when the connection of the equipment involves outdoor cabling.

3.2.5. Anti-seismic Design Requirements

The quakeproof intensity of telecom equipment building should be designed one degree higher than local construction intensity. Those equipment buildings in short of quakeproof intensity requirements have to be strengthened. The construction departments should be invited to join the design and its execution.

3P@C 4450E uses the following measures during the installation to withstand Richter 7 earthquake.

- The 10U chassis of 3P@C 4450E uses light and strong aluminium alloy structure. There are locking devices to fix the circuit boards within the cabinets.
- When combining several cabinets together in the installation, you can lock the top between the two cabinets by two cabinet-combining boards, so that the multiple cabinets are lined up to form integrity.
- Consolidate the reinforcement between the cabinet of 3P@C 4450E and the equipment room. Fasten the cabinet with the floor via its supports and feet. When necessary, fasten the cabinet with the ceiling to make the cabinet integrated with the equipment room framework.

3.2.6. Fireproof Design Requirements

The fireproof design of the equipment room should accord with the *Code of Design on Building Fire Protection and Prevention* issued by the state. As a key fire protection unit, any communication building shall have its fire-proof class reaching Class II and Class I (for high-rise buildings). In the equipment room of 3P@C 4450E, emergency fire extinguishers should be equipped and automatic fire alarm systems are recommended inside the equipment room.

3.2.7. Precautions for Equipment Handling

- Preferably two or more persons are needed to move the equipment, lest the big weight of the equipment accidentally cause damage to the human body.
- Before dismounting or moving the equipment, cut off its power first.

3.3. Installation Tools and Materials

Unpack and inspect the equipment before installing it and place its components at a safe place. When moving parts, please wear gloves lest that any sweat should corrode the metal parts of the equipment.

The following tools are needed to install 3P@C 4450E:

- One cross screwdriver
- One straight screwdriver
- One spanner
- One pair of hydraulic pliers

- One pair of scissors
- One level bar
- One percussion drill
- One dust cleaner
- Anti-static wrist strap

If the equipment is to be installed on the antistatic floor, an additional electric saw should be prepared before the formal installation.

The following cables are needed for connection:

- Power cables
- Serial port console cables
- Grounding cables
- Network cables or fibers

Others that are needed include:

- A computer with HyperTerminal software installed
- The modules to be installed

3.4. Product Configuration List

3.4.1. Basic Configuration of the Product

Table 1-1 Basic configuration list of 3P@C 4450E

Item	Name	Quantity	Description
1	3P@C 4450E-IPDSLAM-10U general chassis kit	1 PCS	Including a 10U chassis, a backplane, a fan module, a fan mounting support and an air deflector frame
2	Accessories for installation	1 suite	Including engineering labels, cable ties, screws and RS-232C console cables
3	DC power cable	1 PCS	Cut as required
4	Grounding cable	1 PCS	Cut as required

3.4.2. Optional Components

Table 1-2 List of the optional components for 3P@C 4450E

Item	Optional Component	maximum configuration	Accessories Needed
1	Service Processor Unit Board (SMUB)	2	-----
2	VDSL Unit Board (VDUB)	14	A suite of subscriber cables
3	ADSL Unit Board/Card (ADUB, ADUC)	14	A suite of subscriber cables
4	Route Transfer Unit (RTU)	1	-----
5	1-port gigabit long-wave single-mode interface module (DS-1GLX)	2×2	-----
6	1-port gigabit short-wave multi-mode interface module (DS-1GSX)	2×2	-----
7	4-port 100M electric interface module (DS-4TXB)	2×2	-----
8	VAS card (DS-4ITX)	2×2	-----

Item	Optional Component	maximum configuration	Accessories Needed
9	2-port 100M multi-mode optical interface module (DS-2FMM)	2×2	-----
10	2-port 100M single-mode optical interface module (DS-2FSM)	2×2	-----
11	1-port 155M long-wave single-mode ATM interface module (DS-A155SM)	2×2	-----
12	1-port 155M short-wave multi-mode ATM interface module (DS-A155MM)	2×2	-----



prompt

The maximum configuration quantity given in the above table is applicable to each general chassis of 3P@C 4450E.

3.5. Unpacking for Acceptance



Note

Keep the equipment waterproof and shock-proof during its transportation. After the equipment arrives at the destination for installation, do not handle it roughly but keep it away from sunlight and rain.

3.5.1. Preparation

1. 1. 1. 29 Checking the packages

Before unpacking, check if the packing box is intact and if the equipment model is consistent with that specified in the purchase contract.



Note

If the packing box is damaged or the equipment model is inconsistent, please keep the original condition and contact the local office of SAGEM sa.

1. 1. 1. 30 Unpacking tools

The needed tools for unpacking include a claw hammer or screwdriver and an antistatic wrist strap.

1. 1. 1. 31 Participants

Both the customer and the engineering staff (engineers or representatives of SAGEM sa) should be present during the unpacking. Otherwise, any goods problem shall be borne by the unpacking party.

1. 1. 1. 32 **Storage environment requirements**

- Temperature: 10°C ~ 30°C.
- Humidity: 30% ~ 70%.
- There should be basically vibration-free, low dust concentration and free of strong electromagnetic interference with good antistatic measures taken and wide site space.



prompt

Preferably you should unpack inside or near the equipment room to avoid hard moving of the equipment or damaged to the equipment.

3.5.2. Unpacking

1. 1. 1. 33 **Packing box of the general chassis**

The assembly wooden box is used as the packing box of 3P@C 4450E. It is connected and fixed with plastic clips. Figure 3-2 shows its outside view.

Figure 3-2 Appearance of the packing box

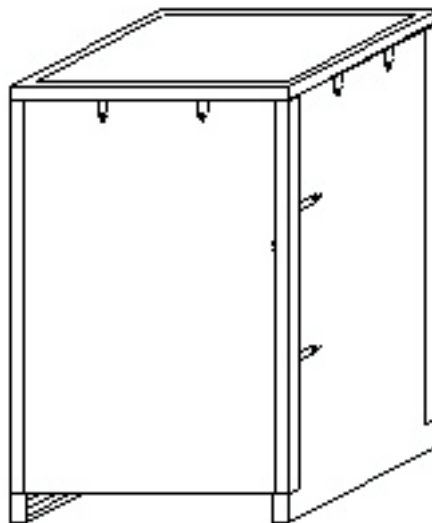

Inside the packing box, there are packing materials such as foam pad, antistatic plastic bag and desiccants. The equipment is placed in the antistatic plastic bag. Its upper edge, bottom edge and all the corners are protected with the foam pads, and the foam pads are connected and fixed with paper boards, as shown in Figure 3-3:

Figure 3-3 Packing structure of the equipment inside the packing box

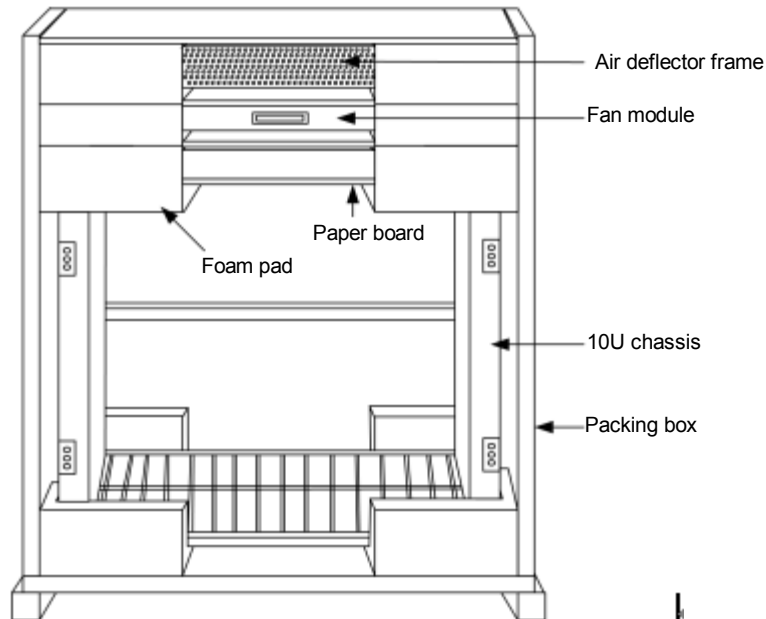

prompt

The above figure indicates the structure of the packing box inside and shows the packing materials such as antistatic plastic bag and desiccant.

To unpack the packing box, take the following steps:

Step 1	Remove the outside packing materials. Place the packing box as indicated and use a claw hammer or screwdriver to remove the plastic clips around the top cover. The upper cover can be opened.
Step 2	Remove the equipment packing materials. Remove the packing materials (e.g. foam pads) on the equipment and carefully and smoothly draw out the equipment. Remove the packing plastic bag of the equipment.



Note

If the equipment is moved from a place with low temperature and low humidity to another place with high temperature and high humidity, you have to wait at least 30 minutes before unpacking it so as to avoid damages to the equipment caused by the moisture condensed on the equipment surface.



Note

Since the equipment is rather heavy, please operate it carefully and avoid colliding with human or articles. Raise and hold rigid places such as the rack base and skeleton to avoid damaging the equipment or any other accidents.

1. 1. 1. 34 Packing box of accessories

The packing box of accessories uses a small carton. Inside it there are a User Manual, a user registration/warranty card, an antistatic wrist strap, subscriber cables and suite of packing materials.

1. 1. 1. 35 Packing box of boards

The packing box of boards usually adopts a carton. Inside the packing box, there are packing materials such as foam pad, antistatic plastic bag and desiccants. After opening the carton, wear an antistatic wrist strap first before taking the board out of the antistatic bag.



1. If a board is moved from a place with low temperature and low humidity to another place with high temperature and high humidity, you have to wait at least 30 minutes before unpacking it so as to avoid damages to the board caused by the moisture condensed on the board surface.
 2. You must wear an antistatic wrist strap before taking out the board to avoid damage.
-

1. 1. 1. 36 Cabinet packing box

The assembly wooden box is used as the packing box of the cabinet. It is connected and fixed with plastic clips. Figure 3-4 shows its outside view. Inside the packing box, there are packing materials such as foam pad, plastic bag, desiccant, cabinet, marking template and cabinet installation instructions. The cabinet is placed in the antistatic plastic bag. Its upper edge, bottom edge and all the corners are protected with the foam pads, and the foam pads are connected and fixed with paper boards. Inside the cabinet there are guide rails.

Figure 3-4 Appearance of the cabinet packing box

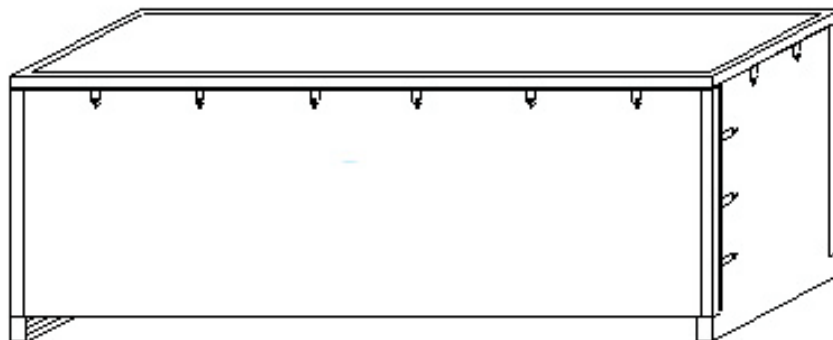

To unpack the packing box of the cabinet, take the following steps:



<p>Step 1</p>	<p>Open the upper cover. Place the packing box as indicated and use a claw hammer or screwdriver to remove the plastic clips around the top cover. The cabinet is exposed.</p> <div style="text-align: center;">  <hr/> <p>prompt</p> </div> <p>Since the cabinet is rather heavy, three to four persons are needed to cooperate with one another in the unpacking process.</p>
<p>Step 2</p>	<p>Erect the packing box and pull out the two cabinet feet. Erect the packing box to its normal position. Hold the packing box and carefully drag outward the cabinet from the side where the cover is removed, until the two cabinet feet are dragged out of the packing box. Remove the foam pads under the cabinet feet and place the cabinet feet on the floor.</p>
<p>Step 3</p>	<p>Slightly lean the packing box along with the cabinet towards the side where the cover is removed, and use the supports of the two cabinet feet on the floor to draw back the packing box from the reverse direction, as shown in Figure 3-5.</p> <div style="text-align: center;">  <hr/> <p>prompt</p> </div> <p>Since the equipment is rather heavy, please operate it carefully. Raise and hold rigid places such as the rack base and skeleton to avoid damaging the equipment or any other accidents.</p>

Figure 3-5 Draw out the packing box backward from the reverse direction



Step 4	Remove the packing materials of the cabinet such as the plastic bag.
Step 5	Take out the marking template and the guide rails inside the cabinet.

3.5.3. Goods Acceptance

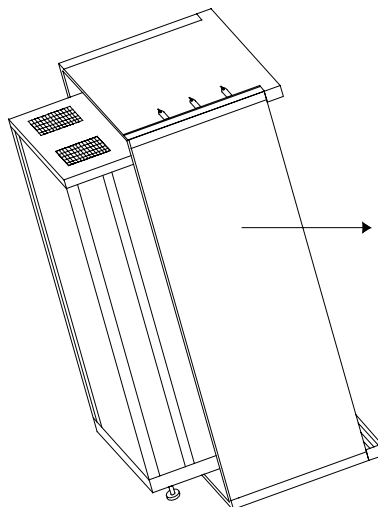
After unpacking, inspect and accept the goods against the contract and the packing list as follows:

- Appearance check: Check if the outer appearance of the equipment has any defect, looseness or damage, and if the identifying words are legible, and if the chassis boards and decorating plates are all installed and meet the requirements for use.
- Integrity check: Check if all the components and accessories needed for installation of the equipment are complete and matched.
- The engineering staff (engineers or representatives) of SAGEM sa should take the main responsibility for checking electrically sensitive devices and components.
- Lay out the inspected goods according to their different types. Keep the unpacked packing box at least till the user signs on the packing list.

The following basic assemblies are contained inside the packing box of 3P@C 4450E:

- One set of 3P@C 4450E equipment (including a 10U chassis and the backplane)
- One fan module and one fan mounting support
- One air deflector frame
- One suite of installation accessories (including engineering labels, cable ties and screws)
- Suite of subscriber cables
- DC power cable
- One RS-232C console cable
- One User Manual
- User registration/warranty card



prompt

The assemblies of the actual purchased equipment and the specific quantities of the components/accessories shall depend on the onsite packing list or the purchase contract of the purchased equipment.

If there is any product damaged or even lost in the box, contact the distributor or the most available salesmen of SAGEM sa. Also please keep away all the packing materials for future packing of the switch.

CHAPTER 4

4. Equipment Installation and Connection



Note

Do not take down the “no dismount” seal of SAGEM sa on the chassis of 3P@C 4450E without prior consent of SAGEM sa. This seal must be intact before the agent or engineer of SAGEM sa maintain the 3P@C 4450E equipment you have purchased. If you really need to dismount the chassis cover, please contact your agent to get the permission first. Otherwise, any consequences such as lack of maintainability caused by arbitrary operations shall be born by the user itself.

Only qualified technicians are allowed to install and maintain 3P@C 4450E and these technicians must receive sufficient technical training or have rich installation and operation experience.

Before installing 3P@C 4450E, check if the needed installation tools and materials are complete. Then remove the packing box of the equipment, take out the equipment and place in on the flat floor. Next, you can install the equipment in the following steps:

To install 3P@C 4450E, take the following steps:

Step 1	Install the 19” standard cabinet 2.2 m high.
Step 2	Install the equipment.
Step 3	Connect the power and grounding cables.
Step 4	Install the Service Processor Unit Board (SMUB).
Step 5	Install the service cards such as ADUB, ADUC and VDUB.
Step 6	Install dummy panels.
Step 7	Connect the subscriber cables.
Step 8	Connect the console cable.

4.1. Cabinet Installation

By the specific equipment room environment, the 19-inch standard cabinet 2.2 m high can be installed on the cement floor or antistatic floor inside the equipment room. Figure 4-1 shows the flow chart of cabinet installation.

Figure 4-1 Cabinet installation flow chart

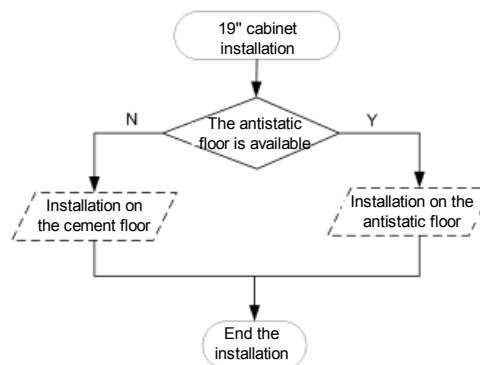



The cabinet of 3P@C 4450E weighs about 150 kg and so two professional installers are needed to install it. The side of the rack shall not be less than 0.1 m away from the wall surface, and the back of the rack shall keep a space of more than 0.8 m from the wall surface and other equipments (including the operation console chairs/desks), so as to facilitate heat dissipation and equipment maintenance. The distance between the front face of one cabinet row and that of its adjacent row should be no less than 0.8 m.

The equipment installation space is illustrated in Figure 4-2.

Figure 4-2 Equipment installation space

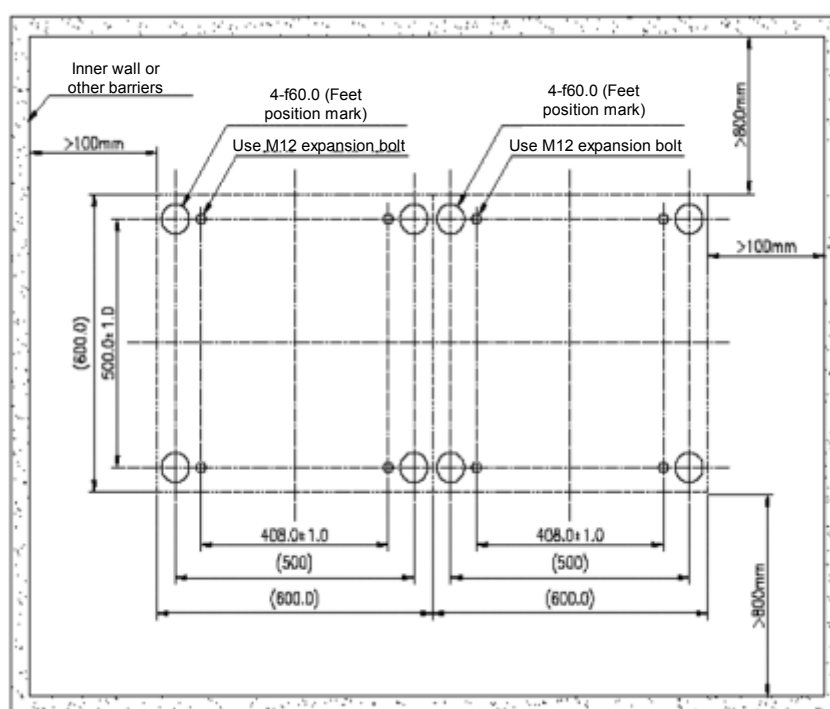

4.1.1. Installation on the Cement Floor

The 19-inch cabinet 2.2 m high is installed on the cement floor by using pressure plates to press on the feet. Since the feet have the insulating function and the pressure plate assembly contains insulating parts, the whole equipment is insulated from the earth before the grounding cable is connected and the insulating requirements can be effectively satisfied. See Figure 4-3 for the installation flow.

Figure 4-3 Flow of cabinet installation on the cement floor

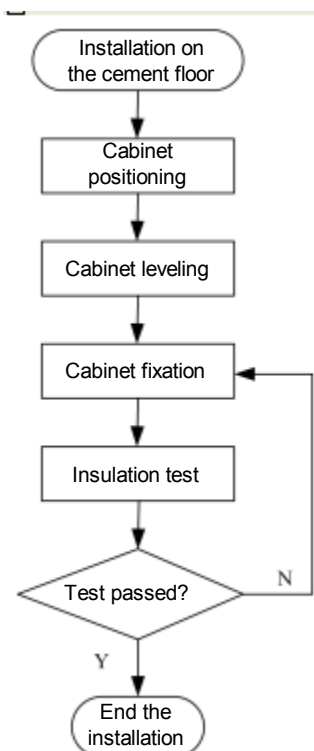

1. 1. 1. 37 Position the cabinet

A. Marking

Decide the positions to install the expansion bolts according to the reference size and the positions of the feet in the construction plane design drawings. Determine the mounting hole positions of the 2.2m cabinet and locate the mounting hole positions of the feet with a marking template. (Note that the marking template is made of rigid paper boards, placed in the packing wooden box of the 2.2 m standard cabinet and delivered along with the cabinet). To avoid errors, repeat the measurement against the installation hole location diagram after all the hole positions have been marked and make sure their sizes are correct. Figure 4-4 shows the mounting hole layout of a single cabinet and Figure 4-5 shows that of two cabinets.

Figure 4-4 Mounting hole positions for a single cabinet

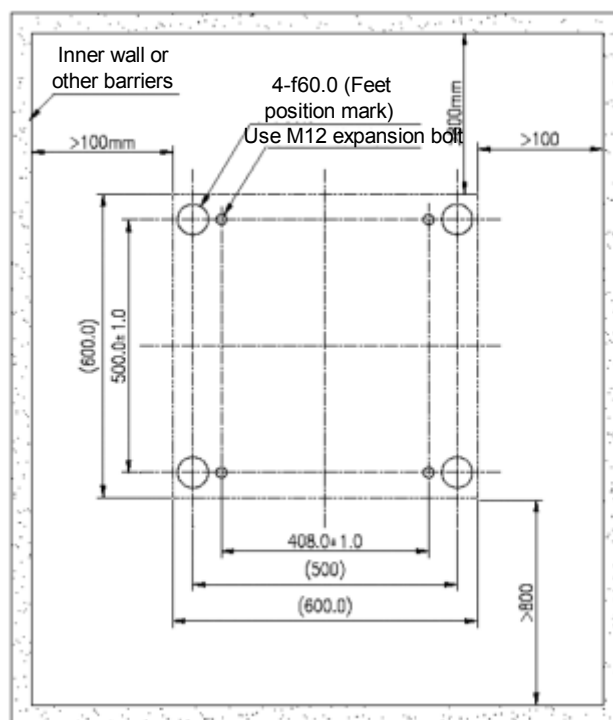
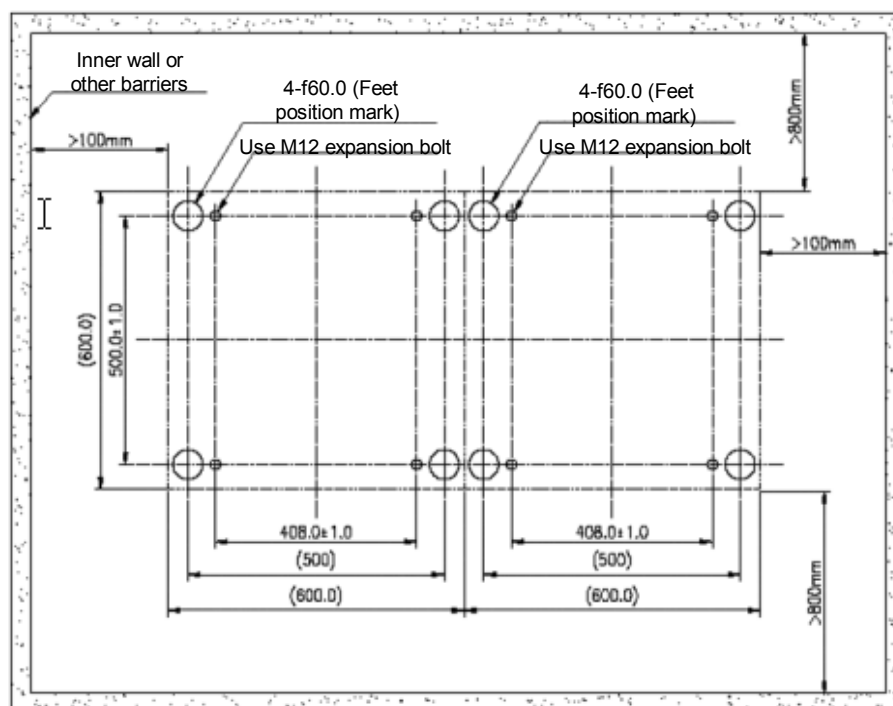

Figure 4-5 Mounting hole positions for two cabinets



B. Drilling

Drill a hole in the place marking expansion bolts with a percussion drill. The drill bit should be $\Phi 14$ or $\Phi 16$. To drill a hole, keep the drill bit vertical with the surface and hold tightly the drill handle and do not shake, lest the surface be damaged and the hole be slanted. The depth of the hole should be the length of the expansion bush plus the cone. All holes must be consistent in the depth. Remove the dust out of the hole while measuring the hole depth in order to get the net depth. While drilling, use a cleaner to remove the dust.

If the surface is too smooth and solid to locate the drill bit, you can cut a concave with a punching bit to help position the drill bit.

When the $\Phi 14$ drill bit is selected but the hole diameter is small, enlarge the hole size through appropriate technical treatment.



Marking and drilling are the basic work of the equipment hardware installation. If they are inaccurate, it will cause great inconvenience to the later work. So their quality is the prerequisite to the whole project quality.

C. Install the expansion bolts

Before the installation, use a cleaner to clean the inside and outside of all the holes and then measure the space between holes. For holes with large deviation, it is necessary to reposition and re-drill the holes. Take out the gasket and nut of the expansion bolt, place the expansion rod and expansion bush vertically into the hole and hammer the expansion bolt with a rubber hammer until it goes fully into the ground.

1. 1. 1. 38 **Level the cabinet**

A. Place the cabinet in position

Place the cabinet in the planned position (note: The cabinet feet must be aligned with their position marks and the front/rear door positions of the cabinet should not be inversed. In the 2.2 m cabinet, the product label or nameplate is attached on the front door). Screw the nut at the root of the feet with a spanner so that the cabinet bottom face is 76 mm away from the floor and all cabinets are aligned with one another.

B. Level the cabinet

Place a horizontal ruler at the plane at the top of cabinet in two perpendicular directions, to check its horizontal level. Fine tune the cabinet feet so that the cabinet becomes level and then tighten the locking nuts of the cabinet feet.

1. 1. 1. 39 **Fix the cabinet**

A. Cabinet bottom fixation

Put back the pressure plate assembly in the sequence as shown in Figure 4-6, so that the pressure plate presses against the cabinet feet and use a torque wrench to fasten the bolt of the pressure plate assembly to 45Nm and thus fix the cabinet bottom. Figure 4-7 shows the effect after a single cabinet has been installed.

Figure 4-6 Installation sequence of the pressure plate assembly

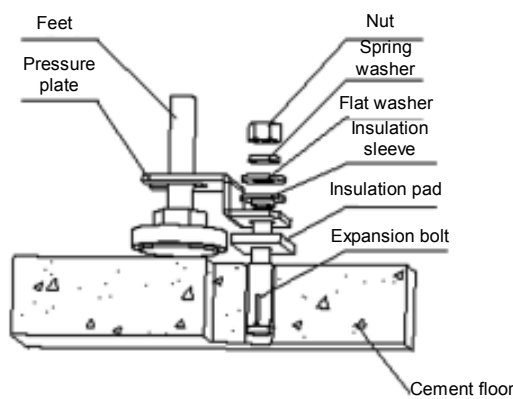
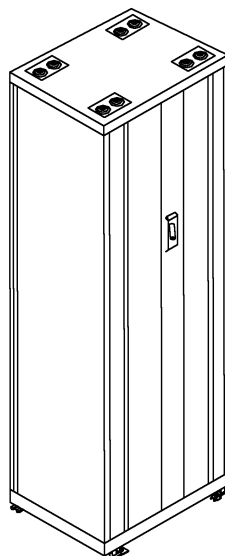

Figure 4-7 Completion of the installation of a single cabinet



Note

When multiple cabinets are to be combined, the following installation steps shall be also taken.

B. Cabinet top fixation

When two or more cabinets are combined, the inter-cabinet connection is needed (note that the cabinet side panels do not need to be dismantled during the connection of the two combined cabinets). Figure 4-8 shows the position of the inter-cabinet connecting board before the cabinets are combined. Release the inter-cabinet connecting board of the cabinet on the right and install it in the way as shown in Figure 4-9. The effect upon completion of installing the cabinet is shown in Figure 4-10.

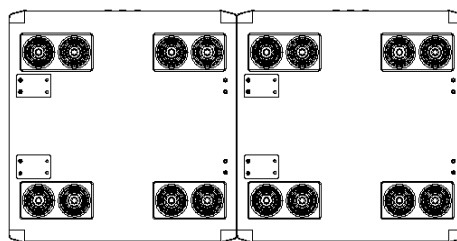
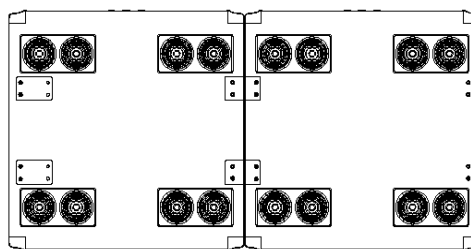
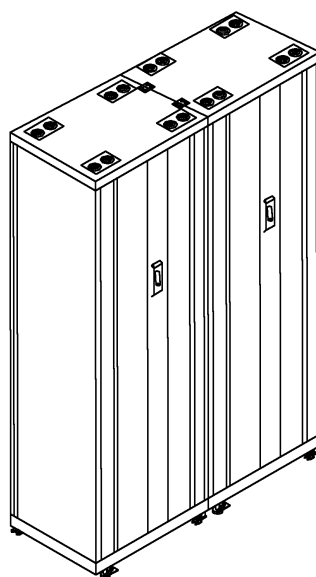
Figure 4-8 The connecting boards before combining two cabinets side by side**Figure 4-9 The connecting boards after combining two cabinets side by side****Figure 4-10 Effect after the installation of two combined cabinets**

1. 1. 1. 40 **Insulation test**

Set the multimeter to the resistor range to measure the resistance between the bolt of the pressure plate assembly and the cabinet. If the circuit is disconnected, end the installation. Otherwise, it indicates the cabinet is not insulated from the supports. In this case, remove all the pressure plate assemblies to check if any insulation sleeves or pads of the supports are missing or any insulation parts are damaged. Then install the pressure plate assemblies again and repeat the insulation test.

4.1.2. Installation on the Antistatic Floor

When the 19-inch cabinet 2.2 m high is installed on the antistatic floor of the equipment room, it shall use the A600 series supports. The cabinet is fixed by using pressure plates to press on the feet. Since the feet have the insulating function and the pressure plate assembly contains insulating parts, the whole equipment is insulated from the earth before the grounding cable is connected and the insulating requirements can be effectively satisfied.

The purpose of the supports is to support the cabinet and facilitate the floorboard layout and cabling of the equipment. Each support is welded from steel plates and its installation shall be in the mode of floor brackets, that is, the floor is located between the cabinet and the supports and bolts thread through the antistatic floor to fix the cabinet with the supports, thus achieving the purpose of cabinet fixation and support.

Figure 4-11 Appearance of the A600 series support

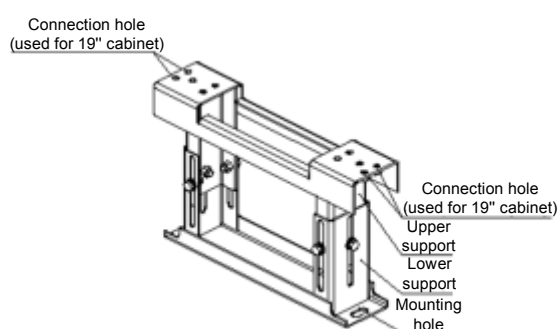

There are four components of the A600 series support: Three with adjustable height and one with fixed height. The applicable height of the antistatic floor is from 260 mm to 410 mm.



prompt

The height of ESD protection floor refers to the distance from the upper plane of the floor to the surface of the cement floor. The A600 series support components can implement steeples adjustment within their adjustable ranges by means of the relative movement of the upper and lower supports.

Each 19-inch cabinet uses two supports. Figure 4-12 shows the completed installation of a single cabinet on the antistatic floor:

Figure 4-12 Completion of the installation of a single cabinet

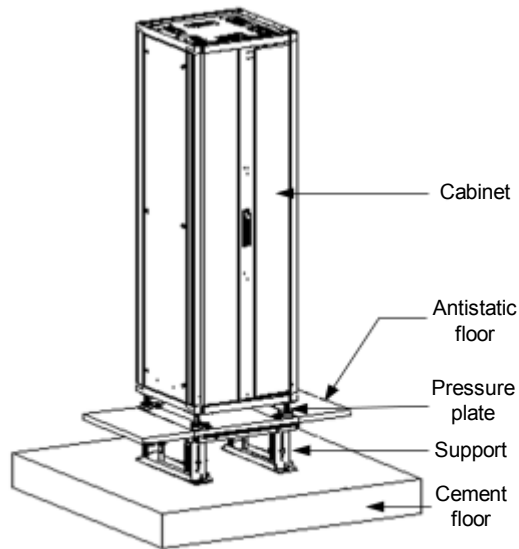

See Figure 4-13 for the installation flow.

Figure 4-13 Flow of the cabinet installation on the antistatic floor

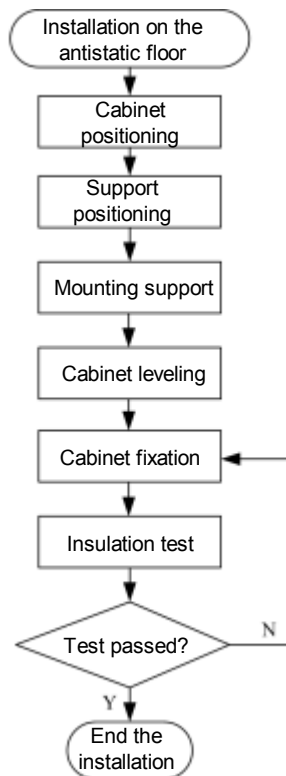

1. 1. 1. 41 **Position the cabinet**

A. Determine the cabinet installation position

The position of the cabinet should be determined according to the benchmark sizes specified in the floor design of the equipment room. In determining the installation positions, avoid interference between the mounting support and the skeleton of the antistatic floor, i.e., try to keep the integrity of the floor skeleton. If such interference is inevitable, remove the skeleton of the floor board where the interference occurs. It is recommended that the center of the cabinet coincide with the center of the floorboard and all sides of the cabinet shall be symmetrical to the central symmetric line of the antistatic floor board. If multiple cabinets are to be installed side by side, the first cabinet should be arranged in this way.

B. Marking

Place the marking template of the cabinet (placed in the packing wooden box of the cabinet) on the antistatic floor according to the cabinet arrangement. The cabinet marking template is illustrated in Figure 4-14. Mark all the cabinet connection holes (four per cabinet) on the floor according to the marking template diagram, the feet position marks (four feet per cabinet) and the cabling hole positions. The semicircle gap of the template indicates the front direction of the rack. Mark the positioning and mounting holes of the supports on the cement floor.

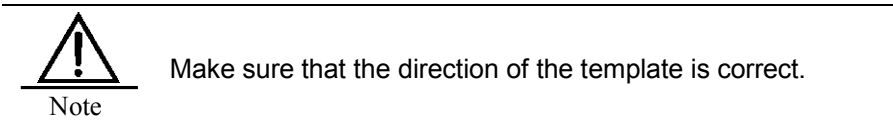
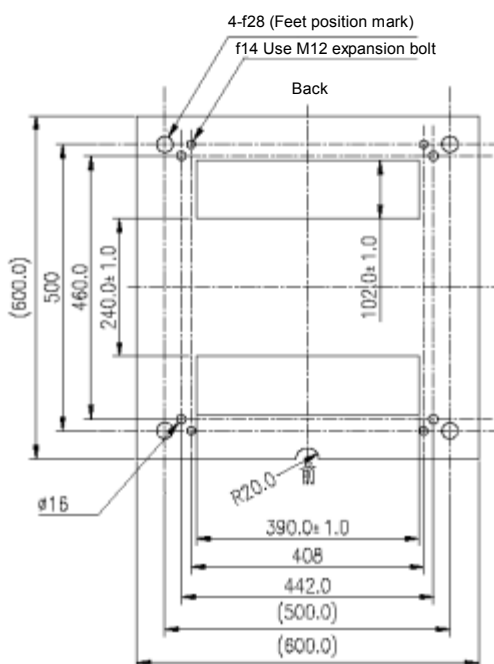

Figure 4-14 Cabinet marking template



C. Drill holes in the anti-static floor

Remove the marking template and drill a through-hole at each connection hole position on the antistatic floor using a percussion drill with the $\Phi 20$ drill bit. To drill a hole, keep the drill bit vertical with the antistatic floor and hold tightly the drill handle and do not shake, lest the hole be slanted.



Note

Marking and drilling are the basic work of the equipment hardware installation. If they are inaccurate, it will cause great inconvenience to the later work. So their quality is the prerequisite to the whole project quality.

D. Cut out the holes

Cut out the through-holes with an electric saw on the antistatic floor according to the cabling hole marks.

1. 1. 1. 42 Position the supports

A. Mark lines on the cement floor

Place the supports beneath the antistatic floor and align the connection holes on the supports to the holes on the antistatic floor. With the support mounting holes as the template, make the position marks of the expansion bolts on the floor.



Note

Strictly obey the method shown in Figure 4-15 to install the supports and make sure the connection holes at the inner side of the supports are aligned with the holes on the floor while preventing the supports from shielding the cabling holes as much as possible.

Figure 4-15 Connection positions of the mounting holes for the support and the antistatic floor

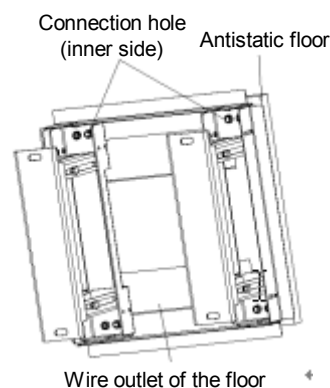

B. Drill holes in the cement floor

The support is fixed to the floor by means of expansion bolt M12. Normally a percussion drill is used to drill holes and the $\Phi 14$ or $\Phi 16$ drill bit is selected. To drill a hole, keep the drill bit vertical with the surface and hold tightly the drill handle and do not shake, lest the surface be damaged and the hole be slanted. The depth of the hole should be the length of the expansion bush plus the cone. All holes must be consistent in the depth. Remove the dust out of the hole while measuring the hole depth in order to get the net depth. While drilling, use a cleaner to remove the dust.

1. 1. 1. 43 Install the supports

A. Install the expansion bolts

Before installation, use a vacuum cleaner to remove the dust inside and outside all the hole positions and then measure the distance between the holes. Place the supports inside the holes to see whether the holes match them. Do not mount the expansion bolt with large deviation to the holes. Instead, locate and drill the holes again. Take out the gasket and nut of the expansion bolt, place the expansion rod and expansion bush vertically into the hole and hammer the expansion bolt with a rubber hammer until it goes fully into the ground.

B. Adjust the supports

Roughly adjust the supports to their predefined height and fine tune the height-locking bolt of each support till the upper support will not automatically slip. Place the supports at their installation positions and thread the expansion bolts through the mounting holes on the supports.

C. Fix the supports

Align the holes on the antistatic floor with the connection holes on the support, screw in the bolts M12×70 from the top down, and place the pressure plate assemblies in the method shown in Figure 4-16. Slightly knock the supports with a rubber hammer and fine tune their height. Make the antistatic floorboard fall on the skeleton of the floor according to its original position and ensure that the upper surface of the supports is closely pressed against the antistatic floorboard. Then use a torque wrench to fasten the bolt of the pressure plate assembly, the expansion bolt and the height-locking bolt of the support all to 45Nm. In this process, fasten the bolts in the middle first before fastening the bolts at the two sides. Figure 4-17 shows the fastening of the bolts.

Figure 4-16 Assembly chart of the pressure plate assembly

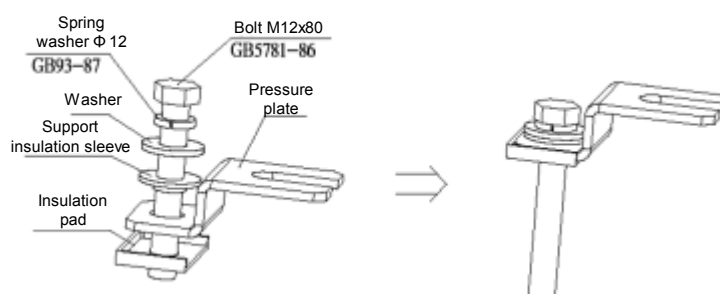

Note

The above procedure shall be strictly obeyed to fasten the above three groups of bolts.

Figure 4-17 Positions of the bolts to be fastened

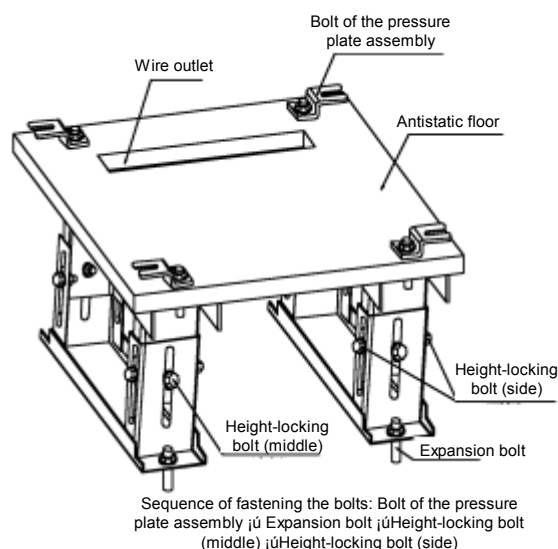

1. 1. 1. 44 Fix the cabinet

A. Level the cabinet

Restore all the antistatic floorboards to their original state. Loosen all the bolts on the pressure plate assemblies and remove the pressure plate assemblies. Push the cabinet to the predefined position (the cabinet feet must coincide with their position marks) and screw the four feet with a spanner, so that the bottom surface of the cabinet is 73 mm away from the floor and all cabinets are aligned. Place a horizontal ruler at the plane at the top of cabinet in two perpendicular directions, to check its horizontal level. Fine tune the cabinet feet so that the cabinet becomes level and then tighten the locking nuts of the cabinet feet.

B. Fix the cabinet

Put back the pressure plate assembly again, so that the pressure plate presses against the cabinet feet and use a torque wrench to fasten the pressure plate assembly bolt to 45 Nm.



Note

Please skip Step C below to install a single cabinet.

C. Cabinet top fixation

When two (or more) cabinets are combined, it is necessary to connect the combined cabinets. Figure 4-8 shows the position of the inter-cabinet connecting board before the cabinets are combined. Release the inter-cabinet connecting board of the cabinet on the right and install it in the way as shown in Figure 4-9. Figure 4-18 shows the effect after two cabinets are combined.

Figure 4-18 Completion of the installation of two combined cabinets

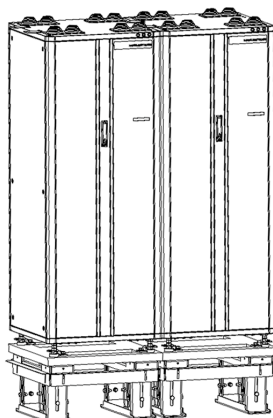

1. 1. 1. 45 **Insulation test**

Set the multimeter to the resistor range to measure the resistance between the bolt of the pressure plate assembly and the cabinet. If the circuit is disconnected, end the installation. Otherwise, it indicates the cabinet is not insulated from the supports. In this case, remove all the pressure plate assemblies to check if any insulation sleeves or pads of the supports are missing or any insulation parts are damaged. Then install the pressure plate assemblies again and repeat the insulation test.

4.1.3. Installing the Cabinet Guide Rails

Before installing the equipment, install the guide rails first inside the cabinet to bear the equipment. The installation steps are as follows:

Step 1 Determine the installation positions of guide rails.

Determine the installation positions of the guide rails according to the quantity of the chassis to be installed, and the cabling direction. Measure the installation positions and mark them.



prompt

Guide rails are needed to install the 10U chassis and the fan module, but not needed for the air deflector frame (it only needs hangers to get fixed).

Step 2 Install the guide rails.

After determining the installation positions, fasten the guide rails at such positions inside the cabinet with screws, as shown in Figure 4-19.

Figure 4-19 Guide rail

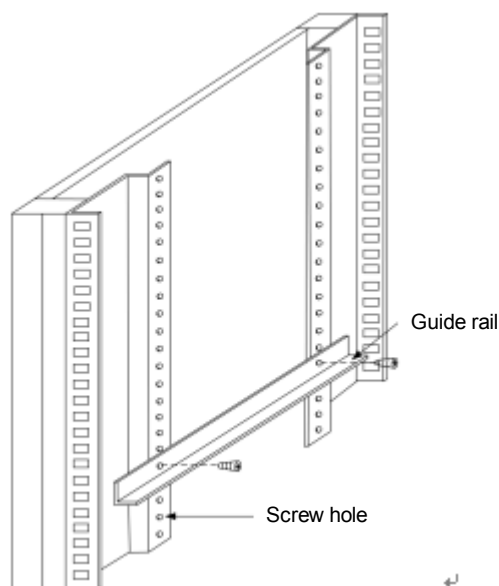

The front view of the installed guide rails is illustrated in the following figure.

Figure 4-20 Front view of the guide rails installed

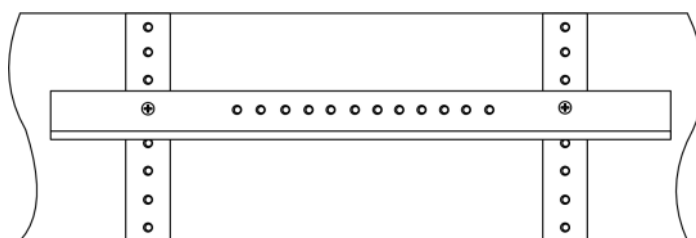

4.2. Installing the Equipment

3P@C 4450E must be installed in a cabinet. Since it is heavy and of a large volume, two persons are needed to cooperate with each other in the installation process. To install it, first install the 10U chassis, then the fan module and finally the air deflector frame. The specific procedure is as follows:

4.2.1. Installing the 10U Chassis



prompt

If the 10U chassis has been mounted with hangers, you can skip Step 1 and start the installation directly from Step 2.

Step 1

Mount the hangers with screws provided in the installation accessories onto the 10U chassis, as shown in the following figure. In the process, make sure the hangers are mounted in the correct direction; otherwise the switch would not be able to be placed in the standard cabinet.

Figure 4-21 Fixing the hangers onto the 10U chassis

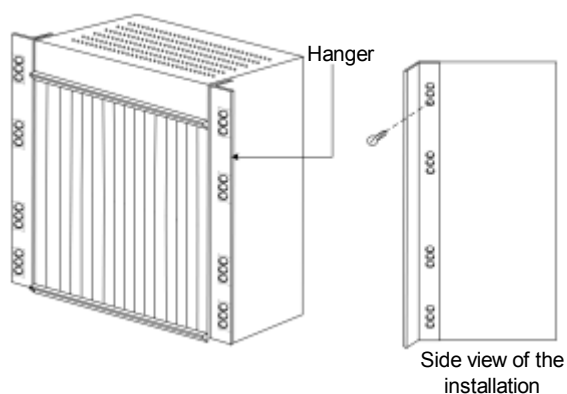

Step 2	Hold the two edges of the 10U chassis and slowly slide it inward from the front face of the rack, till the hangers bit the rack.
Step 3	Align the screw holes on the front face of the hangers with the screws on the rack and fasten them with screws to ensure the stability of the equipment, as shown in Figure 4-22.

Figure 4-22 Insert the 10U chassis into the rack and fix it

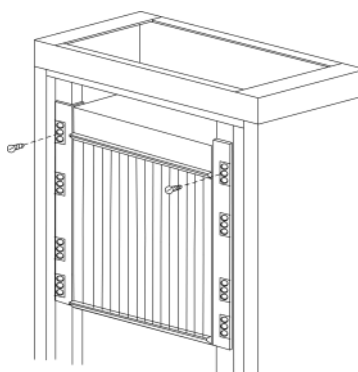

4.2.2. Installing the Fan Module

The fan module should be installed below the 10U chassis in the following steps:

Step 1	Install the fan support and connect the hangers at the two sides of the fan support with screws, as shown in the following figure.
--------	--

Figure 4-23 Install the fan supports

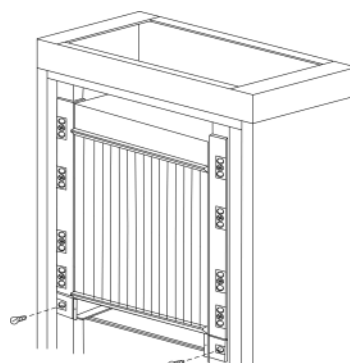

Step 2	Install the fan module. Insert the fan module into the fan support and tighten the captive screws on the two sides after the fan module is in position, as shown in Figure 4-24.
--------	--

Figure 4-24 Install the fan module

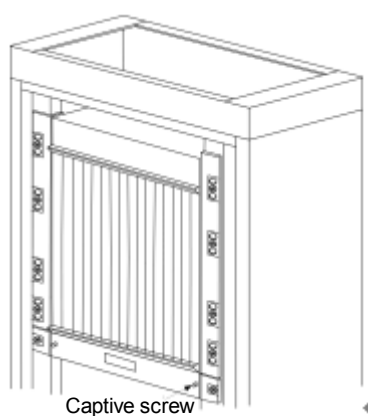

prompt

Generally, the fan module delivered has already been mounted with hangers. If not, you can install the hangers first according to Step 1 above for the installation of the 10U chassis.

The fan module contains six DC fans that weigh about 3 kg. To make the replacement and cleaning of the fans much easier, the fan module of 3P@C 4450E is designed to be dismountable. As shown in Figure 4-25, a puller adapter is designed in the front face of the fan module. This puller adapter is closed when not in use. When it is needed to dismount, replace or clean the fans, please operate this puller adapter with both hands.

Step 1	Wear the antistatic wrist strap and insert its plug into the ESD socket in the front face of the 19-inch cabinet 2.2 m high.
Step 2	Cut off the system power supply of 3P@C 4450E before inspecting the fan module for a long while (more than 5 minutes).
Step 3	Loosen the fastening screws at the two sides of the fan module with a screwdriver.
Step 4	Press down the white left end of the puller adapter in the middle of the fan module panel. The puller adapter will automatically eject out, as shown in Figure 4-25.

Figure 4-25 Operate the puller adapter

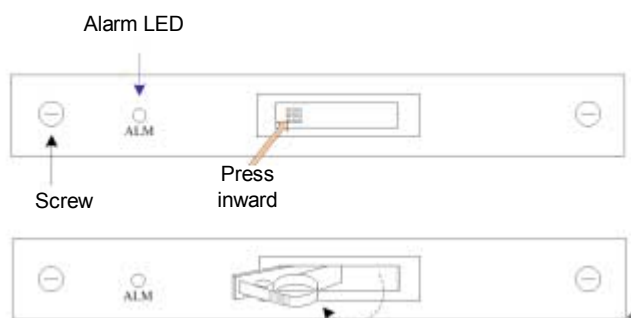

Step 5	Drag the puller adapter to pull out the fan module by 10 cm from the chassis so that the fan module is detached from the internal power socket of the chassis.
Step 6	Wait for a minute till the fans fully stop running if you dismount the fan module without disconnecting the power supply.
Step 7	Hold the puller adapter of the fan module with the right hand, and fully pull out the fan module from the chassis with the left hand holding the bottom of the fan module.
Step 8	Place the removed fan module at a safe place.



Note

If you replace the fan module without cutting off its power on site, please install a new fan module as soon as possible after dismounting the fan module. Prepare the new fan module in advance and put it away in a safe place on site.

4.2.3. Installing the Air Deflector Frame



Note

The air deflector frame should be installed tightly against the bottom of the fan module. It is forbidden to reserve unnecessary space between the air deflector frame and the bottom of the fan module.

Method: Insert the air deflector frame tightly against the bottom of the fan module into the cabinet, and connect the hangers at the two sides of the air deflector frame with the cabinet by using screws, as shown in Figure 4-26.

Figure 4-26 Install the air deflector frame

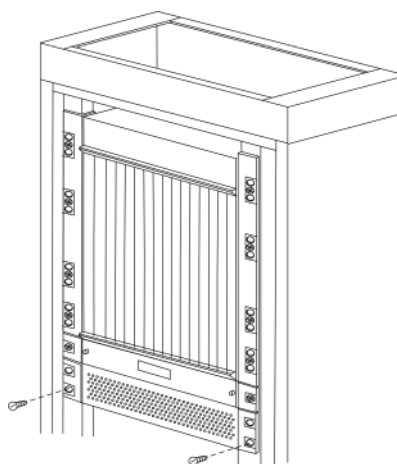

prompt

Generally, the air deflector frame delivered has already been mounted with hangers. If not, you can install the hangers first according to Step 1 above for the installation of the 10U chassis.

Till now, a general chassis of 3P@C 4450E has been installed. Figure 4-27 shows the front view of the 3P@C 4450E switch installed in the cabinet.

Figure 4-27 Completion of the installation of a single general chassis

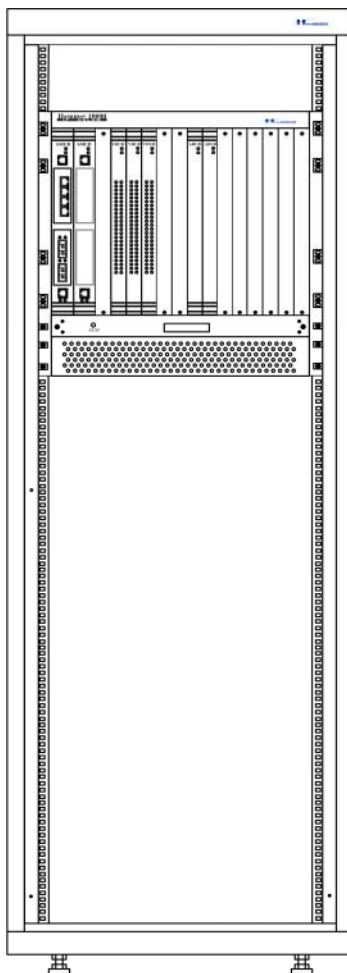

Next, repeat the above operations to install multiple general chassis of 3P@C 4450E in the cabinet.



prompt

1. When installing multiple general chassis of 3P@C 4450E in the cabinet, the installation of the first one in the cabinet can start from the top installation position or the bottom one of the cabinet.
2. If upward cabling is adopted on site, the cabling should be arranged from the bottom up from the bottommost general chassis in the cabinet. Otherwise, the cabling should be arranged from the top down from the topmost general chassis in the cabinet.

4.3. Connecting the Power and Grounding Cables

4.3.1. Connecting the Power Cables of the Equipment

The –48V DC power cables should be connected to the output control end and the wiring terminals on the cabinet. Its installation is shown in the following figure.

Figure 4-28 Installation of the -48V DC power cables

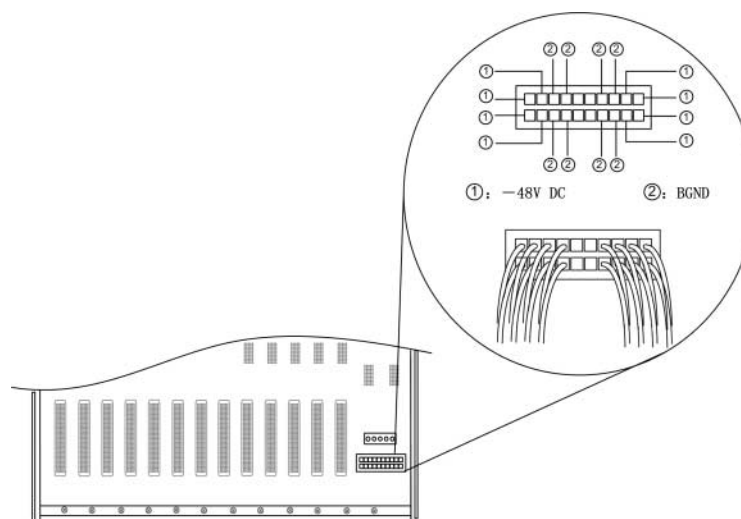

Cabling requirements for the DC power cable are given as follows:

- First connect the power supply system to the power input cable of the cabinet, and then connect the power distribution system to the output power cable of the equipment power supply.
- In the upward cabling of the system, the output branches shall be arranged from the top down.
- In the downward cabling of the system, the output branches shall be arranged from the bottom up.
- The cables inside the cabinet shall not cross one another and they shall be sorted in order with different colors of the cables bound into different bundles.
- The surplus of the cables should be appropriate and the excessive cables should be cut away and re-processed rather than staying at the cabinet bottom or on the cabinet.
- The power cables should be connected to the output control end and the wiring terminals on the cabinet with both ends of such cables attached with labels 5 cm away from the cable root.
- After connecting the power cables, tighten all the screws (U screws) for fixing the cables at the back of the cabinet. No loose screw is allowed.
- In the processing of copper lugs, first crimp them, then solder them and finally put on the heat shrinkable tubing.
- Select the appropriate models of cable ties to bind the cables. The cable ties should fact the same direction and should be cut flat without sharp ends.
- The power cables should preferably installed from the wiring terminal of the first control switch.

To connect the 220 V AC power supply, it is necessary to use the primary power supply system. Before connecting the power supply, check the power supply specifications carefully and ensure the correct power supply is connected so as to avoid any damage to the equipment. Furthermore, ensure that the power of the primary power system is no less than the power of the 3P@C 4450E switch in its full load, lest the power supply system be burned. Generally, the full-load power of the 3P@C 4450E switch shall be 60% ~ 70% of the power capacity of the primary power supply system.

4.3.2. Connecting the Power Cable of the Fans

The power cable connection of the fans is shown in the following figure.

Figure 4-29 Power cable connection of the fans

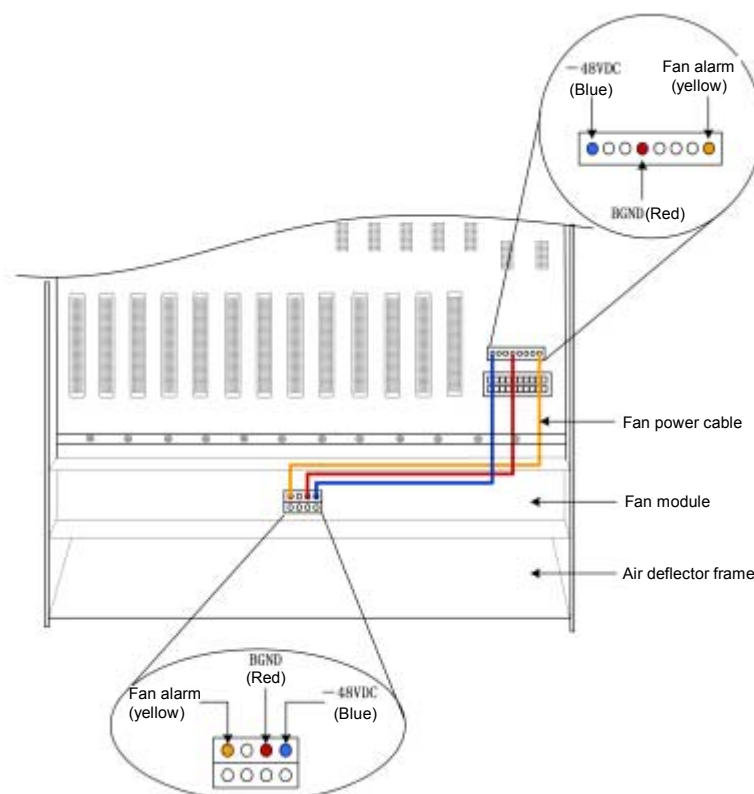

After connecting the power cable of the fans, connect –48V DC power before trial run. The installation of the –48V DC power cable is shown in Figure 4-28.

4.3.3. Connecting the Grounding Cables

1. 1. 1. 46 Grounding cable connection of the equipment

To ensure the safe equipment operation, make sure the equipment is well grounded. Connect the grounding point of the equipment and the PGND connection point of the DC distribution unit on the rack to ensure reliable grounding. At the same, connect the PGND of the DC distribution unit to the grounding point in the equipment room reliably with a grounding cable whose cross-sectional area is no less than 16mm² to ensure reliable grounding of the rack. If the rack is poorly grounded, separate grounding protection measures should be taken for the equipment as follows: Take a wire, and connect one of its end to the grounding bolt on the equipment rear and the other end to the grounding terminal in the equipment room.

1. 1. 1. 47 Grounding cable connection of the power supply

The rack provides a grounding bolt “PGND”. PGND (protection ground) is the cabinet shell ground (earth). Connect the “PGND” wiring terminal on the cabinet to the “PGND” busbar of the DC distribution unit with a yellow-green power cable.

4.3.4. Equipment Power Supply Test

To ensure correct power supply for the equipment, it is necessary to try powering on the equipment with zero load and check if the fans work normally. If the fans work normally, cut the -48 V power, and proceed with the installation steps. When all the SMUBs and service boards are installed, power on the equipment again. Otherwise, repeatedly check whether the fan power and the -48 V DC power are correctly connected.

4.4. Installing the Service Processor Unit Board (SMUB)

The SMUB is used to implement the higher layer protocol processing and equipment management functions. It needs to communicate with the uplink data through the interface module. Since it does not contain any interface module or routing module, you may select these modules as required and install them on the SMUB.



Note

Before any operation, you must release the static electricity on your body. It is suggested to wear the antistatic wrist strap.

4.4.1. Installing the Uplink Interface Modules

Each SMUB can be installed with 2 uplink interface modules. To implement the interworking between the 3P@C 4450E and the other networks, at least one uplink interface module should be installed. There are 4 screw holes on the SMUB corresponding to the installation position of an uplink interface module. They are used to fix the module, as shown in the following figure:

Figure 4-30 Panel view of the SUMB

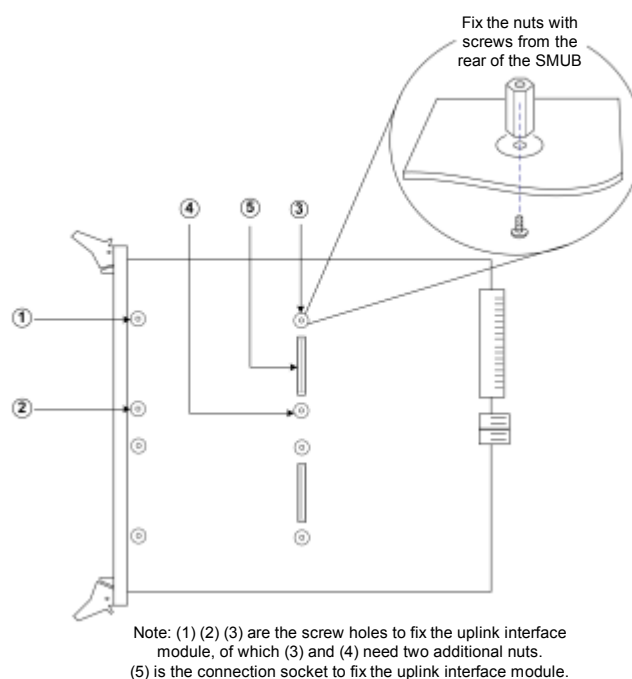

To install the uplink interface module, take the following steps:

Step 1	Place the SMUB on a flat and stable insulating desktop, and remove the baffle plate in the position of the uplink interface.
Step 2	Take out the purchased uplink interface module from the packing box, fix two fixation copper bars and an interface board panel to the interface module with screws, insert the uplink interface of the uplink interface module into the uplink interface of the SMUB, align the pins of the interface module with the SMUB socket, and then push the pins into the socket with even force, as shown in Figure 4-31. Now the screw holes on the four corners of the interface board are aligned with the four screw holes on the SMUB. Get ready to install the screws.

Figure 4-31 Insert the pins of the uplink interface module into the socket of the SMUB

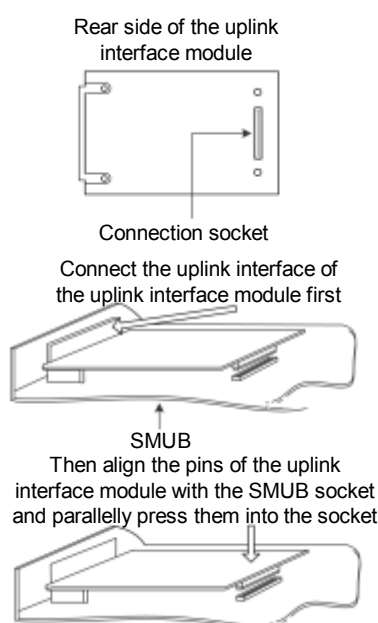

Note

You should hold the edges of the module instead of touching the component or the printed circuits to avoid damage to the component caused by human static electricity.

Step 3	Fix the module with the special-purpose screws used to install the uplink interface module, as shown in Figure 4-32.
--------	--

Figure 4-32 Fix the uplink interface module with screws

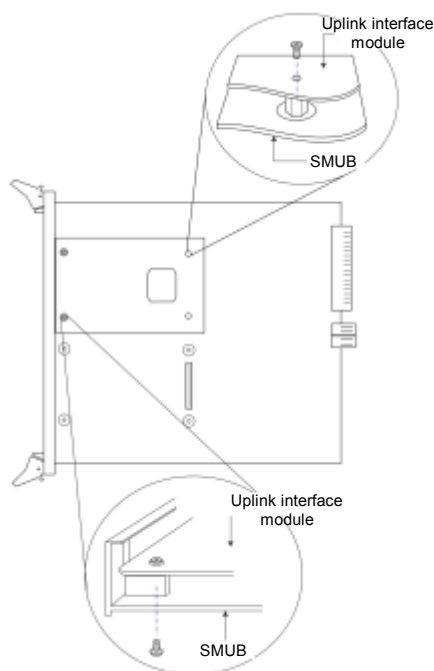

By now, the uplink interface module is installed.

The method for removing the uplink interface module is similar to the installation method. Only the procedure is reverse.

4.4.2. Installing the RTU

Each SMUB can be installed with an optional RTU module (please refer to Section 2.6 for the selection of RTU). The RTU does not provide any external interface. It only provides the L3 routing and flow table functions for the SMUB. There are 4 screw holes and a connection socket on the SMUB corresponding to the installation position of the RTU, as shown in Figure 4-33:

Figure 4-33 Installation position of the RTU

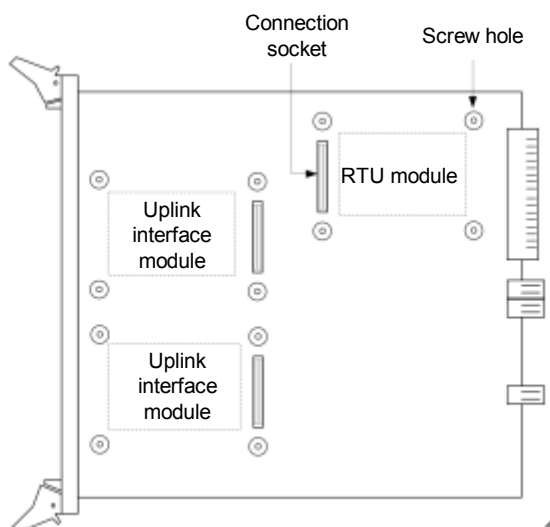

To install the RTU, take the following steps:

Step 1	Place the SMUB on a flat and stable insulating desktop.
Step 2	Take out the purchased RTU module from the packing box, align the pins of the RTU with the SMUB socket, and then push the pins into the socket with even force, as shown in Figure 4-34. Now the screw holes on the four corners of the RTU are aligned with the four screw holes on the SMUB. Get ready to install the screws.

Figure 4-34 Insert the pins of the RTU into the socket of the SMUB

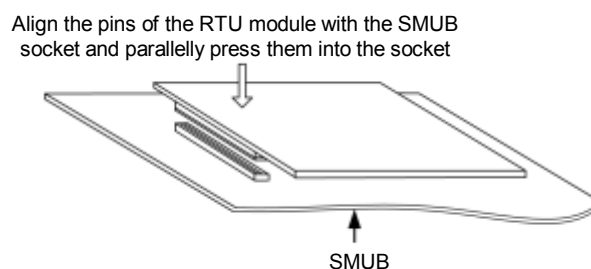

Note

You should hold the edges of the module instead of touching the component or the printed circuits to avoid damage to the component caused by human static electricity.

Step 3	Fix the module from the rear of the SMUB with the special-purpose screws used to install the RTU, as shown in Figure 4-35.
--------	--

Figure 4-35 Fix the RTU with screws

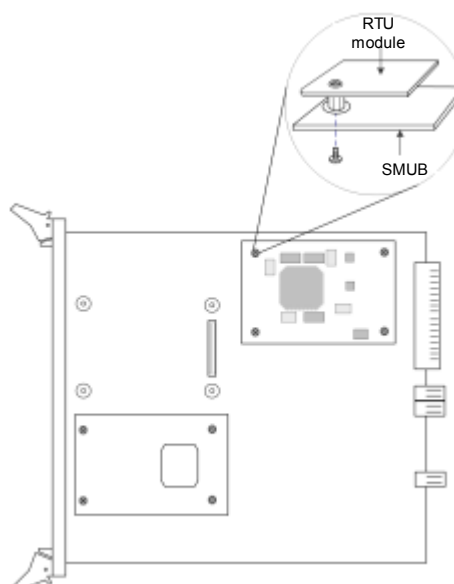

By now, the RTU module is installed.

The method for removing the RTU is similar to the installation method. Only the procedure is reverse.



prompt

Generally, the screws and nuts have been installed on the four corners of the purchased RTU module, as shown in Figure 4-36. If no screw or nut is installed on the four corners of the purchased RTU module, then you should first install the screws and nuts, and then install the RTU on the SMUB.

Figure 4-36 Rear view of the RTU installed with screws and nuts

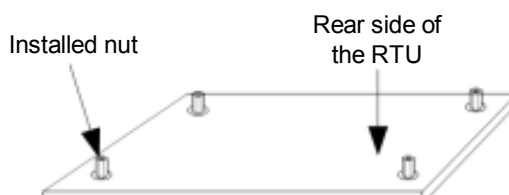

4. 4. 3. Installing the SMUB

Before installing the SMUB, you should first install the uplink interface module and the RTU (optional).

To install the SMUB, take the following steps:

Step 1	Cut off the power supply before the installation.
Step 2	Make sure that 3P@C 4450E is well grounded and the operator wears an antistatic wrist strap.
Step 3	Remove the dummy panel installed in the slot of the SMUB by removing the screws.
Step 4	Take out the SMUB, align it with the slot, press the two puller adapters outward with both hands, and push the SMUB along the guide rail into the slot with even force till the SMUB touches the connection socket on the backplane.
Step 5	Press the two puller adapters of the SMUB inward with both hands to plug the SMUB into the connection socket on the backplane. Now the two puller adapters are reset automatically. Tighten the two screws on the puller adapters to fix the SMUB.

Figure 4-37 Installation of the SMUB

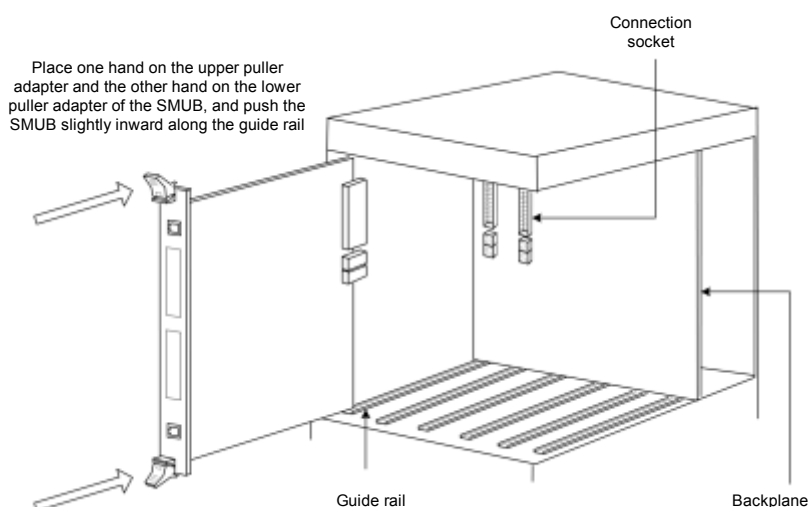

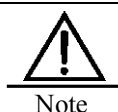

Note

Although 3P@C 4450E supports hot plugging, to prolong the life span of the equipment and the modules, try not to plug/unplug the equipment or the modules with power on.

4.4.4. Connecting the Ethernet Interfaces of SMUB

The SMUB of 3P@C 4450E has an RJ-45 Ethernet interface (10/100Base-TX interface). In addition, the uplink interface sockets on the SMUB can be installed with the uplink interface module DS-4TXB/DS-4ITX which provides 4 RJ-45 Ethernet interfaces. The RJ-45 network interface provided by 3P@C 4450E has the interface polarity automatic calibration function. It can be connected to the other network devices by the C5 UTP (Unshielded Twisted Pair) or STP (Shielded Twisted Pair).

1. 1. 1. 48 RJ-45 connector

Figure 4-38 RJ-45 connector

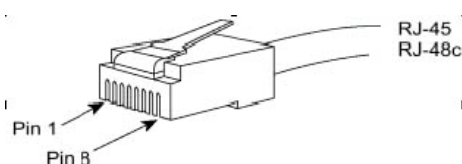

Figure 4-38 shows the appearance of the RJ-45 connector and arrange of pins. Table 4-1 show the functions of the RJ-45 connector pins in MDI mode, while Table 4-2 shows the functions of the RJ-45 connector pins in the MDIX mode.

Table 4-1 Pinouts of the RJ-45 MDI interface

Pin No.	Signal	Function
1	TxData+	Transmit data
2	TxData-	Transmit data
3	RxData+	Receive data
4	Reserved	
5	Reserved	
6	RxData-	Receive data
7	Reserved	
8	Reserved	

Table 4-2 Pinouts of the RJ-45 MDIX interface

Pin No.	Signal	Function
1	RxData+	Receive data
2	RxData-	Receive data
3	TxData+	Transmit data
4	Reserved	
5	Reserved	
6	TxData-	Transmit data
7	Reserved	
8	Reserved	

1. 1. 1. 49 **Preparing the network cables**

A Category 5 twisted pair is made up of 8-core thin wires. They are identified into groups by the color of the external insulation layer of the thin wires. In general, a single color and a single color plus white are used to identify a twisted pair, or color dots are sometimes used for paired identification. According to this method of identification, the eight-core thin wires of a Category 5 twisted pair can be divided into four pairs: Orange & orange/white, blue & blue/white, green & green/white, brown & brown/white.

Usually there are two kinds of Ethernet cables connecting the two Ethernet devices: Straight-through cable and crossover cable. Figures 4-39 and 4-40 show respectively the connection methods of a straight-through cable and a crossover cable. Selection shall be based on the application requirements. In the figures, "SIDE1" and "SIDE2" indicate the two ends of the network cable respectively while numbers "1 ~ -8" represents the line sequence at the two ends.

Figure 4-39 Illustration of making a straight-through cable

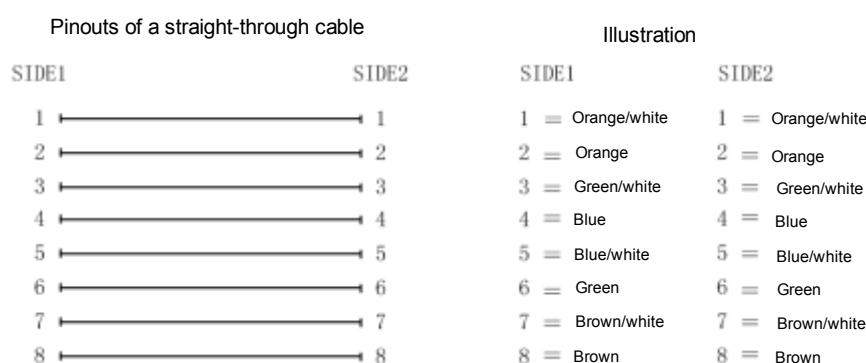
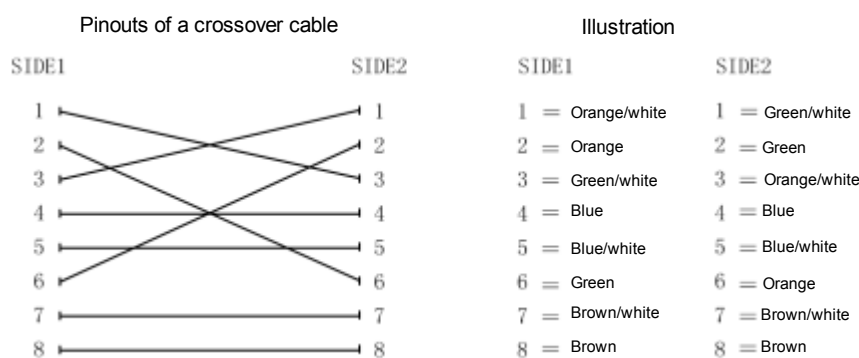

Figure 4-40 Illustration of making a crossover cable



1. 1. 1. 50 **Ethernet interface connection**

Connect one end of the twisted pair that uses RJ-45 connectors at both ends to the Ethernet interface of the SMUB, and the other end to the Ethernet interface of the other Ethernet-compatible device in the LAN, as shown in Figure 4-41:

Figure 4-41 Ethernet interface connection of the SMUB

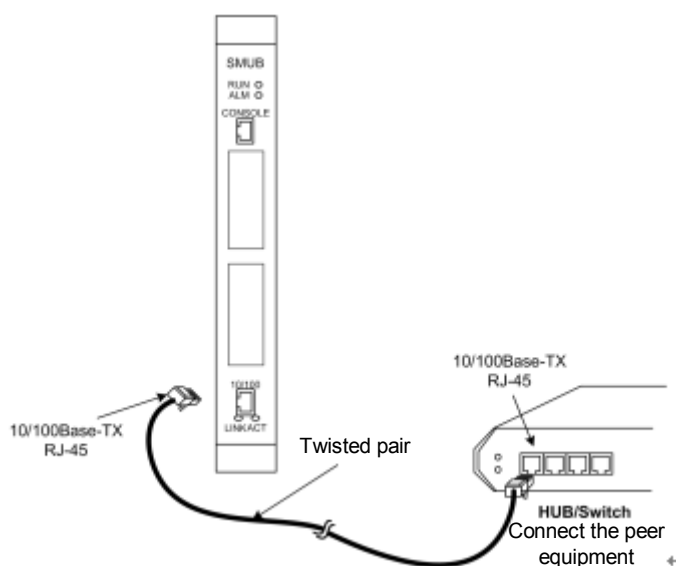

4.4.5. Connecting the Optical Interfaces of SMUB

The SMUB of 3P@C 4450E supports the 100M/1000M uplink optical interface module and the ATM uplink optical interface module. The standard SC fiber connectors shown in Figure 4-42 are adopted for these optical interfaces.

Figure 4-42 SC optical connector

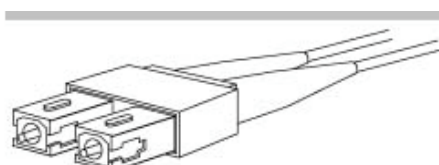

When connecting an optical interface, note that the fiber specifications must be consistent with the features of the uplink optical interface. For example, if the optical interface is a multi-mode interface, the multi-mode fiber should be used. And when the optical interface is a single-mode interface, the single-mode fiber should be used. Also you should make clear the transceiving polarity of the optical fiber interface. The 3P@C 4450E uses standard SC fiber connectors. During the optical interface connection, the fiber with SC connectors at both ends should be used. If one end of the fiber connects with the Rx-Tx interface of the uplink optical interface of the 3P@C 4450E switch, then the other end should be connected to the Tx-Rx optical interface of the peer equipment. That is, the Rx interface of the uplink optical interface corresponds to the Tx optical interface of the peer switch, while the Tx interface of the uplink optical interface corresponds to the Rx optical interface of the peer switch.

Figure 4-43 shows the connection of the uplink optical interface of 3P@C 4450E:

Figure 4-43 Uplink optical interface connection

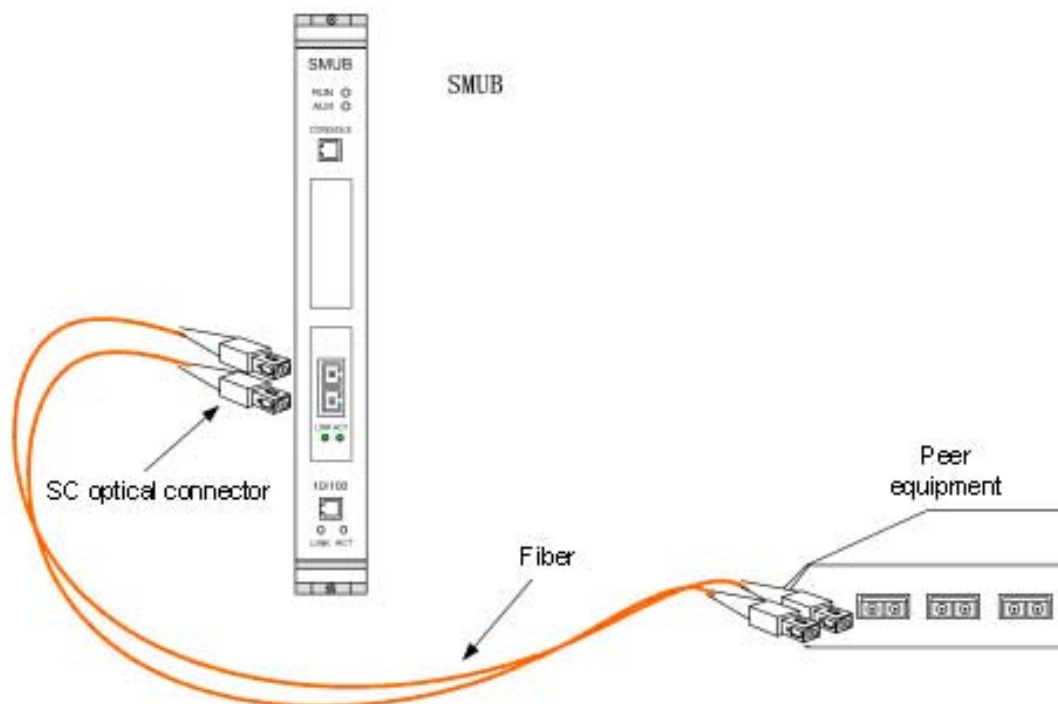

prompt

For the descriptions of fibers, please refer to the contents in Appendix C.

4.5. Installing the Subscriber Service Cards

The method and procedure for installing the ADUB/ADUC/VDUB are the same as those of the SMUB. Please refer to Section 4.4.3.

4.6. Installing the Dummy Panels

Dummy panels should be installed in the slots where no subscriber service boards or SMUBs are inserted so as to keep the integrity of the air duct of the 10U chassis, ensure the reliable heat dissipation of the system and the good electromagnetic compatibility of the equipment, and meet the dustproof requirements.

To install a dummy panel, take the following steps:

Step 1	Take out a dummy panel, hold both ends of it with both hands, and place it in an empty slot.
Step 2	Press the dummy panel with one hand, and insert screws in the holes on the dummy panel with the other hand.
Step 3	Tighten the screws to end the installation.

The installation is shown in the following figure:

3P@C Installation Manual

Figure 4-44 Install a dummy panel

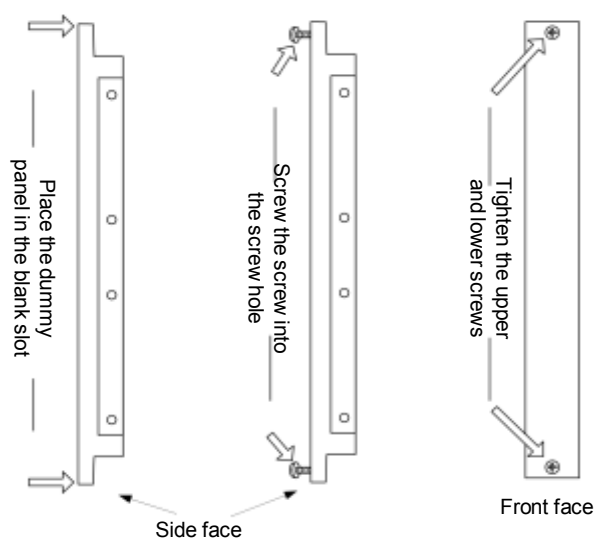

prompt

The width of the dummy panel in the slot of the SMUB is greater than the width of the dummy panel in the slot of the subscriber service board. The dummy panel in the slot of the subscriber service board is fixed by 2 screws, while that in the slot of the SMUB is fixed by 4 screws.

4.7. Connecting the Subscriber Cables

The rear leading-out mode is adopted for the ADSL/VDSL subscriber cables of 3P@C 4450E. The special-purpose 3*8 cable connectors are used to connect with the DIN connectors on the rear panel. The subscriber cables are divided into two types: LU connection subscriber cables and LC connection telephone switch cables. The connector of the LU subscriber cable has 3 marks: UP X1, UP X2 and UP X3, which are connected on the DIN connector on the backplane from the top down in the sequence of UP X1, UP X2 and UP X3. The connector of the LC telephone switch cable has 3 marks: DOWN X1, DOWN X2 and DOWN X3, which are connected to the DIN connectors in the lower row on the backplane from the top down in the sequence of DOWN X3, DOWN X2 and DOWN X1. LU and LC subscriber cables are installed on the DIN connectors on the backplane (as shown in Figure 4-45). The pinouts of the LU subscriber cable are shown in Figure 4-46 and Table 4-3, while the pinouts of the LC telephone switch cable are shown in Figure 4-47 and Table 4-4.



prompt

The connector of the LU subscriber cable is plugged from the upper part of the connector in the upper row, while the connector of the LC subscriber cable is plugged from the lower part of the connector in the lower row.

Figure 4-45 Installation of the LU and LC subscriber cables on the backplane

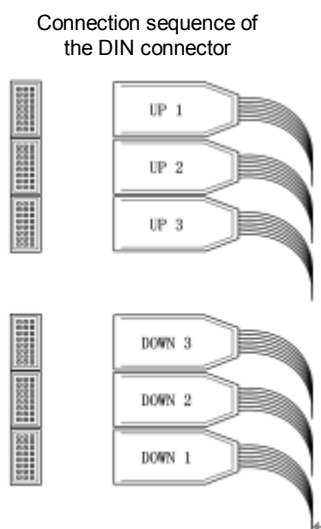

Figure 4-46 Pinouts of the LU subscriber cable

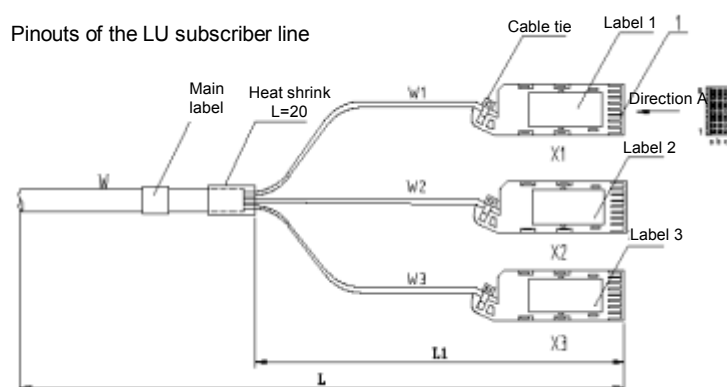

Table 4-3 Pinouts of the LU subscriber cable

Connector X1				Connector X2			
Connector X1	Color	Identification	Subscriber No.	Connector X2	Color	Identification	Subscriber No.
C1	Pink	Red*	1	C1	Green	Red***	13
C2		Black**		C2		Black***	
B1	Orange	Red*	2	B1	Blue	Red***	14
B2		Black**		B2		Black***	
A1	Green	Red*	3	A1	Grey	Red***	15
A2		Black**		A2		Black***	
C3	Blue	Red*	4	C3	Pink	Red****	16
C4		Black**		C4		Black	
B3	Grey	Red*	5	B3	Orange	Red****	17
B4		Black**		B4		Black	
A3	Pink	Red***	6	A3	Green	Red****	18
A4		Black**		A4		Black	
C5	Orange	Red***	7	C5	Blue	Red****	19

C6		Black**		C6		Black		
B5	Green	Red***	8	B5	Grey	Red****	20	
B6		Black**		B6		Black		
A5	Blue	Red***	9	A5	Pink	Red* (full)	21	
A6		Black**		A6		Black* (full)		
C7	Grey	Red***	10	C7	Orange	Red* (full)	22	
C8		Black**		C8		Black* (full)		
B7	Pink	Red***	11	B7	Green	Red* (full)	23	
B8		Black** *		B8		Black* (full)		
A7	Orange	Red***	12	A7	Blue	Red* (full)	24	
A8		Black** *		A8		Black* (full)		
Connector X3				Label printing				
Connector X3	Color	Identification	Subscriber No.	Label	Main label	Label 1	Label 2	Label 3
C1	Grey	Red* (full)	25	Label printing	xxxxxx xx L=XXX	UP X1	UP X2	UP X3
C2		Black* (full)						
B1	Pink	Red I	26	Label type	HB11	HB03	HB03	HB03
B2		Black I						
A1	Orange	Red I	27	Paste mode	Roll	Flat	Flat	Flat
A2		Black I						
C3	Green	Red I	28					
C4		Black I						
B3	Blue	Red I	29					
B4		Black I						
A3	Grey	Red I	30					
A4		Black I						
C5	Pink	Red II	31					
C6		Black II						
B5	Blue	Red II	32					
B6		Black II						

Figure 4-47 Pinouts of the LC telephone line

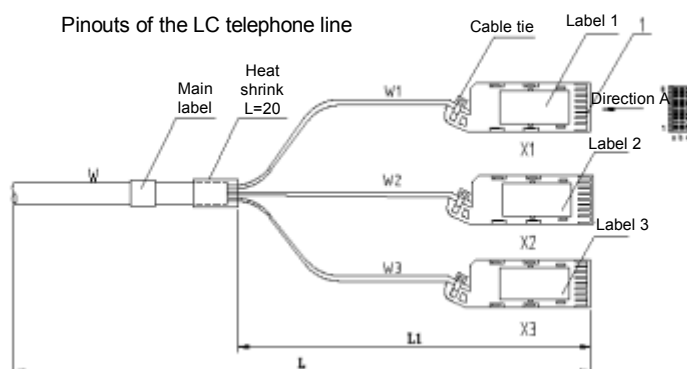

Table 4-4 Pinouts of the LC telephone line

Connector X1				Connector X2				
Connector X1	Color	Identification	Subscriber No.	Connector X2	Color	Identification	Subscriber No.	
C1	Pink	Red*	1	C1	Green	Red***	13	
C2		Black***		C2		Black***		
B1	Orange	Red*	2	B1	Blue	Red***	14	
B2		Black***		B2		Black***		
A1	Green	Red*	3	A1	Grey	Red***	15	
A2		Black***		A2		Black***		
C3	Blue	Red*	4	C3	Pink	Red****	16	
C4		Black***		C4		Black		
B3	Grey	Red*	5	B3	Orange	Red****	17	
B4		Black***		B4		Black		
A3	Pink	Red***	6	A3	Green	Red****	18	
A4		Black**		A4		Black		
C5	Orange	Red***	7	C5	Blue	Red****	19	
C6		Black**		C6		Black		
B5	Green	Red***	8	B5	Grey	Red****	20	
B6		Black**		B6		Black		
A5	Blue	Red***	9	A5	Pink	Red* (full)	21	
A6		Black**		A6		Black* (full)		
C7	Grey	Red***	10	C7	Orange	Red* (full)	22	
C8		Black**		C8		Black* (full)		
B7	Pink	Red***	11	B7	Green	Red* (full)	23	
B8		Black***		B8		Black* (full)		
A7	Orange	Red***	12	A7	Blue	Red* (full)	24	
A8		Black***		A8		Black* (full)		
Connector X3				Label printing				
Connector X3	Color	Identification	Subscriber No.	Label	Main label	Label 1	Label 2	Label 3
C1	Grey	Red* (full)	25	Label printing	xxxxx xxx L=XX X	DOW N X1	DOW N X2	DOW N X3
C2		Black* (full)						
B1	Pink	Red I	26	Label type	HB11	HB03	HB03	HB03
B2		Black I						
A1	Orange	Red I	27	Paste mode	Roll	Flat	Flat	Flat
A2		Black I						
C3	Green	Red I	28					
C4		Black I						
B3	Blue	Red I	29					
B4		Black I						
A3	Grey	Red I	30					
A4		Black I						
C5	Pink	Red II	31					
C6		Black II						
B5	Blue	Red II	32					
B6		Black II						



prompt

The pinouts of the VDSL subscriber cable are the previous 24 pins.

Note the following requirements when connecting the subscriber cables:

- The cabling boards in the middle should be fully utilized and the binding should be neat and make preparations for later expansion.
- The cabling should be on the right primarily to ease cable installation and future cable expansion.
- Pay attention to the angle when inserting the cables into sockets. Do not bend the pins.
- The cables should be bound in order and uniformly.
- The sockets not plugged with any cable must be installed with claw locks to avoid loss.
- Try to separate the power cables, working ground cables and protection ground cables from the subscriber cables.

The techniques for binding the subscriber cables are as follows:

- The cables of the racks should be bound orderly, clearly and neatly. Bind the cable ties in a round shape, and route the cables from the cabling holes on the flank of the rack to the rear side of the rack before upward cabling or downward cabling. For a nice appearance, all the cables should be arranged to both sides along the beams of the frames and led out along the sides. The cable ties should be spaced evenly and bound properly. Excessive length of the tie heads should be cut off so that the cable tie heads all have the same length.
- Cables from the cabinet to the distribution frame should be bound and then placed neatly and closely.
- When supports and antistatic floorboards are installed for the equipment, it is recommended to lay the cables in the method of downward wiring for easy and nice layout. If no support is installed for the equipment, the cables should be laid by means of upward wiring. In this case, cabling racks should be provided above the cabinet. When upward wiring is adopted, cables should be laid through the cabling racks or cabling troughs on top of the rack.
- The size, route, cross-sectional area and position of the distributed cables should be in compliance with the requirements specified in the construction drawings. All cables should be laid neatly, without crossover or skin damage.
- The subscriber cables should be laid separately from the power supply cables.
- The bending radius of cables should be no less than 40 mm to protect the wire core from being damaged, as shown in Figure 4-48.
- The insulation layer of the cable should not be damaged. The routing of cables should facilitate maintenance and future expansion.
- Cables routed in the cabling racks should be bound and arranged neatly and closely. The cable ties should be spaced evenly and bound properly. If twines are used for binding, they should be waxed.
- Cables laid in a wiring trough may be bound or not bound. But they should be laid out neatly without crossover and should not run beyond the trough. The cables should be tied when led in and led out of the trough or when converting to another direction.
- The labels made by SAGEM sa are used to number both ends of a cable. They are placed 20 mm away from the plugs.

Figure 4-48 Cable bending and binding

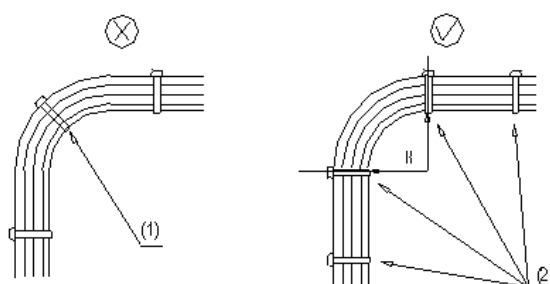



prompt

As shown in Figure 4-48, cable ties cannot be applied in the bending position shown in (1) on the left, and the correct application of the cable ties is shown in (2) on the right.

The cable binding is shown in Figure 4-49 and Figure 4-50:

Figure 4-49 Single binding



Figure 4-50 Double binding

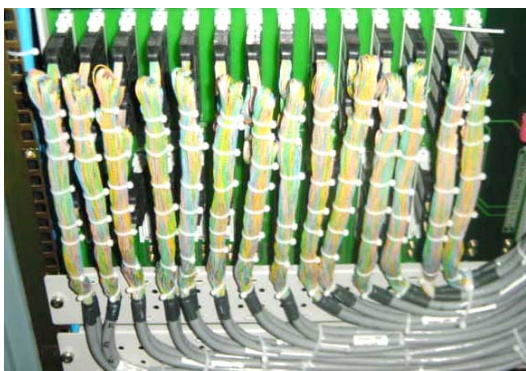

4.8. Connecting the Console Cable

The 3P@C 4450E switch provides RS-232C interface (Console interface) of the RJ-45 type, via which the switch can be connected to the terminal console PC with a console cable. The console cable is an 8-core cable, with an RJ45 connector at one end for connecting to the console interface of the switch and DB9 plug at the other end for connecting to the terminal console. The console cable and the console interface are connected as shown in Figure 4-51. After the connection, you can configure the switch through command lines at the terminal console for outband management.



prompt

For the description of the RJ-45 connector, please refer to Section 4.4.4.

Figure 4-51 Console interface connection

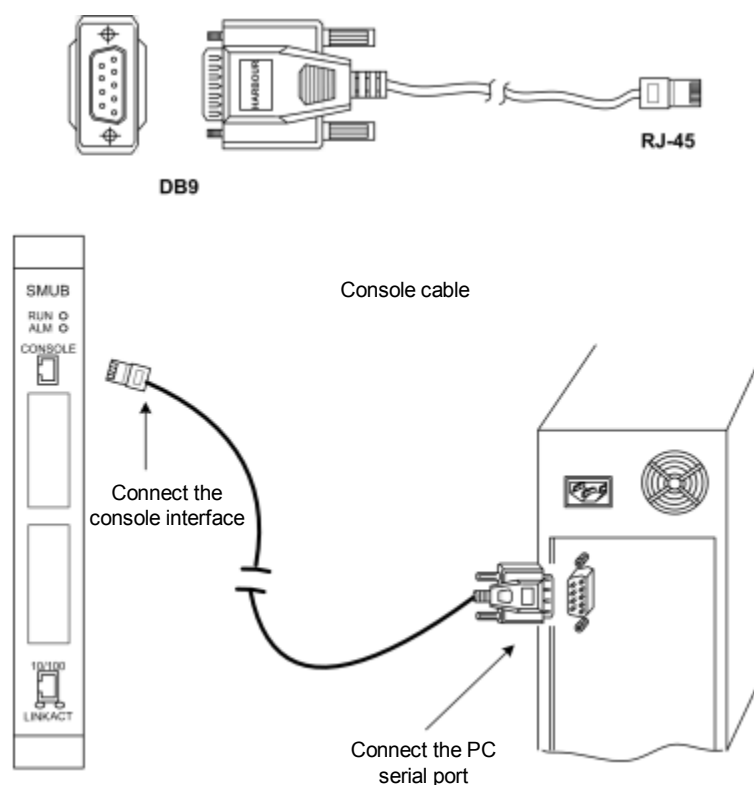

Then start the HyperTerminal on the PC: Start → Programs → Accessories → Communications → HyperTerminal. Install the HyperTerminal through the control panel if it has not been installed. For the HyperTerminal installation method, please refer to the Help information in Windows.

Start the HyperTerminal. If it is started for the first time, you will be required to input a name and select an icon, as shown in Figure 4-52.

Figure 4-52 Input the connection name and select an icon for it



Click <OK> to select the serial port to be connected. Note that the serial port selected must be consistent with the one used by your PC.

Figure 4-53 Select the connecting serial port



Then set the parameters such as the communication rate, as shown in Figure 4-54.

Figure 4-54 Communication parameter setting

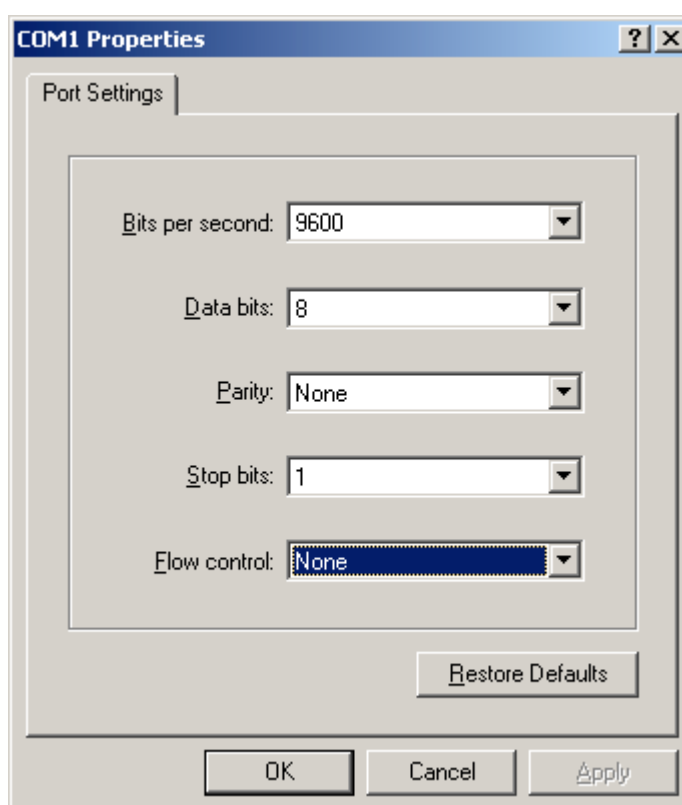

You must set them as follows:

- Baud rate – 9600
- Data bit - 8
- Stop bit - 1
- Parity bit – None
- Flow control – None

Click the Properties item under the File menu of the HyperTerminal, and click Settings in the pop-up window, as shown in Figure 4-55:

Figure 4-55 Select the terminal emulation type

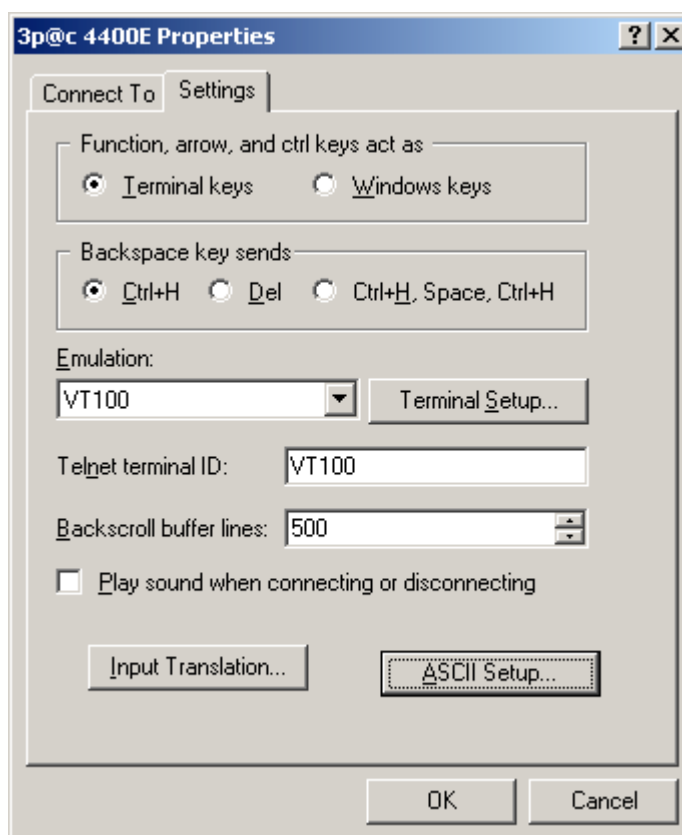

Set the terminal type as VT100.

If the switch has been started (automatically upon power-on), you can conduct the related operations now. Click Dial in the toolbar to log in to the system.

CHAPTER 5

5. Suggestions to Ethernet Cabling

To lessen the possibility of equipment damage and performance deduction due to electromagnetic wave and lightning interference, the following recommendations are offered for 100 Mbps Ethernet port cabling in actual engineering:

5.1. Requirements for Cable Types

Cables for 100 Mbps Ethernet port connection must be Category-5 or Enhanced Category-5 cables. On the surface of the twisted pair, you can often find some symbols like “ 24AWG CAT5”. “CAT5” represents Category-5 twisted pairs and “CAT5E” represents Enhanced Category-5 twisted pairs.

5.2. Requirements for Cabling Length

Length of 100 Mbps Ethernet cabling cannot exceed 100 meters, that is to say, the cable length from a device to a networking device or subscriber's PC must be not more than 100 meters, as shown in the figure below. Cabling length of more than 100 meters influences effective transmission of data.

Figure 5-1 Requirements for cabling length

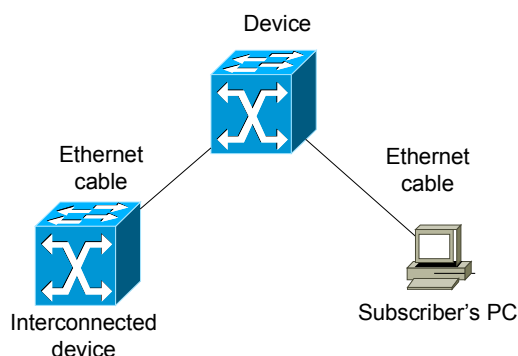

5.3. Spacing Requirements for Indoor Cabling

To keep effective data transmission and lessen interference of coupling high-frequency electromagnetic wave and lightning, it is recommended that in indoor cabling, Ethernet cables should keep an appropriate spacing from other pipelines and nearby electric equipments such as electromotor and transformer that may cause high-frequency electromagnetic interference. For the spacing requirements for indoor cabling, see 0 and 0.

Table 5-1 Requirements of spacing between Ethernet cables and cables of other electric devices

Cable type	Laying mode	Minimum parallel net spacing L(mm)
380 V power cable <2kV.A	Parallel laying	130
	One side is placed in a grounded metal trough or steel tube.	70
	Both sides are placed in a grounded metal trough or steel tube.	10
380 V power cable 2 – 5kV.A	Parallel laying	300
	One side is placed in a grounded metal trough or steel tube.	150
	Both sides are placed in a grounded metal trough or steel tube.	80
380 V power cable >5kV.A	Parallel laying	600
	One side is placed in a grounded metal trough or steel tube.	300
	Both sides are placed in a grounded metal trough or steel tube.	150



Prompt

If the spacing length between a 380 V power cable (<2kV.A) and a Ethernet cable is not more than 10 m with both placed in a grounded trough, the minimum parallel net spacing can be 10 mm.

Table 5-2 Requirements of spacing between the Ethernet cables on the wall and other pipelines

Other pipelines	Minimum parallel net spacing L(mm)	Minimum net spacing between crossed cable and line H(mm)
	Ethernet cable	Ethernet cable
Cable for conducting lightning to the ground	1000	300
protection grounding	50	20
Water supply pipe	150	20
Compressed air pipe	150	20
Thermo pipe (non-enveloped)	500	500
Thermo pipe (enveloped)	300	300
Gas pipe	300	20

The following figure shows the parallel and crossed net spacing between Ethernet cable and other pipelines:

Figure 5-2 Parallel and crossed net spacing

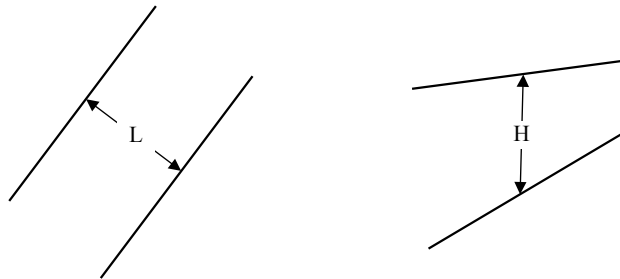

In certain sections, if the Ethernet cable is parallel with the power cable or near interference sources such as electromotor and transformer, and the minimum net spacing between them cannot address requirements, you can use steel tube or metal trough to shield the Ethernet cable.

5.4. Several Forbidden Overhead Cabling Methods

Because outdoor overhead cabling is easy to couple up lightning and damage equipments, it is forbidden to use the outdoor overhead Ethernet cabling, especially use the following cabling methods directly without any protection measures.

Figure 5-3 Direct overhead cabling between two buildings without any protection (1)

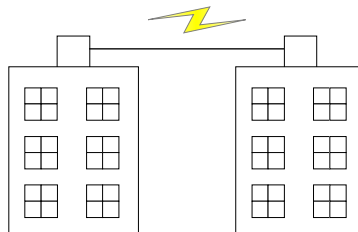

Figure 5-4 Direct overhead cabling between two buildings without any protection (2)

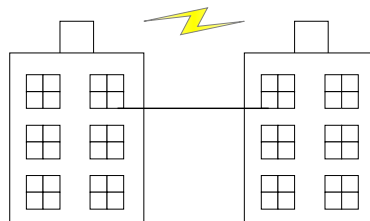

Figure 5-5 Direct overhead cabling between two buildings without any protection (3)

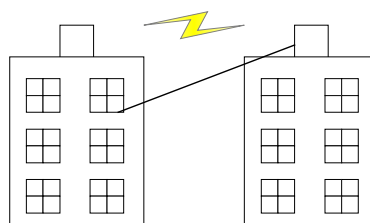
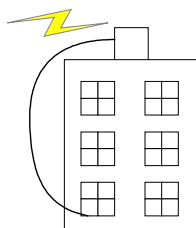

Figure 5-6 Direct overhead cabling from the outdoors of the top of a buildings to the bottom floor without any protection



5.5. Other Requirements for Outdoor Cabling



Note

When connecting devices located in different buildings, you are recommended to use optical cables for overhead cabling, and don't need to install any lightning arrester.

If you cannot provide the optical fiber cable for outdoor cabling and have to use the twisted pair, pay attention to the following cabling requirements:

If the shielding of Ethernet cables is required outdoors, you need to do as follows: Parallelize a steel wire outside the PVC pipe and connect the wire with the lightning protection grounding of the building, in this way the inductive lightning can be conducted to the ground through the steel wire.

The Ethernet cables entering a building must be laid in a weak electricity metal rack or tube. The metal rack or tube serves as the shielding layer of the cable and should be connected appropriately with integrated grounding system. Note that the weak electricity conducting cable cannot share metal rack or tube with the strong electricity conducting cable.



Note

If you cannot provide the optical fiber cable for outdoor cabling and have to use the twisted pair, it is strongly recommended to use the external lightning arrester for lightning protection of the equipment. See the next section for its installation. The external lightning arrester should be provided by users themselves.

5.6. Installing External Lightning Arrester

The external lightning arrester is installed between the signal channel and the protected equipment using a serial connection. The following figure shows its connection.

Figure 5-7 Connection of the external lightning arrester

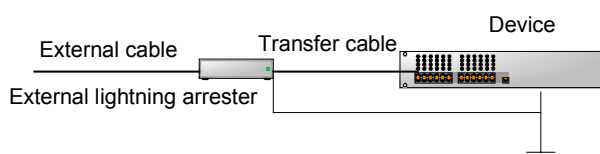

For specific installation procedure and precautions of the external lightning arrester, see the product instructions. The basic installation procedures are as follows:

Step 1	Connecting the Grounding Cable. Connect the grounding cable of the external lightning arrester to the grounding screw stably and check that the length of the tieline is long enough.
Step 2	Use a multimeter to check whether its grounding cable is well connected to the grounding screw and chassis
Step 3	Based on the description of the product instructions, connect the lightning arrester with the equipment network interface through the tieline and with external cables at the same time. Then check whether the network interface LED is operates normally.



Examine the interface identification of the external lightning arrester carefully, do not connect the external cable and tieline to the equipment inversely.

Step 4	Fix the external lightning arrester and bind cables in an orderly fashion.
--------	--

CHAPTER 6

6. System Configuration and Management

6.1. Equipment Power-on

When the 3P@C 4450E is installed, you may power it on. The following phenomena will occur when the equipment is powered on:

- First the RUN indicator of the SMUB will be on, and the RUN indicator of the ADUB/ADUC or the VDUB will start to flash.
- After that, the 3P@C 4450E switch will conduct self-check and begin to load system software. At this time, the "LINK" indicator of a port that has been connected reliably will be solid on while the ACTIVE indicator will be off. About 90 seconds later, the switch enters the normal working state. For the connected port, if the ACTIVE indicator starts flashing, it indicates that this port is transmitting or receiving data.
- If the Console interface is now connected to a PC with a HyperTerminal, then such product information as company name, product serial number and hardware and software versions will be displayed on the PC screen, and operation prompt will be given when the self-check is completed. After you correctly log in the system, you may enter the command line management system to perform 3P@C 4450E configuration and management. For the specific configuration method, please refer to the *3P@C 4450E IP-DSLAM Software Configuration Manual*. If the Console interface is not connected to the PC, please refer to the Console interface connection described in Chapter 4.

6.2. Setting Up the Configuration Environment

6.2.1. Local Configuration via the Console Interface

When the 3P@C 4450E is powered on, the system will first complete the self test. If everything is normal, the 3P@C login interface will appear. The specific procedure is shown as follows:

Step 1	Connect the Console interface on the SMUB to a certain terminal according to the method described in Chapter 4, and conduct the corresponding setting.
Step 2	When the 3P@C 4450E is powered on, such information as company name, production date and product version and some self test information of the system are displayed on the terminal screen first, as shown in the following: 3P@C 4450EV2 Boot Loader Version 2.03 Compiled: May 23 2003 14:46:07 SDRAM test...passed. Base ethernet MAC address: 00:05:3b:00:04:99 Uncompress start...

```
Uncompress success, enter device initialize, Please wait...
Entering 3P@COS .....Done.
Initializing environment ..... Done.
Loading startup config ..... Done.
```

```
#####
####
# #
# Welcome to 3P@COS. #
# #
# Press Return to connect and config this system. #
# #
#####
####
```

3P@COS V2.0Release7.4.0 on 3P@C 4450EV2.0.

Login:

Step 3	When pressing <Enter> on the terminal, the system prompts you to input the login user name and password.
Step 4	The default user name for the login at the first time is "admin" and the password is "3P@C". The user logging in with this user name and password has the administrator rights. The display is shown as follows: Login: admin Password: ***** You will first enter the read-only mode of the system after successfully logging into the system. The command prompt is "3P@C>". In this mode, you can only view the system configuration information, since common users can only enter the read-only mode. If you have the administrator rights and hope to configure the equipment, enter the configuration mode according to Step 4.
Step 5	Enter the configuration mode. Input the enable command in the read-only mode. Then the system requests you to input the password for entering the configuration mode. The default password is "3P@C", as shown in the following: 3P@C>enable Password: ***** After you successfully enter the configuration mode, the command prompt becomes "3P@C(config)#". In this mode, you can perform all the configuration operations on 3P@C 4450E. For the detailed description of the related configuration commands and methods, please refer to the <i>3P@C 4450E IP-DSLAM Configuration Manual</i> .
Step 6	Save the configuration information. To make the equipment configuration still effective after the equipment is restarted, you need to use the save configuration command to save the configuration information. For example, 3P@C(config)# save configuration Press Enter and wait for the system to save the configuration information.
Step 7	Exit the configuration mode. In the Configuration Mode, you may use the exit command to exit the Configuration Mode and go back to the read-only mode. You may also use the exit command in the read-only mode. However, it only functions to exit the 3P@COS, similar to the function of the logout and quit commands. To exit the 3P@COS, use the logout or quit command, or use the exit command in the read-only mode.

6.2.2. Remote Configuration via Telnet

3P@C 4450E supports the Telnet remote management. The 10/100M interface on the SMUB of 3P@C 4450E can be connected to the LAN, and you may log in to 3P@C 4450E by Telnet remotely through the computer in the LAN, thus implementing remote configuration management. The connection diagram is shown in Figure 6-1.

Figure 6-1 Remote management of 3P@C 4450E via Telnet

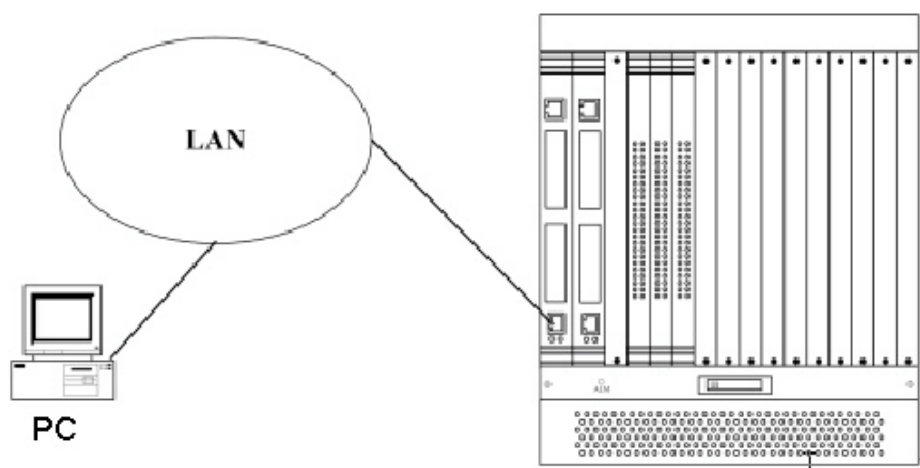

To implement remote management of Telnet, take the following steps:

Step 1	Enter the command line management system 3P@COS via the Console interface, and enter the Configuration Mode according to the method mentioned above.
Step 2	Set IP address for 3P@C 4450E. The 3P@C 4450E switch has a default VLAN named "default". Set an IP address for the VLAN. This IP address will serve as the ID of the 3P@C 4450E in the network. <code>3P@C(config)# config vlan default ipaddress 10.10.10.1/24</code>
Step 3	Log in to the 3P@C 4450E by Telnet from the computer. <code>telnet 10.10.10.1</code> Then input the user name ("admin" by default) and password ("3P@C" by default) and you can log in successfully.

6.3. Command Line System

3P@C 4450E adopts the 3P@COS. 3P@COS is the operating system developed specially for its 3P@C series of products.



Note

All the commands of the 3P@COS command line are case insensitive.

6.3.1. Command Mode

There are two command modes for the 3P@C 4450E IP-DSLAM : Read-only mode for ordinary users and configuration mode for administrators. For descriptions of the two command modes, refer to Table 6-1.

Table 6-1 Description of the read-only mode and the configuration mode

Command mode	Function	Applicable users	Command prompt
Read-only mode	View most of the system information and configuration information of the switch	Ordinary user	3P@C>
Configuration mode	View and configure all the information of the switch	Administrator	3P@C(config)#

The user that logs in the system with default user name “admin” and password “3P@C” is called an administrator who can configure and operate the switch in both read-only and configuration modes. After the administrator inputs the correct login username and password, he will first enter the read-only mode. To enter the configuration mode, he needs to use the **enable** command and input the password for entering the configuration mode. The administrator has both the rights to configure the switch and the rights to manage the users, including creating/deleting users, modifying user rights, modifying login password and the password for entering configuration mode.

6.3.2. Common Commands

For a preliminary understanding of the usage of the 3P@C 4450E commands, the following introduces the usage method of some common commands, as shown in Table 6-2 and Table 6-3.

Table 6-2 Commands in the read-only mode

Command	Function
clear	Clears the screen display
enable	Enters the configuration mode to perform configuration and write operations on the switch
exit	Exits the current configuration mode and returns to the previous mode. If executed in the read-only mode, this command will enable users to exit from the system.
help	Shows how to use the syntax help in the command line
list	Shows the list of current available commands
logout	Logs out and disconnects

Command	Function
quit	Quits the command line and disconnects (this command has the same function as logout)
show history	Shows the history commands that have been input
show services	Shows the services provided by the current system
show version [all <0-15>]	Shows the version information of cards
terminal length <value>	Sets the number of lines output per screen of the terminal
who	Shows the users connected to the switch currently
who am i	Shows the information of the current user
show idle-timeout	Shows the idle timeout time
show time	Shows the current time of the system

All commands except **enable** in the read-only mode are also effective in the configuration mode, so they are omitted in Table 6-3.

Table 6-3 Common commands in the configuration mode

Command	Function
enable-password	Modifies your own password to enter the configuration mode
config time <1970-2069> <1-12> <1-31> <HH:MM:SS>	Configures the system time
erase {startup-config}*1	Erases the system start-up configuration saved in the switch
hostname <hostname>	Renames the switch, for example, the default name of this switch is 3P@C
idle-timeout <value>	Sets the idle waiting time of 3P@C 4450E before the system automatically enters the state before login
show running-config	Shows the running configuration of the system
show startup-config	Shows the startup configuration of the system
save {configuration}*1	Writes and saves the running configuration in the switch

6.3.3. Online Help of Command Line

3P@C 4450E provides abundant online help information to help users input the commands.

- You can enter **<help>** in any command mode to get a brief description of the help system.
- There is built-in syntax help in the command line interface. If you are not sure of the syntax of a certain command, you may input the known former part of the command and key in “?”. Then the command line prompts you the meaning or function of the command. If you input a space and “?” after the command, the command line will prompt the possible commands after the part of command you input. Then you may continue to input the command as prompted till the following appears:

<cr> Just Press Enter to Execute command!

It shows that the complete command has been input. Press Enter to execute it.

6.3.4. Command Line Edit Feature

Table 6-4 lists the line editing commands that can be used in the command line.

Table 6-4 Line edit commands in the command line

Command	Function
Back Space or Del or Ctrl+h	Deletes a character to the left
Up arrow key, or Ctrl+p	Invokes the previous history command
Left arrow key or Ctrl+b	Moves the cursor to the left by a character
Right arrow key or Ctrl+f	Moves the cursor to the right by a character
Down arrow key or Ctrl+n	Shows the next history command if the up arrow key has been used previously to invoke the previous history command
Ctrl+a	Moves the cursor to the beginning of the line
Ctrl+e	Moves the cursor to the end of the line
Ctrl+d	Deletes the character where the cursor is
Ctrl+k	Deletes all characters after the cursor
Ctrl+t	Changes the character where the cursor is with that on the left of the cursor, and moves the cursor to the right by a character
Ctrl+u	Deletes the whole line
Ctrl+w	Deletes all characters on the left of the cursor



prompt

Of the above commands, Del, up arrow key, down arrow key, left arrow key and right arrow key only support the mode of using Telnet to configure the switch, rather than serial interface configuration. However, the Ctrl+h, Ctrl+p, Ctrl+b, Ctrl+f and Ctrl+n commands all support the above two login modes.



prompt

For details of the commands, see the 3P@C 4450E IP-DSLAM Software Configuration Manual.

6.4. System Management

6.4.1. Storage Media and File Type

The 3P@COS, configuration file and other applications of 3P@C 4450E are saved in the Flash. See Table 6-5 for the related file types.

Table 6-5 Correspondence between file types and command line parameters of 3P@C 4450E

Parameter	Description
3P@COS	3P@COS operating system
config-file	Configuration file
adufpga vdubfpga	FPGA code of ADU and VDU

Parameter	Description
Bootrom	Code of Bootrom part 2. The Bootrom of 3P@C 4450E comprises two parts. The second part can be downloaded. If you do not download this part, the system startup will not be affected. Therefore, it is suggested not to download this part if you are not clear about this structure of 3P@C 4450E Bootrom, lest disastrous results be caused.
Gtiooct	Globespan ADSL chipset code

6.4.2. Program File Management

The software upgrade or download of 3P@C COS can be conducted in the Xmodem or FTP mode and saved in the Flash.



prompt

For details, see the 3P@C 4450E IP-DSLAM Software Configuration Manual.

6.4.3. Configuration File Management

To make it convenient for you to configure the xDSL port of 3P@C 4450E, we have created the port configuration files, which enable you to directly configure the ports of different types, for the purpose of easy-to-use, high efficiency and time-saving.



prompt

For details, see the 3P@C 4450E IP-DSLAM Software Configuration Manual.

PART II

Maintenance

CHAPTER 7

7. System Maintenance

7.1. System Upgrade

7.1.1. Storage Media and File Type

The storage media include:

- DRAM (Dynamic Random Access Memory): The program of the system control board runs in the DRAM.
- Flash (Flash Memory): It saves the software of the system control board and configuration files.

The system supports four types of files:

- System file: Includes the program files of all modules and the FPGA code of the ADU and VDU. The system file is a compressed file, and cannot implement system boot. For example, 04110468_DS41SMU_xducode_V02R00B10D04_20040915.bin.
- Program file of system control board: Used for the system control board to boot the system. It is usually hos_smu_vxxrxbxxdxx.bin, for example, hos_smu_v02r00b09d06.bin.
- Configuration file: It is a text file that records user configuration information.
- LOG file: System log file.



prompt

For the V1.00 hardware, the VDU needs to upgrade (board operating system). The download method is the same as other methods.

7.1.2. Sequence of System Upgrade

System upgrade includes system file upgrade and upgrade of the program of system control boards without special sequence requirements. However, the version of the system file must be consistent with that of the program of the system control board. Otherwise, it may cause some abnormal symptoms.

7.1.3. Upgrading the System File

You can upgrade the system file in two modes:

- Upgrade the system file through the BOOTROM during equipment power-on

This mode is used under such circumstances: The equipment cannot be started normally because of a failure, so you cannot upgrade the system file through a command line; or software is loaded for the first time before the equipment is delivered (upgrade in the FTP/Xmodem mode).

- Upgrade the system file through a command line in compliance with the FTP/Xmodem protocol after the equipment is started

1. 1. 1. 51 Upgrade through BOOTROM

During code start, you can download the system software to the hard disc or mobile storage equipment.

During the power-on, the BOOTROM menu prompts you to upgrade the system software in two ways: Upgrade through network ports, and upgrade through the Console port. Normally, you are suggested to upgrade the system file through the network port. It is because the system software is large, while the download speed through the Console port is very low.

1. 1. 1. 51. 1 Upgrade the system software through the network port**Step 1: Set the FTP server remotely**

In this mode, you need to establish an FTP server in the terminal storing the program file, connect the equipment to be upgraded with the FTP server through the specified port, and establish a user name and password in the FTP server.

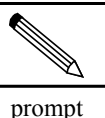

SAGEM sa does not provide the FTP software, so users need to prepare or purchase such software. The 3Cdaemon software of 3COM is recommended.

Step 2: Enter the main menu of the Bootrom

During equipment start, press and hold <Space> to enter the main menu of the Bootrom as follows:

3P@C 4450E Boot Loader V2.21

Compiled: Jan 3 2004 13:21:04

SDRAM test....passed.

Base ethernet MAC address: 00:05:3b:48:47:fd

- ? - List all available commands
- h - List all available commands
- g - Boot an executable image
- dl - Enter download mode to load new image or config file
- r - Reboot system

Press 'h' or '?' To get helping information.

3P@C:

Table 7-1 Bootrom command

Serial No.	Item	Description
1	?	List all available commands
2	h	List all available commands
3	g	Exit from the menu, and continue the system load process. That is, implement the system boot file in the current system.
4	dl	Enter the download mode to download the configuration file of system file
5	r	Reboot the system

Step 3: Enter the upgrade submenu

After entering the Bootrom main menu, select the fourth option: dl to enter the sub-menu as follows:

you enter download mode

- ? - List all available commands
- h - List all available commands
- n - Exchange load mode(default FTP)
- p - Print boot parameters
- c - Change boot parameters
- a - Download system image to Flash
- A - Download system image and boot
- s - Download system base config information
- fa - Download ADU fpga code
- fv - Download VDU fpga code
- da - Download ADU chip code
- dv - Download VDU chip code
- load <filename> - Download file to Flash
- del <filename> - Delete a file in Flash
- rename <oldname> <newname> - Rename a file in Flash
- erase fileinfo - Erase files in Flash, all files will be lost!
- show flash - Show Flash file info
- x - Quit

Table 7-2 Upgrade submenu in the network port

Serial No.	Item	Description
1	?	List all available commands
2	h	List all available commands
3	n	Change the download mode, use Xmode or FTP (default) mode
4	P	Print the current download configuration parameters

Serial No.	Item	Description
5	c	Change the current download configuration parameter (user name and password)
6	a	Download the system image file (program file of system control board) to 3P@C 4450E
7	A	Download the system image file (program file of system control board) to 3P@C 4450E, and reboot the system
8	s	Download the configuration file
9	fa	Download the ADU FPGA code
10	fv	Download the VDU FPGA code
11	da	Download the ADU chipset code
12	fa	Download the VDU chipset code
13	remove <filename>	Download the file to Flash
14	remove <filename>	Delete the files in Flash
15	rename <old_filename> <new_filename>	Rename the files in Flash
16	erase fileinfo	Delete all files in Flash
17	show flash	Show the information of all files in Flash
18	x	Exit from the current download mode

Step 4: Change relevant parameters of the network port

Select **c**, and press Enter to begin interactive setting.

Table 7-3 Relevant parameters downloaded by the network port of system control board

Item	Default value	Description
boot device		boot device name, which generally need not be modified
processor number	0	Need not be set
host name :		Need not be set
file name		The name of the version file to be upgraded. It needs to be modified as the actual system file name. hos_smu_v02r00b09d06.bin
inet on ethernet(e)		The IP address assigned to the network port of the system control board. It must share the same network segment with the IP address of the host of the FTP server.
inet on backplane(b) :		Need not be set
host inet(h)		The IP address of the host of the FTP server. It must share the same network segment with the IP address assigned to

Item	Default value	Description
		the network port of the system control board.
gateway inet(g)	:	Need not be set
user(u)		The user name assigned to the FTP server
ftp password (pw)		The assigned password corresponding to the user name
flags(f)	: 0x0	Need not be set
target name(tn)	:	Need not be set
startup script(s)	:	Need not be set
other(o)	:	Need not be set



The black items must be set manually.

prompt

Step 5: Select the media of downloading the upgrade file

After modifying all parameters, select different command according to the type of the downloaded file. For example, “a” indicates the program file of the system control board, and “da” indicates the ADU chipset code. For details, see the description of download menu above.

Step 6: Return to the main menu

After completing the download, select the 18th option: x, to return to the main menu.

Step 7: Reboot

Select r in the main menu to reboot the system.

1.1.1.51.2 Upgrade the system software through the Console port

In this mode, the terminal needs to support the Xmode of sending files. Preferably, the baud rate can reach 115,200 to improve the download speed.

Step 1: Connect the cables

Connect the Console port of the system control board with the serial ports of the terminal through the cables attached, as shown in the figure below.

Figure 7-1 Connecting the console cables

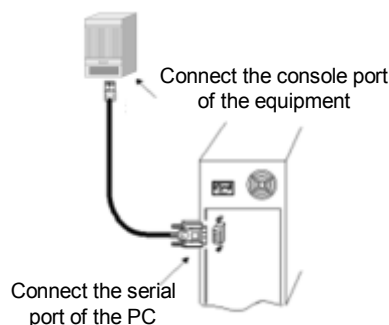



You must configure the terminal correctly.

prompt

Step 2: Start the equipment and enter the main menu of the Bootrom

Power on the equipment, and press <Space> repeatedly. If the "3P@C" prompt appears, it indicates that you have accessed the Bootrom menu. The information of the menu is shown as follows:

3P@C 4450E Boot Loader V2.21

Compiled: Jan 3 2004 13:21:04

SDRAM test....passed.

Base ethernet MAC address: 00:05:3b:48:47:fd

- ? - List all available commands
- h - List all available commands
- g - Boot an executable image
- dl - Enter download mode to load new image or config file
- r - Reboot system

Press 'h' or '?' To get helping information.

3P@C:

For menu options and their meanings, see Figure 7-1.



You can upgrade the 3P@COS software in the Xmodem mode. Alternatively, you can download new host program in the FTP mode and save the program to Flash.

prompt

Step 3: Enter the download submenu

Select the No. **dl** option to enter the download mode as follows:

you enter download mode

- ? - List all available commands
- h - List all available commands
- n - Exchange load mode(default FTP)
- p - Print boot parameters
- c - Change boot parameters

a - Download system image to Flash
A - Download system image and boot
s - Download system base config information
fa - Download ADU fpga code
fv - Download VDU fpga code
da - Download ADU chip code
dv - Download VDU chip code
load <filename> - Download file to Flash
del <filename> - Delete a file in Flash
rename <oldname> <newname> - Rename a file in Flash
erase fileinfo - Erase files in Flash, all files will be lost!
show flash - Show Flash file info
x - Quit

For the description of menu options, see Figure 7-2.

Step 4: Modify the download mode as Xmodem

Enter a command n, you can select either Xmodem or FTP mode. Here, select Xmodem.

Step 5: Enable the corresponding function option to download the software

Enter a command a, and the system prompts:

Downloading, please wait...

Please set console baud rate 115200

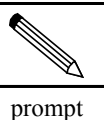

When you use the 3P@C 4450EV2.00 hardware, the system will prompt you to modify the baud rate as 115,200. In the case of the 3P@C 4450EV2.00 hardware, the baud rate needs to be set to 9,600 when you connect 3P@C 4450E through the serial port. Then, you need to disconnect 3P@C 4450E first, modify the baud rate, and connect 3P@C 4450E again.

The system is waiting for the terminal to send files through the Xmodem protocol. Click [Send/Send files] to initiate the function of sending files, and select the [Xmodem] protocol. Click <Browse> to choose the path of the main file, and click <Confirm>. The terminal begins to send files, as shown in the figure below:

Figure 7-2 choosing the file to be sent

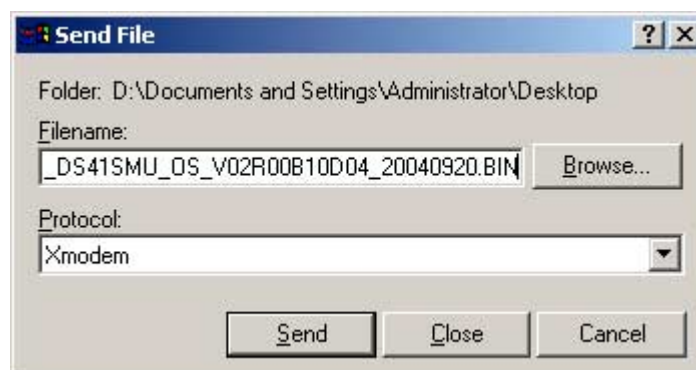
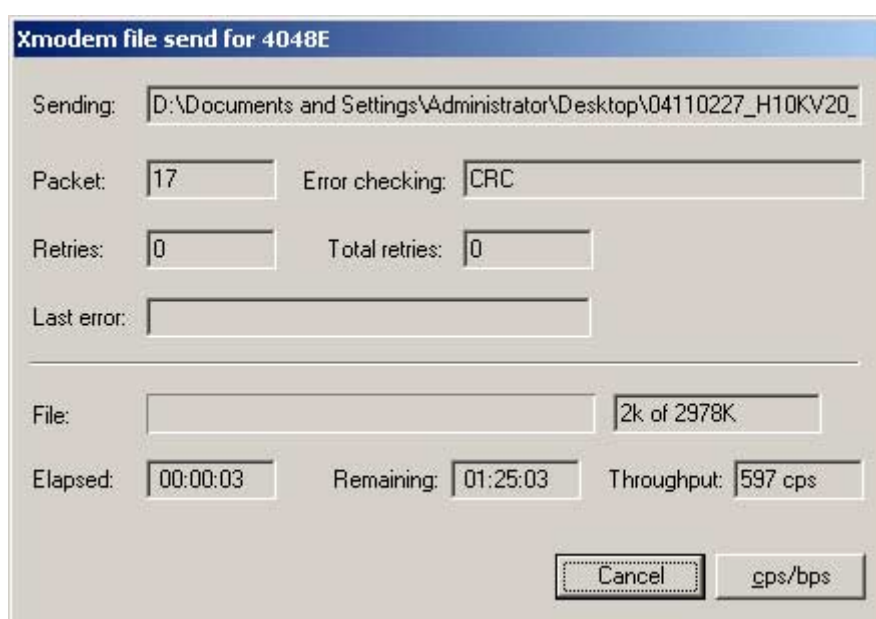

Figure 7-3 File transfer interface



Step 6: Return to the main menu

After the file is transferred successfully, the above interface disappears. The system returns to the serial port menu (set the rate to 9,600 bps). Execute the command **x** to return to the Bootrom main menu.

1. 1. 1. 52 Upload/download the system file through FTP

3P@C 4450E can upload and download the system software through FTP.

The upload/download operation is implemented for the client. The download operation is to obtain the file of the server side. The upload operation is to transfer the file of the client to the server side.

3P@C 4450E can sever as the server side or the client of the FTP.

- If 3P@C 4450E serves as the server, you can transfer the system file to the equipment through the command **upload ftp [config-file] <A.B.C.D> <username> <password> <filename>** in the client PC (containing the system file).
- If 3P@C 4450E serves as the client, you can download the system file in the remote server PC to the local equipment through the command **download ftp [3P@COS|config-file|xducode|vduos] <A.B.C.D> <username> <password> <filename>** in the 3P@C 4450E equipment.

In the following procedures, 3P@C 4450E serves as the FTP client, and the remote PC (containing the system file) serves as the FTP server.

Suppose that the IP address of the PC server is 10.1.1.2/24 and that the FTP Server service is enabled. Implement the following procedures in 3P@C 4450E.

Step 1: Connect the equipment to the PC through a network

Figure 7-4 Connection mode

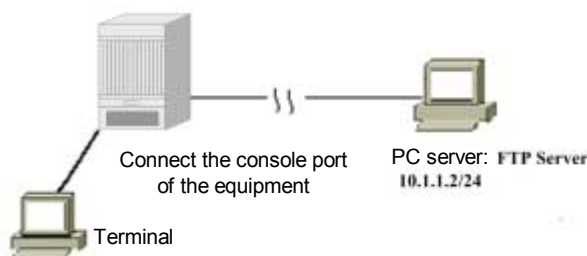

Step 2: Configure the IP address of the equipment interface, and ensure that you can PING through the server

Step 1	Step 1: The user with the administrator right logs in and enters the configuration mode through the serial port or telnet. 3P@C> en Password: 3P@C(config)#
Step 2	Configure 3P@C 4450E and the host where the downloaded file is located well so that they can communicate with each other normally. Enable the FTP Server in the host, and configure the login user name, password and path of downloading the file. 3P@C(config)#
Step 3	Check whether the interworking with the FTP Server. 3P@C(config)#Ping 10.1.1.2

Step 3: Log in to 3P@C 4450E, and download the required file

Step 1	Log in to 3P@C 4450E, input the user name and password to download the required file. 3P@C(config)# download ftp [3P@COS config-file xdrcode vduos] <A.B.C.D> <username> <password> <filename>
--------	---

Step 4: Reboot 3P@C 4450E

Step 1	After the download, input the reboot command to reboot the switch. 3P@C(config)# reboot The following information indicates the download through FTP is successful: Trying download file from ftp server, please wait... Successfully finished receiving file. Trying write file to flash..... Finished. You've successfully download new image file Now you can type reboot command to reboot system.
--------	---

7.1.4. Upgrading the Master System Control Board

You can upgrade the program file of the system control board in the ways below:

- Upgrade the system file through the BOOTROM during equipment power-on

This upgrade way is used under this circumstance: The equipment cannot be started normally, so you cannot upgrade the program file through the command line (separate software of the system control board is required, the name is usually rpu.bin).

- Upgrade the program file through the command line in compliance with the FTP/Xmodem protocol after the equipment is started.

1. 1. 1. 53 Upgrade the program file through BOOTROM

Note that the upgrade is to download the files to be upgraded in a certain way into a storing medium of the equipment and start the equipment through the file.

During the power-on, the BOOTROM menu prompts you to upgrade the master system control board in two ways: Upgrade through network ports, and upgrade through the Console port. Normally, you are suggested to upgrade the system file through the network port. It is because the system software is large, while the download speed through the Console port is very low.

1. 1. 1. 53. 1 Upgrade the master system control board software through the network port

Step 1: Set the FTP server remotely

Step 2: Start the equipment and enter the main menu of the Bootrom

Step 3: Enter the upgrade submenu of the network port

Step 4: Modify download-related parameters of the network port



For operation details, see section 7.1.3.

prompt

Step 5: Select the download file

After modifying all parameters, select the type of the download file. Here, select a or A to upgrade the system control board.

Step 6: Return to the main menu

After the download, select **x** to return to the main menu.

Step 7: Select **r** in the main menu to reboot the system

1. 1. 1. 53. 2 Upgrade the master system control board software through the serial port

In this mode, the terminal needs to support the Xmode of sending files. Preferably, the baud rate can reach 115,200 to improve the download speed.

Step 3: Connection the cable.

Step 2: Start the equipment and enter the Bootrom main menu

Step 4: Select the Xmodem download mode

Step 5: Enable the corresponding function option to download the software



For operation details, see section 7.1.3.

prompt

Step 6: Return to the main menu

After the file is transferred successfully, the above interface disappears. The system returns to the serial port menu. Execute the command **x** to return to the Bootrom main menu.

Step 6: Reboot the system

Execute the command **r** in the main menu to reboot the system.

1.1.1.54 Upgrade through FTP/Xmodem

After starting the equipment, you can upgrade the system control board through FTP or Xmodem. If the user has separate system control board software, you can upgrade the master system control board separately. The operation is similar to that of upgrading the system file as described in section 7.1.3, except that their file names are different from each other. If the user upgrades the software of the master system control board through the system file, follow the procedures below:

Step 1	Download the system software For the downloading method, see section 7.1.3 "Upgrading the System File".
Step 2	When you upgrade the version of the system control board, the system file is <code>hos_smu_v02r00b09d06.bin</code> , the address of the FTP server is <code>20.1.1.11</code> , the user name is <code>hostfile</code> , and the password is <code>drv</code> . <code>3P@C(config)# download ftp 3P@COS 20.1.1.11 hostfile drv hos_smu_v02r00b09d06.bin</code> Trying to download file from ftp server, please wait... 3048756 bytes received. Start saving 3P@COS image... Done. <code>3P@C(config)# reboot</code> Start check image and config file, please wait... ----- Current version is V2.0 Release10.4.0. System version will be V2.0 Release10.4.0 after reboot. Config file latest saved on TUE JAN 02 06:31:25 CST 2001 . ----- Are you sure to reboot the whole system? [Y/N]
Step 3	After starting the equipment, check whether the upgrade is successful or not. ##### # # Welcome to 3P@COS. # # # Press Return to connect and config this system. # # #####

```
login: admin
Password:

3P@C> enable
Password:

3P@C(config)# show version 0
----- Board In Slot 0 Version Information -----

Vlan Type    : SMUB
Hardware     Version : Version 2.30
Software     Version : V2.0 Release10.4.0
(Compiled    Time) : Sep 20 2004 17:06:09
CPLD U14     Version : Verison 9.0
CPLD UD3     Version : Verison 2.0
Manufacture  Date : 2004-02-21
Serial       Number : 02030059D230042000047
Base Mac     Address : 00053b4847fd
```

7.1.5. Upgrading the Standby System Control Board

The standby system control board is upgraded automatically. After the program of the system control board is upgraded in the FTP/Xmodem mode, the system will automatically upgrade the software of the standby system control board if detecting the standby system control board.

In the BOOTROM mode, you need to upgrade the system control board in the FTP/Xmodem mode again after the system control board is upgraded and the system is rebooted. Then the system automatically upgrades the standby system control board.

7.2. Managing the Configuration File

7.2.1. Type and Format of Configuration File

The configuration file is in the text format. It records the configuration information of the equipment, and is used to guide the start or running of the equipment. The configuration file falls into two types:

- **startup-config:** After powered on, the equipment reads the configuration file from the Flash memory to initialize the equipment. Therefore the configuration file in the Flash memory is called startup-config. If there is no configuration file in the Flash memory, the equipment will use the default parameters to initialize itself.
- **show running-config:** During equipment running, the configuration will be effectively instantly. After being saved, the show running-config will become startup-config upon next equipment reboot.

Format of configuration file

- Saved in the command form
- Only non-default constants are saved so as to save space.
- The configuration file is based on the command mode. The commands with the same command mode are listed together. Different command modes are separated by blank lines or remark lines (the lines starting with a “!”).
- End with “end of config”

To view the content of the configuration file, execute the following commands in the configuration mode:

Configuration procedure:

Step 1	show startup-config	View the initial configuration of the equipment
Step 2	show running-config	View the current configuration of the equipment

The following is a configuration file:

Configuration example:

```
3P@C (config)# show running-config
```

```
!3P@COS system config file
idle-timeout 0
!preconfig config
```

```
!Syslog config
```

```
config syslog lowest-level 7
config syslog type NAS enable
config syslog type RADIUS enable
config syslog type DHCPDS enable
config syslog type HIPMG enable
config syslog type PPPOE enable
config syslog type PPP enable
config syslog type L3SWITCH enable
config syslog type SNTP enable
```

Note that the command starting with “!” is remark information.

7.2.2. Backuping the Configuration File

After the user configures the equipment, the user is suggested to backup the configuration file. Then, the user can download the configuration file to the equipment, or load the configuration file to the equipment with similar configuration in case of need.

The example below instructs you how to transfer the system file. The IP address of the FTP server is 20.1.1.1, and the configuration file is renamed as config.txt after the configuration file is transferred to the FTP server.

3P@C 4450E operation procedures:

Step 1	First enable the FTP server and set the user name and password. For example, the user name is “ftpuser” and the password is “123”.
Step 2	Transfer the system configuration file, and execute the commands below in the 3P@C 4450E equipment:

```
3P@C(config)# upload ftp config-file 20.1.1.11 ftpuser 123 config.txt
Trying to upload file to ftp server, please wait...
```

```
Successfully finished uploading file.
```

```
Finished.
```

```
You've successfully uploaded config-file config.txt
3P@C(config)#
```

7.2.3. Loading the Configuration File

If the user's several devices with the same configuration need to be configured, you can edit the configuration file of any of the devices offline in the prescribed format, and transfer the configuration file to the device through the FTP server. To validate the new configuration file, you must reboot the device.

Configuration procedure:

Step 1	First enable the FTP server and set the user name and password. For example, the user name is "ftpuser", the password is "123", and the configuration file is named "config.txt".
Step 2	Download the configuration file in 3P@C 4450E. 3P@C(config)#download ftp config-file 20.1.1.11 ftpuser 123 config.txt
Step 3	Reset the system 3P@C(config)# reboot

7.2.4. Erasing the Configuration File

You can clear the configuration file by executing the command **erase**. After the configuration file is erased, the equipment will use default configuration parameters for initialization upon next power-on. You need to erase the configuration file under one of the circumstances below:

System upgrade

- The configuration file is damaged.
- A mistaken configuration file is loaded.

Configuration procedure:

Step 1	erase	Erase the configuration file from the storage media
--------	-------	---

7.3. Querying the Maintenance Information

7.3.1. Querying the Current Software Version

Operation Guide

Execute the command **show version [all|<0-15>]** to show the version information of all/some cards in 3P@C 4450E.

Reference index

The version information of the system software must be correct. The software versions (3P@COS(tm) Version) of all cards must be consistent with one another. The HardwareVersion and SerialNo. must be consistent with those of the cards.

For example:

```
3P@C(config)# show version 6
```

```
----- Board In Slot 6 Version Information -----
```

```
Board      Type : ADU_GS_32
```

```
Hardware   Version : V0.2:
```

```
FPGA       Version : A1.3
```

```
CPLD       Version : 1.0
```

```
ADU Serial Number : API-71
```

```
ADU Firmware Version : X3727
```

```
ADU Vendor ID : GSPN
```

7.3.2. Viewing the Current Configuration

Operation Guide

Execute the command **show running-config** to show the running configuration of the equipment.

Reference index

The result contains the configuration commands and parameters of all modules.

7.3.3. Querying the Port Status

Operation Guide

Execute the command **show port [<portlist>|all|active]** to query the status information of all ports or specified ports, including the up/down state, port rate, duplex, flow control and self-negotiation mode.

Reference index

The Up/Down state is consistent with the indication in the panel indicator. The rate, duplex, flow control and self-negotiation mode of the port are all correct.

For example: View the status of Port 7:7.

```
3P@C(config)# show port 7:7
```

```
-----  
Port:<7:7> 's Current Value Information
```

```
Link state      : Up      Port state      : enabled
```

```
Port Default VLAN ID : 2374   Port VLAN name   : dsl2374
```

```
Remote modem connection : YES
```

```
Service Mode      : G.dmt   Channel Mode     : Interleaved
```

3P@C Installation Manual

DS Rate(Kbps)	: 7584	US Rate(Kbps)	: 1024
DS NoiseMargin(dB)	: 12.00	US NoiseMargin(dB)	: 8.00
DS Interleaved Delay(ms)	: 16	US Interleaved Delay(ms)	: 8
DS Attenuation(dB)	: 1.50	US Attenuation(dB)	: 0.00
DS Out Power(dB)	: 7.70	US Out power(dB)	: 12.40
DS Attainable Rate(Kbps)	: 10544	US Attainable Rate(Kbps)	: 1157

The parameters are described as follows:

- Link state: Whether the port is in linked (up or down).
- Port state: Whether the port is enabled or not. If the port is in the Disable state, the Link state must be down.
- Port Default VLAN ID: By default, each port belongs to the VLAN created by a system to isolate the ports. This item indicates the ID of the VLAN where the port is located.
- Port VLAN name: Name of the VLAN where the port is located
- Remote modem connection: Whether the port is connected with a PC through a modem
- Service Mode: Port working mode
- Channel Mode: Channel mode
- DS Rate(Kbps): Downstream rate (Kbps)
- US Rate(Kbps): Upstream rate (Kbps)
- DS NoiseMargin(dB):
- US NoiseMargin(dB): Upstream noise margin
- DS Interleaved Delay(ms): Downstream interleaved delay (ms)
- US Interleaved Delay(ms): Upstream interleaved delay (ms)
- DS Attenuation(dB): Downstream attenuation (dB)
- US Attenuation(dB): Upstream attenuation (dB)
- DS Out Power(dB): Downstream output power (dB)
- US Out power(dB): Upstream output power (dB)
- DS Attainable Rate(Kbps): Downstream attainable rate (Kbps)
- US Attainable Rate(Kbps): Upstream attainable rate (Kbps)

7.3.4. Querying the VLAN Status

Operation Guide

Execute the command `show vlan {<name>}*1` to the status of a specified VLAN or all VLANs, including Up/Down state, and the relationship of the port members in the VLAN (Tagged/Untagged).

Reference index

The Up/Down state of the VLAN is normal, and the relationship of the port members in the VLAN (Tagged/Untagged) is consistent with that in the configuration.

For example, query the VLAN default configuration information:

```
3P@C(config)# show vlan default
```

```
VLAN ID: 2047
```

```
Vlan Name   : Default
```

```
Vlan Type   : Normal
```

```
Mac address : 00:05:3b:48:08:a6
```

Tagged Ports :

Untagged Ports : 0:1 0:2 0:4

7.3.5. Viewing FIB Table

Operation Guide

Execute the command `show fdb { [mac] <macaddr>*1 { [vlan] [<name>|<1-4095>]}*1 { [agingtime]}*1 { [permanent]}*1 { [port] [<portlist>]}*1 { [slot] [<0-15>]}*1` to view the FDB table. The table contains the information including: User MAC address, whether the MAC address of the opposite router is learned or not, whether the port and Vlan Name are correct or not, and fdb aging time.

Reference index

The information of the FDB address table is showed as follows:

```
3P@C(config)# show fdb
```

```
----- Begin of Mac Address Table Information (all)-----
```

```
Total 1 mac address entry showed.
```

```
Mac address      Port  Vlan name      Flags
```

```
-----
00:04:93:40:47:06 <3:23> default      Age
-----
```

```
----- End of Mac Address Table Information -----
```



prompt

The FDB entries to the CPU are not displayed.

7.3.6. Viewing the ARP Table

Operation Guide

You can execute the command `show arp {[<A.B.C.D>|permanent]}*1` to see whether the ARP has learned the MAC address of the corresponding IP.

Reference index

For example:

```
3P@C(config)# show arp
```

```
Begin to show arp table information
```

```
Physics Address  Ip Address      Type
```

```
Total 1 information (include dynamic and permanent)
```

```
00:01:02:28:49:06 20.1.1.2      dynamic
```

```
Total 1 information showed
```

```
End to show arp table information
```

7.3.7. Viewing the Route Information

Operation Guide

You can execute the command **show ip route** to query route information: Whether the route table is correct, whether the configured static route and OSPF/RIP route have been learned or not, and whether the route is selected correctly or not.

Reference index

For example:

```
3P@C(config)# show ip route
```

Codes: C - connected, S - static, R - RIP, O - OSPF

> - selected route, * - selected nexthop

```
S>* 0.0.0.0/0 [1/0] via 10.16.0.254, 3P@C
C>* 2.2.2.0/24 is directly connected, pppoe1
C>* 10.0.0.0/16 is directly connected, uplink
C>* 10.10.1.0/24 is directly connected, server2
S 10.10.1.0/24 [1/0] via 10.11.1.254 inactive
C>* 10.16.0.0/16 is directly connected, 3P@C
C>* 12.1.0.0/16 is directly connected, server
C>* 192.168.0.0/16 is directly connected, adsl
S>* 192.168.2.0/24 [1/0] via 192.168.1.3, adsl
```

7.3.8. Querying the System Running Time

Operation Guide

You can execute the command **show running-time** to query the system running time.

Reference index

The Current system time is consistent with Beijing time. The Running_time is correct.

For example:

```
3P@C(config)# show running-time
```

```
Running time is:0 days 1 hours 51 minutes 45 seconds
```

7.4. Handling Password Loss

Before equipment delivery, the default login user name is “admin”, the default password is “3P@C”, and the default password for entering the configuration mode is also “3P@C”. If the user modifies the above password, the user must bear the new password in mind. If forgetting the new password, the user can follow the procedures below:

Step 1: Power on the equipment, and press and hold <Space> to enter the BootROM menu. Select “g” (Boot an executable image) to skip over password check.

Step 2: Use the default user name “admin” and default password “3P@C” to log in.



prompt

To use the original configuration continuously, the user can go on to Step 3. To configure the user name and password again, ignore the following steps.

Step 3: Transfer the startup-config configuration file to the terminal equipment in the FTP/Xmodem mode.

Step 4: Modify the uploaded file. Replace the user management part of the uploaded configuration file with the following data:

```
user add admin login-password b58317da28dc92ba6c5509c317c633b8
```

```
user role admin ADMIN enable-password b58317da28dc92ba6c5509c317c633b8
```

Step 5: Download the modified configuration file to the Flash of the equipment

Step 6: Reboot the equipment.

CHAPTER 8

8. Port Maintenance

8.1. Checking the Optical Interface

Before connecting the optical interfaces at the transmitting end and at the receiving end through optical fibers, you need to check and test the optical interface to avoid data transmission error and component damage.

1. Check whether the types of the optical interfaces at the transmitting and receiving ends match each other

The type of the optical interface at the transmitting end must match that at the receiving end in the respects: Wavelength, optical fiber mode, transmission rate, and maximum transmission distance.

2. Check whether the type of the optical interface matches the type of the connected optical fiber

The type of the optical interface must match the type of the connected optical fiber in the respects: Wavelength, optical fiber mode, and connector.

3. Check the optical interface for short-distance optical fiber transmission

For short-distance optical fiber transmission, you can use the self-loop method to check the optical interface status. Connect the transmitting end with the receiving end of the optical interface through a well-matched optical jumper. If the LINK indicator is on, it indicates that the transceiving function of the optical interface is normal.

4. Check the optical interface for long-distance optical fiber transmission

When using the optical module supporting the long-distance transmission of more than 10 km, you need to measure the optical power at the receiving end with an optical power meter, and ensure that the measured value ranges between the overload point and receiving sensitivity.

- If the optical signal power at the receiving end exceeds the overload point at the receiving end, the optical interface at the receiving end will be damaged. Therefore, you need to use an optical attenuator (active) or flange (passive) in the line to reduce the optical signal power at the receiving end. You can adjust the attenuation value of the optical attenuator or flange, so that the optical signal power at the receiving end is within a reasonable range.
- If the optical signal power at the opposite end is less than the receiving sensitivity of the optical interface at the receiving end, it will cause data loss. If this problem occurs, you need to check whether the fiber connector contacts well or the optical interface is dirtied or damaged. If the problem still occurs, it may be caused by poor fiber link transmission and extreme transmission distance. Then, you need to consider using an optical amplifier or optical module supporting longer distance transmission.

The table below describes the attributes of different types of optical modules, and the range of receiving optical power.

Table 1-3 Parameter table on the modules of SFP optical interface

Type	Rate (bps)	Optical fiber mode	Maximum transmission distance	Optical connector type	Transmitting center wavelength (nm)	Transmitting optical power (dBm)	Receiving overload point (dBm)	Receiving sensitivity ((dBm)
SFP-SM-155M-15K	155 M	Single mode	15	LC	1,310	-15 ~ 0	-8	-28
SFP-SM-155M-40K	155 M	Single mode	40	LC	1,310	-5 ~ 0	-10	-34
SFP-SM-155M-80K	155 M	Single mode	80	LC	1,550	-5~0	-10	-34
SFP-SM-622M-15K	622 M	Single mode	15	LC	1,310	-15 ~ 0	-8	-28
SFP-SM-622M-40K	622 M	Single mode	40	LC	1310	-5~ 2	-8	-28
SFP-SM-622M-80K	622 M	Single mode	80	LC	1,550	-5 ~ 2	-8	-28
SFP-SM-1.25G-10K	1.25 G	Single mode	10	LC	1,310	-5~0	-3	-23
SFP-SM-1.25G-30K	1.25 G	Single mode	30	LC	1,310	-4 ~ 2	-3	-20
SFP-SM-1.25G-40K	1.25 G	Single mode	40	LC	1,310	-5 ~ 2	-3	-21
SFP-SM-1.25G-70K	1.25 G	Single mode	70	LC	1,550	-2~5	-3	-22
SFP-SM-1.25G-110K	1.25 G	Single mode	110	LC	1,550	0 ~ 5	-9	-30
SFP-SM-2.5G-15K	2.5 G	Single mode	15	LC	1,310	-10 ~ 2	-9	-18
SFP-SM-2.5G-40K	2.5 G	Single mode	40	LC	1,310	-10 ~ 3	-9	-19
SFP-SM-2.5G-70K	2.5 G	Single mode	70	LC	1,550	-10 ~ 3	-9	-19

Table 1-4 Parameter table on the modules of XENPAK optical interface

Type	Rate (bps)	Optical fiber mode	Maximum transmission distance	Connector Type	Transmitting center wavelength (nm)	Transmitting optical power	Receiving overload point (dBm)	Receiving sensitivity (dBm)
Xenpak-SM-10G-10K	10 G	Single mode	10	SC	1310	-8.2~0.5	0.5	-10.3

8.2. Checking the Status of the User Port

8.2.1. Querying the ADSL Port Status

You can query the ADSL port information by executing the commands below:

- **show port [portlist|all|active]**: Show the current information of the port
- **show port [portlist|all|active] adsl line-config**: Show the configuration information of the ADSL port

The first command is used to show the current information that is subject to update in real time. The second command is used to show configuration information that does not vary with the port link status.

For the **show port [portlist][all][active]** command, if the port is in the up state, the system will show some current information on the ADSL link: Current working mode, current upstream/downstream rate, current noise margin, and upstream/downstream attainable rate. If the port is in the down state, the displayed information will be of little use. For example (only one port 15:2 is in the up state):

```
3P@C(config)#show port active
```

Port:<15:2> 's Current Value Information

```
Link state           : Up      Port state           : enabled
Port Default VLAN ID : 2881   Port VLAN name       : dsl2881

Remote modem connection : YES
Service Mode          : G.dmt   Channel Mode         : Interleaved
DS Rate(Kbps)        : 8064    US Rate(Kbps)       : 1024
DS NoiseMargin(dB)   : 12.00    US NoiseMargin(dB)  : 7.00
DS Interleaved Delay(ms) : 16    US Interleaved Delay(ms) : 8
DS Attenuation(dB)    : 32.50    US Attenuation(dB)  : 23.5
DS Out Power(dB)     : 7.60     US Out power(dB)    : 12.40
DS Attainable Rate(Kbps) : 10400  US Attainable Rate(Kbps) : 1186
```

The parameters in the command are described below:

- Link state: Whether the port is in the link state (up or down)
- Port state: Whether the port is enabled or not. If the port is in the Disable state, the Link state must be down.
- Port Default VLAN ID: By default, each port belongs to the VLAN created by a system to isolate the ports. This item indicates the ID of the VLAN where the port is located.
- Port VLAN name: Name of the VLAN where the port is located
- Remote modem connection: Whether the port is connected with a modem. If it is “yes”, it indicates that the port is connected with a modem.
- Service Mode: The working mode of the port (g.dmt, g.lite, or t1.413)
- Channel Mode: The channel mode for port data transmission (Interleaved or Fast).
- DS Rate(Kbps): Actual rate in the downstream direction (Kbps)
- US Rate(Kbps): Actual rate in the upstream direction (Kbps)
- DS NoiseMargin(dB): Actual noise margin in the downstream direction, that is, signal-to-noise ratio. The greater it is, the better the link quality in the downstream direction is.
- US NoiseMargin(dB): Actual noise margin in the upstream direction, that is, signal-to-noise ratio. The greater it is, the better the link quality in the upstream direction is.
- DS Interleaved Delay(ms): Actual interleaved depth in the downstream direction. It is used for interleaved channels.
- US Interleaved Delay(ms): Actual interleaved depth in the upstream direction. It is used for interleaved channels.
- DS Attenuation(dB): Link attenuation in the downlink direction. It is a link parameter calculated from the ATU-R. The greater it is, the worse the link quality in the downstream direction.
- US Attenuation(dB): Link attenuation in the uplink direction. It is a link parameter calculated from the ATU-C. The greater it is, the worse the link quality in the upstream direction.

- DS Out Power(dB): Output power in the downstream direction. If the attenuation in the downstream direction is extremely large, the ATU-C will improve the output power in the downstream direction moderately to improve the signal-to-noise ratio, thus ensuring the link transmission quality in the downstream direction.
- US Out Power(dB): Output power in the upstream direction. If the attenuation in the upstream direction is extremely large, the ATU-R will improve the output power in the upstream direction moderately to improve the signal-to-noise ratio in the upstream direction, thus ensuring the link transmission quality in the upstream direction.
- DS Attainable Rate(Kbps): The estimated attainable link rate in THE downstream direction by the ATU-C according to the current link parameters.
- US Attainable Rate(Kbps): The estimated attainable link rate in upstream direction by the ATU-C according to the current link parameters.

For the **Show port [portlist|all|active] adsl line-config** command, whether the port in the up or down state, the system will display port configuration information: Upstream/downstream rate, working mode, channel mode, interleaved depth, and upstream/downstream target noise margin. For example:

```
3P@C(config)# show port 15:2 adsl line-config
```

```
-----
Port:<15:2> 's Configuration Information
Service Mode           :MultiMode Channel Mode           :Interleaved
DS MinRate (Kbps)     :32      US MinRate (Kbps)           :32
DS MaxRate (Kbps)     :8160     US MaxRate (Kbps)           :1024
DS Interleaved Delay (ms) :32      US Interleaved Delay (ms)  :16
DS TargetNoiseMargin (dB) :6       US TargetNoiseMargin (dB) :6
DS MaxNoiseMargin (dB) :12      US MinNoiseMargin (dB)    :0
ATUC LossOfFrame      :0       ATUC LossOfSignal         :0
ATUC LossOfLink       :0       ATUC LossOfPower          :0
ATUC Errored          :0
```

The parameters are described as follows:

- Service Mode: Working mode of the port. It can be multimode, g.dmt, g.lite, or t1.413. If it is configured as multimode, it indicates that the central office end and modem end can determine the actual working mode as g.dmt, g.lite, or t1.413 through negotiation.
- Channel Mode: Channel mode of the port. Its current value must be consistent with its configured value.
- DS MinRate(Kbps): The minimum rate in the downstream direction. It ranges within 1 – 8,160 kbps. It must be less than the maximum rate in the downstream direction (32 kbps).
- US MinRate(Kbps): The minimum rate in the upstream direction. It ranges within 1 – 1,024 kbps. It must be less than the maximum rate in the upstream direction.
- DS MaxRate(Kbps): The maximum rate in the downstream direction. It ranges within 1 – 8,160 kbps. It must be greater than the minimum rate in the downstream direction.
- US MaxRate(Kbps): The maximum rate in the upstream direction. It ranges within 1 – 1,024 kbps. It must be greater than the minimum rate in the upstream direction.
- DS Interleaved Delay(ms): The interleaved depth in the downstream direction. The actual interleaved depth in the downstream direction must be not greater than the configured value.
- US Interleaved Delay(ms): The interleaved depth in the upstream direction. The actual interleaved depth in the upstream direction must be not greater than the configured value.
- DS TargetNoiseMargin(dB): The target noise margin in the downstream direction. The actual noise margin in the downstream direction must be greater than this value.

- US TargetNoiseMargin(dB): The target noise margin in the upstream direction. The actual noise margin in the upstream direction must be greater than this value.
- DS MaxNoiseMargin(dB): The maximum noise margin in the downstream direction. The actual noise margin in the downstream direction must be less than this value.
- US MaxNoiseMargin(dB): The maximum noise margin in the upstream direction. The actual noise margin in the upstream direction must be less than this value.
- ATUC LossOfFrame: The frame loss threshold at the ATU-C side
- ATUC LossOfSignal: The signal loss threshold at the ATU-C side
- ATUC LossOfLink: The link loss threshold at the ATU-C side
- ATUC LossOfPower: The power loss threshold at the ATU-C side
- ATUC Errored: The errored second threshold at the ATU-C side

8.2.2. Querying the VDSL Port Status

You can query the VDSL port information by executing the commands below:

- `show port [portlist|all|active]`: Show the current information of the port
- `show port [portlist|all|active] vdsl line-config`: Show the configuration information of the VDSL port

The first command is used to show the current information that is subject to update in real time. The second command is used to show configuration information that does not vary with the port link status.

For the **show port [portlist|all|active]** command, if the port is in the up state, the system will show some current information on the VDSL port: Current upstream/downstream rate, whether the port self-negotiation is enabled, remote Ethernet speed (10 M/100 M), duplex mode (full/half), and whether flow control (flowctrl) is enabled.

If the port is in the down state, the above parameters will not be available and not be displayed. For example:

```
3P@C(config)# show port 14:19
```

```
-----
Port:<14:19> 's Current Value Information
```

```
Link state           : Up      Port state           : enabled
Port Default VLAN ID : 2834   Port VLAN name       : dsl2834
DS line rate(Mbps)   : 16.67   US line rate(Mbps)   : 12.5
Rt vdsl auto neg     : On      Rt ethernet speed    : 100 M
Rt ethernet duplex   : Half    Rt ethernet flowctrl : On
-----
```

The parameters are described as follows:

- Link state: Whether the port is in the link state (up or down)
- Port state: Whether the port is enabled or not. If the port is in the Disable state, the Link state must be down.
- Port Default VLAN ID: By default, each port belongs to the VLAN created by a system to isolate the ports. This item indicates the ID of the VLAN where the port is located.
- Port VLAN name: Name of the VLAN where the port is located
- DS line rate(Mbps): Downstream line rate (Mbps). It can be 1.04, 1.56, 2.08, 4.17, 8.33, 10.04, 12.5, or 16.67.
- US line rate(Mbps): Upstream line rate (Mbps). It can be 1.04, 1.56, 2.08, 4.17, 8.33, 10.04, 12.5, or 16.67.

- Rt vdsl auto neg: Setting of remote vdsl self-negotiation. “on” indicates that the self-negotiation function is enabled, and “off” indicates that the self-negotiation function is disabled.
- Rt ethernet speed: Remote Ethernet speed (10 M/100 M)
- Rt ethernet duplex: Remote Ethernet duplex mode (full/half).
- Rt ethernet flowctrl: Remote Ethernet flow control. “on” indicates that the function is enabled, and “off” indicates that the function is disabled.

For the **show port [portlist|all|active] vdsl line-config** command, whether the port is in the up or in the down state, the system will display the configuration information of the corresponding port: Upstream/downstream rate, self-negotiation setting, remote Ethernet speed (10 M/100 M), whether flowctrl is enabled, and duplex mode (full/half). For example:

```
3P@C(config)# show port 14:19 vdsl line-config
```

```
-----  
Port:<14:19> 's Config Information
```

```
DS line rate(Mbps)   : 16.67   US line rate(Mbps)   : 12.5  
Rt vdsl auto neg    : On      Rt ethernet speed    : 100 M  
Rt ethernet duplex  : Full    Rt ethernet flowctrl : On  
-----
```

The parameters are described as follows:

- DS line rate(Mbps): Downstream line rate (Mbps). It can be 1.04, 1.56, 2.08, 4.17, 8.33, 10.04, 12.5, or 16.67.
- US line rate(Mbps): Upstream line rate (Mbps). It can be 1.04, 1.56, 2.08, 4.17, 8.33, 10.04, 12.5, or 16.67.
- Rt vdsl auto neg: Setting of remote vdsl self-negotiation. “on” indicates that the self-negotiation function is enabled, and “off” indicates that the self-negotiation function is disabled.
- Rt ethernet speed: Remote Ethernet speed (10 M/100 M)
- Rt ethernet duplex: Remote Ethernet duplex mode (full/half).

Rt ethernet flowctrl: Remote Ethernet flow control. “on” indicates that the function is enabled, and “off” indicates that the function is disabled.

CHAPTER 9

9. Card Maintenance

9.1. Maintenance for System Control Board

9.1.1. Check

1) Checking running status of the system control board through the indicator

The corresponding status indicator in the front panel of the system control board is used to display the running status of the device, and it plays an important role in the fault analysis and location.

The rough position or cause of the fault can be found through the indicator status, and the indicator status is helpful for the next processing procedure. The indicator does not have the sufficient information, so it is usually used with the coordination of the alarm information analysis.

Check the system running status according to indicator description in the Table 9–1. When finding some exceptional cases, you should take some measures in time.



prompt

The maintenance personnel should pay more attention to the study of the indicator meaning, and have the rapid response capability when some faults occur to the system.

Table 9-1 Description of LED status of the system control board SMUB

Indicator	Flag	Color	Status	Description
System status indicator	RUN	Green	Off	The system does not run.
			Flashing	The system runs normally.
	ALM	Red	Off	The system runs normally.
			ON	The system has an alarm. When the device starts the self-inspection, this indicator will flash once, but it does not indicate an alarm.
Status indicator of the Ethernet interface	LINK	Green	Constantly on	When a stable link is built in the port, the corresponding indicator is constantly on.
			Off	No link is in the port.
	ACT	Green	Flashing	Data is being received/transmitted in the port
			Off	Data is not received/transmitted in the port



prompt

Note: The flashing frequency of the system indicator in the master system control board is faster than that in the standby system control board. The system indicator of the master system control board flashes three times per second, and the system indicator of the standby system control board flashes once per second.

2) Checking running status of the system control board through the command line

Maintenance item	Operation	Inspection
Check the system resource utilization	In the hidden mode (input the qpmz in the config mode to enter the hidden mode), enter the show cpuusage all command to check the CPU utilization.	Check whether the CPU utilization is very high (if the data is being saved or the Flash is being written, the high CPU utilization is normal, but this process does not last long). The normal CPU utilization of the service board is not higher than 20%.
	Use the command show cpuusage record to check the time when the CPU utilization reaches maximum value (in the hidden mode)	Check the CPU utilization in the historical durations.
Check the version of the system control board	show version all	If the version of the master system control board is not consistent with that of the standby system control board, the system running fault will happen.
Show the running time from the last reboot to now	show running-time (in the hidden mode)	Check whether an accidental master/standby switchover occurs to the system control board from the last reboot to now.
Check the system time:	show time (in the config mode)	The time here should be the standard Beijing time.

9.1.2. Hot Plugging

The device supports the hot plugging of the system control board in the normal running, and the configuration information of the original card is saved in the system in the plugging process.

- If the device is just configured with a system control board, the system will not run when you unplug the system control board.
- If the device is configured with two system control boards, the system will run normally when you unplug the standby system control board. If you unplug the master system control board, the master/standby switchover will occur to the device.

After unplugging a card from a slot, you cannot plug a new card immediately, and you should do it in a minute.



Note

During the system startup process, the hot plugging is not supported.

9.1.3. Master/Standby Switchover

The master/standby switchover refers to that the master/standby relationship switchover happens when the system control board is operated manually or some faults occur to it in the redundancy mode.

The master/standby switchover is a self-protection function of the system. When some faults occur to the master system control board, the master/standby is implemented automatically. In this way, the service is transferred to the standby system control board, and the system can continue to run.

To locate the faults, sometimes the manual master/standby switchover is needed. Check whether the master system control board runs normally or the master/standby relationship is coordinative by inspecting the switched system status. The detailed procedures of the manual master/standby operation are described below.



Note

The master/standby switchover causes the interruption of the service, so you must backup the system data before implementing the manual master/standby switchover. Otherwise, you may lose the data.

Procedures of the manual master/standby switchover

Steps	Operation	Inspection (display of the indicator and screen)
Step 1	To check whether the standby system control board runs normally, execute the command: show boardinfo	The system indicator flashes once per second.
Step 2	Backup the current configuration information of the master system control board to the standby system control board (with a service board, the configuration information can be saved to the standby board automatically): 3P@C(config)#save configuration.	
Step 3	To implement the master/standby switchover, execute the command: 3P@C(config)#systemswitch. The master/standby switchover needs about 20 seconds, and the service is interrupted temporarily in the later 30 seconds. Finally, the standby system control board takes over the service of the master system control board.	
Step 4	Connect the console cable to the Console interface of the current master system control board.	
Step 5	To check whether the master/standby switchover ends, and whether the master/standby system control boards work in the coordinative manner, execute the command show boardinfo in the current master system control board.	1. The system indicator of the current master system control board becomes the continuous flashing (three times per second). 2. The system indicator of the standby system control board flashes once per second.
Step 6	To check whether the system runs normally, and whether all service boards are registered normally and run stably after the switchover, use the Ping command to check the connectivity between the device and users, for example: ping 192.168.0.1.	1. The response status of each ping packet: If the response packet is not received in the time out status, "Request time out" is output. Otherwise, the number of the bytes of the data and the packet serial number, TTL, and response time of the response packets are displayed. The final statistics information includes the Min. values, Max. values and averages of the number of packets sent, number of response packets received,

Steps	Operation	Inspection (display of the indicator and screen)
		proportion of packets without response and the response time.

Comparing with other methods, the manual master/standby switchover does not provide the exact location for the cause of the fault. Due to the randomness of the running software, the fault phenomenon usually is not repeated in the short term after the switchover, and the nature of the fault is easily hidden, thus bringing the hidden trouble for security and running stability of the device. So this method is just used as the temporary emergency measure, and it should be used carefully when there is no other alternatives.

9.1.4. Reset

Reset is to reboot the part of the devices or all devices manually.

Reset of the system control board needs to be implemented under the following condition:

- After upgrading the software system, you need to reset the system control board to make the new system effective.
- When some unrecovered faults occur to the system, you can recover the system by resetting the system control board. Reset is used to judge whether the software runs confusedly, whether the program is suspended, and it is an extreme action taken when there is no other alternatives.

Reset method for the card:

Reset mode	Operation	Generation conditions
Soft reset	Use the reboot command to reboot the integrated device.	Upgrading
	Use the reboot {<0-15>}*1 command to reboot the card in the specified slot.	Troubleshooting



Note

You should enter the **save configuration** command to save the configuration information before resetting the system control board. Otherwise, you may lose the information.

Reset operation often causes interruption of the system service, even the system down, and brings the server negative influence to the daily operation of the system. So reset is just used in the occasion with a small influence and the backup measure. Usually reset is not recommended to locate the fault.

9.1.5. Replacing System Control Board

If the system control board needs to be replaced in the system running process, you should implement the following operation:

1) Replacement method of the master system control board

Steps	Operation	Inspection (display of the indicator and screen)
Step 1	To confirm the slot of the replaced master system control board, execute the command show boardinfo .	The system indicator flashes three times per second.
Step 2	To implement the master/standby switchover, see the details in the "steps for the	

Steps	Operation	Inspection (display of the indicator and screen)
	master/standby switchover”.	
 Note	In the card plugging process, you must wear the anti-static wrist strap, and guarantee that the other end of the anti-static wrist strap is connected to the ESD jack of the chassis. On the other hand, you should avoid contacting the circuit with your hands.	
Step 3	<p>Unplug the master system control board:</p> <p>a) Unplug the cables from all interfaces of the card.</p> <p>b) Unscrew the screws from the both sides of the card.</p> <p>c) Pull the extractors on the both sides of the card, and press them outward, thus unplugging the card from the connector of the back-plane of the chassis.</p> <p>d) Hold the front panel to unplug the card from the slot completely.</p> <p>e) Put the replaced card in the anti-static package.</p>	
Step 4	After unplugging the card, you should plug a new system control board in the void system control board slot in 60 seconds. Now, this system control board is a standby one (see the detailed installation steps in the hardware installation part).	
Step 5	To check whether the current standby system control board runs normally, execute the command: show boardinfo .	The system indicator flashes once per second.

2) Replacement method of the standby system control board

The replacement process of the standby system control board is simple. After the hot plugging, the system recovers, and then the replacement ends.

Steps	Operation	Inspection (display of the indicator and screen)
Step 1	To confirm the slot of the replaced standby system control board, execute the command show boardinfo .	The system indicator flashes once per second.
 Note	<p>1. You should guarantee that the console cables are connected to the Console interface of the master system control board.</p> <p>In the card plugging process, you must wear the anti-static wrist strap, and guarantee that the other end of the anti-static wrist strap is connected to the ESD jack of the chassis. On the other hand, you should avoid contacting the circuit with your hands.</p>	
Step 2	<p>Unplug the standby system control board:</p> <p>a) Unplug the cables from all interfaces of the card.</p> <p>b) Unscrew the screws from the both sides of the card.</p>	

Steps	Operation	Inspection (display of the indicator and screen)
	c) Pull the extractors on the both sides of the card, and press them outward, thus unplugging the card from the connector of the backboard of the chassis. d) Hold the front panel to unplug the card from the slot completely. e) Put the replaced card in the anti-static package.	
Step 3	After unplugging the card, you should plug a new system control board in the void standby system control board slot in 60 seconds (see the detailed installation steps in the hardware installation part).	
Step 4	To check whether the current standby system control board runs normally, execute the command: show boardinfo .	The system indicator flashes once per second.

9.2. Maintenance for Service Board

9.2.1. Check

The corresponding status indicator in the front panel of the service board is used to display the work status of the device or the card, and it plays an important role in the fault analysis and location.

The rough position or cause of the fault can be found through the indicator status, and the indicator status is helpful for the next processing procedure. The indicator does not have the sufficient information, so it is usually used with the coordination of the alarm information analysis.

Check the system running status according to indicator description in the following table. When finding some exceptional cases, you should take some measures in time.



prompt

The maintenance personnel should pay more attention to the study of the indicator meaning, and have the rapid response capability when some faults occur to the system.

Table 9-2 Description of the indicator of the VDUB service board

Indicator	Flag	Color	Status	Description
Status indicator of the VDUB	RUN	Green	On	Power on the system.
			Off	No power on or the system runs abnormally.
			Flashing	The VDUB runs normally.
	ALM	Red	Off	The VDUB runs normally.
			ON	The VDUB has an alarm.
Status indicator of the interface of the VDSL user	LINK	Green	Constantly on	When a stable link is built in the user interface, the corresponding indicator is constantly on.
			Off	This user interface does not connect the users.

Indicator	Flag	Color	Status	Description
	ACT	Green	Flashing	Data is being received/transmitted in the user interface.
			Off	No data is received/transmitted in the user interface.

Table 1-5 Description of the indicator of the ADUB service board

Indicator	Flag	Color	Status	Description
Status indicator of the ADUB	RUN	Green	On	Power on the system.
			Off	No power on or the system runs abnormally.
			Flashing	The ADUB runs normally.
	ALM	Red	Off	The ADUB runs normally.
			ON	The ADUB has an alarm.

Table 1-6 Description of the indicator of the ADUC service board

Indicator	Flag	Color	Status	Description
Status indicator of the ADUC	RUN	Green	On	Power on the system.
			Off	No power on or the system runs abnormally.
			Flashing	The ADUC runs normally.
	ALM	Red	Off	The ADUC runs normally.
			ON	The ADUC has an alarm.

9.2.2. Hot Plugging

The device supports the hot plugging of the service board in the normal running, and the original configuration information is saved in the system in the plugging process. Two situations happen when the user replaces the service board:

- If the type of the subsequently plugged card is the same as that of the unplugged card, the original configuration information will be recovered automatically.
- If the type of the subsequently plugged card is different from that of the unplugged card, the original configuration information will not be recovered automatically, and the user needs to configure the new card.

After unplugging the card from a slot, you cannot plug the card immediately, and you should do it in a minute.



Note

During the system startup process, the hot plugging is not supported.

9.2.3. Reset

Reset of the service board needs to be implemented under the following condition:

When some unrecovered faults occur to the system, you can recover the system by resetting the service board.

Reset method for the card:

Reset mode	Operation	Generation conditions
Soft reset	Use the reboot {<0-15>}*1 command to reboot the specified slot card.	Troubleshooting



prompt

You can implement the power-off reboot to the service board through the hot plugging.

9.2.4. Replacing Service Board

If the system control board needs to be replaced in the system running process, you should implement the following operation:

Steps	Operation	Inspection (display of the indicator and screen)
Step 1	To confirm the slot of the replaced service board, execute the command show version all or show boardinfo .	The system indicator flashes normally.
Step 2	Confirm that the service in the service board stops, and the service should be transferred to other cards or devices if necessary.	
	 <p>Note</p> <p>In the card plugging process, you must wear the anti-static wrist strap, and guarantee that the other end of the anti-static wrist strap is connected to the ESD jack of the chassis. On the other hand, you should avoid contacting the circuit with your hands.</p>	
Step 3	Unplug the service board: a) Unplug the cables from all interfaces of the card. b) Unscrew the screws from the both sides of the card. c) Pull the extractors on the both sides of the card, and press them outward, thus unplugging the card from the connector of the backboard of the chassis. d) Hold the front panel to unplug the card from the slot completely. e) Put the replaced card in the anti-static package.	
Step 4	After unplugging the card, you should plug a new service board in the slot of the original service board in 60 seconds (see the detailed installation steps in the hardware installation part).	

Steps	Operation	Inspection (display of the indicator and screen)
Step 5	To check the running status of the service board, execute the command show version all or show boardinfo .	The system indicator flashes normally.

If the type of the new card is the same as that of the original card, check whether the service on the interface of the new card is recovered. If the type of the new card is different from that of the original card, you should configure the service on the new card.

CHAPTER 10

10. Power Distribution System Maintenance

10.1. Checking Air-break Switch

The air-break switch is in the DC power distribution panel, with the overcurrent protection and short circuit protection functions. In the normal running process, the air-break switch is ON. When a large current passes through the air-break switch, the air-break switch switches from ON to OFF to cut off the power supply, so the device is protected.

Usually, you do not need to check the air-break switch. When the air-break switch switches to OFF suddenly, it indicates that there is something wrong with the power distribution system of the device or the device, and you should carefully look for the reasons that cause the short circuit protection before switching the air-break switch to ON.

To find the reasons, you should cut off the power supply of the device firstly, switch the air-break switch to ON, and use the multimeter to measure the input resistance. If the value of the resistance approximates to zero Ω , it indicates that there is the short circuit in the interior, and you need to locate each module. When plugging each module, you can find the short circuit module by judging the change of the resistance before and after the plugging, and you can switch the air-break switch to ON after the troubleshooting.

CHAPTER 11

11. Line Provisioning & Maintenance

11.1. Maintenance for Air Filter

The air filter consists of chassis air filter and power supply air filter. The air filter is used to prevent the dust from entering the chassis and power supply, so the device is protected.

11.1.1. Checking Air Filter



The power supply air filter should be checked and cleaned periodically to guarantee the fine ventilation and heat dissipation for the power supply. When the system has run for a certain time, the power supply air filter may be filled with the dust, and the ventilation and heat dissipation efficiency of the power supply may be lower than before. Now, you should dismount the plastic panel from the power supply, and clean or replace the air filter in the panel.

Check the air filter:

- Check whether the air filter is damaged.
- Check the blocking status of the air filter.

11.1.2. Cleaning and Replacing Air Filter

The air filter should be cleaned or replaced when the device has been used for a certain time, and the method is described as follows:

1) Dismount

Dismounting procedures of the air filter in the front panel:

Step 1	Press the plastic springs on the both sides of the plastic panel inward, and dismount the plastic panel.
Step 2	Put the plastic panel on the desk backward, and remove the sponge air filter from the panel.

Dismounting procedures of the air filter in the back panel:

Step 1	Unscrew the floating screws from the baffle of the air filter, and dismount the air filter baffle.
Step 2	Remove the sponge air filter from the panel.

2) Clean

Clean the dust from the air filter, wash it with the water, and it can be used after it is aired. On the other hand, you can use a new air filter to replace the original one.

3) Install

Step 1	Unfold the air filter, put it in the corresponding position, and attach the air filter to the fixing bar by pressing the four sides of the air filter.
Step 2	Install the front panel or the baffle of the air filter.

11.2. Maintenance for Fan Shelf

The fan shelf should be checked periodically to guarantee the fine ventilation and heat dissipation for the device, and the device can run stably.

11.2.1. Checking Fan Shelf

You can obtain the information through the alarm indicator status of the fan. The items to be checked:

Table 1-7 Description of the check items

Check item	Description	Fault diagnosis and measures
Status of fan alarm indicator	When the fan is abnormal, the ALM indicator of the fan module is on.	A fault occurs to the fan, and the fan should be replaced.

11.2.2. Replacing Fan Shelf

The fan shelf provides the heat dissipation function for the system. When a fault occurs to the fan shelf, the fan shelf should be replaced immediately. Otherwise, the device will be damaged due to overheating. The replacement method is described as follows:

1.1.1.55 Dismount the fan shelf

Step 1	You must wear the anti-static wrist strap, and the plug of the anti-static wrist strap should be plugged in the ESD jack on the front panel of the 19-inch cabinet with a height of 2.2 m.
Step 2	If you need a long time (exceeding five minutes) to examine and repair the fan module, you should cut off the power supply of the 3P@C 4450E system.
Step 3	Remove the screws at both ends of the fan module with a screwdriver.
Step 4	Press the left end of the white pulled handle in the center of the fan module panel, and then the pulled handle appears automatically, as shown in the figure below:

Figure 11-1 Schematic diagram of pulled handle operation

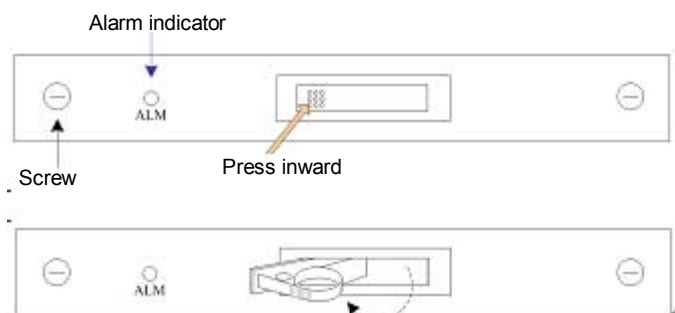

Step 5	Pull the fan module outward 10 cm by pulling the pulled handle with your right hand, and make the fan module leave the power supply socket of the interior sub-rack.
Step 6	If you dismount the fan module without cutting off the power supply, you must wait for a minute before the fan stops running completely.
Step 7	Hold the pulled handle of the fan module with your right hand, and pull the fan module out of the sub-rack completely by supporting the bottom of the fan module with your left hand.
Step 8	Put the dismounted fan module in a safe place.



Warning

When the fan shelf is dismounted, the fan may still run. Do not contact the fan vane. You should dismount the fan shelf only when the fan vane stops running completely.

1.1.1.56

Install a new fan shelf



Warning

If the fan module is replaced on site without cutting off the power supply, you should install the new fan module as soon as possible when the original one is dismounted. The new fan module should be prepared in advance and put in the safe place of the installation site.

Step 1	Installing the fan support: Use screws to attach the rack-mounting ears on both sides of the fan support to the cabinet, as shown in the figure below:
--------	--

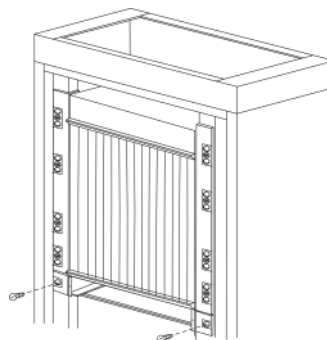
Figure 11-2 Installation of fan support**Step 2**

Installing the fan module: Plug the fan module into the fan support, and fasten the captive screws on the both sides of the support after putting the fan module in the corresponding position, as shown in the figure below:

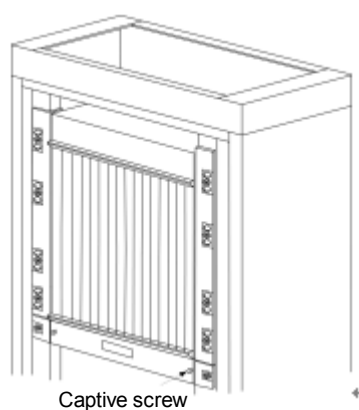
Figure 11-3 Installation of fan module

prompt

We suggest that you should not clean the fan shelf, and you should replace the fan shelf when the fan shelf is damaged or there is an alarm.

CHAPTER 12

12. Line Commissioning and Maintenance

12.1. Commissioning and Maintenance of ADSL Subscriber Line

12.1.1. ADSL Technical Parameters

1.1.1.57 ADSL Signal Frequency Range

ADSL splits the frequency band through the passive splitter, realizing the common transmission of voices and data on the twisted pairs, its signal frequency range is shown as follows:

Figure 12-1 Frequency range of ADSL

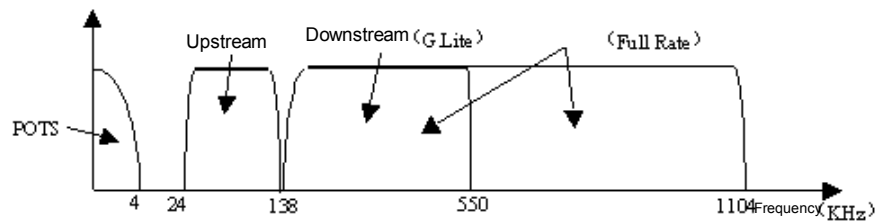

In this case:

- ADSL upstream signal frequency band: 26KHz—138KHz
- ADSL downstream signal frequency band: 138KHz—1104KHz
- Telephone audio frequency band: 300Hz— 3,400Hz

ADSL uses the Discrete Multi-Tone (DMT), and each carrier channel is relatively independent, the occupied frequency band width is 4.3125KHz, and each carrier can transmit the data of 0-15 bits in the signal transmission stage. Within the range of 0-1.1MHz, it is divided into 256 sub-carrier channels. The application and division of ADSL is shown in the figure below:

Figure 1-1 ADSL carrier channel application and division

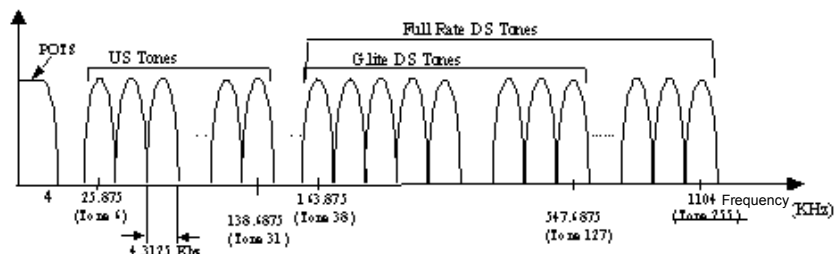

Here:

- US indicates Upstream

- DS indicates Downstream

1.1.1.58 Related Parameters of ADSL Voice Splitter

The copper wire bears the original voice signals and the new ADSL signals, because the voice signal takes the form of low-frequency signal, but ADSL takes the form of high-frequency signal. We can see from Figure 12-1, ADSL frequency range, the voice signal frequency band is 0 ~ 4KHz, but the ADSL signal frequency band is 24K ~ 1.1MHz. To prevent the high frequency signals from impacting on the voice signals and to ensure the quality of communication, the front end of the PSTN switch and the line of the subscriber line end are added with the voice splitter. The voice splitter is in fact a Low Pass Filter (LPF), which only permits the voice signals to pass and blocks the high frequency ADSL signals. The ADSL voice splitter has the following pass-band characteristics as shown in the figure below:

Figure 12-2 The pass-band characteristics of the ADSL voice splitter

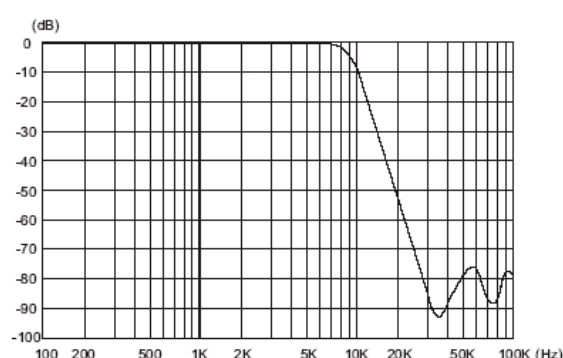

The voice splitter uses the passive devices, connected on the line in series, so it has a high reliability, but with the time elapse, it will also be of aged deterioration, mainly reflecting in the following respects:

- The increase of the DC loop resistance affects the connection rate of the ADSL line.
- Aging of capacitance affects the communication quality and the ADSL service.

The reference values of the main parameters of the voice splitter is shown in the table below:

Table 1-8 The reference values for the main parameters of the voice splitter

Test item	Condition	Reference index
DC resistance (Ω)	Line A and B	Short-circuit DC resistance = 25Ω
		Open DC resistance = $5M\Omega$
Reflection attenuation (dB)	300-500 Hz	$>14+2(f-3)$ dB
	500-2000 Hz	18dB
	2000-3400 Hz	$> 18-0.28(f-20)$ dB
Longitudinal balance (dB)	200-1000 Hz	58 dB
	1000-3000 Hz	53 dB

1.1.1.59 Conditions for ADSL central office end setting

The Central office terminal of ADSL is the equipment featured by easy management and operation, it can meet the demands for different service types through the setting of some constraint-based parameters, and achieve the better effect of line connection by the effective and reasonable configuration of the line parameters. The setting of ADSL parameters is shown in the table below:

Table 12-1 ADSL parameter setting table

Downstream configuration items	Parameter Setting	Upstream configuration items	Parameter setting
Maximum downstream interleaving delay (mS)	255	Maximum upstream interleaving delay (mS)	255
Target downstream noise margin (dB)	> = 6	Target upstream noise margin (dB)	> =6
Minimum downstream noise margin (dB)	0	Minimum upstream noise margin (dB)	0
Minimum downstream rate (Kbps)	32	Minimum upstream rate (Kbps)	32
Maximum downstream rate (Kbps)	8160	Maximum upstream rate (Kbps)	1024
Maximum downstream noise margin (dB)	31	Maximum downstream noise margin (dB)	31
Minimum downstream training noise margin (dB)	0	Minimum upstream training noise margin (dB)	0

The ADSL equipment produced by Harbor Network Co., Ltd provides the full-rate working mode (g.992.1/T1.413) and G.Lite according to the general ADSL standard in the industry. The default working mode of the equipment at the central office end is of multi-mode, it is determined by the Modem and the equipment at the central office end through negotiation.

The channel working mode is determined by operators basing on the demands of users, and for those users who have high requirements for delay such as VOD, interactive games and conference call; for such services as Internet accessing and data downloading, it is recommended to use the interleaving mode.

The related parameter setting is described as follows:

- Upon meeting the requirements, the upstream/downstream interleaving delay can be adjusted in ms, with the range of 0 to 255, and its default parameter configuration is: 24ms for downstream and 16 ms for upstream.
- The out-of-factory default setting of the upstream/downstream minimum noise margin is 0db, it is strongly recommended not to modify this value. If this value increases, part of the lines may be not able to be synchronized (the users with a line length of over 3km cannot be connected).
- The default configuration for the upstream/downstream maximum noise margin is 31db, in the case of good line situations, this parameter can be lowered to achieve the goal of reducing the transmission power.
- The default configuration of the target noise margin is 6db, and to lower the value of the target noise margin, the synchronization rate of the subscriber line can be increased. Change is not recommended.
- The minimum connection rate for upstream and downstream is 32Kbps, it is strongly recommended to keep it unchanged. If this value is too high, some lines may not be connected or connected unstably, especially when the distance of the line exceeds the 3km subscriber line.
- The maximum upstream/downstream connection rate is an optional value with the range of 32-896Kbps and 32-7616Kbps, and the specific value can be determined basing on the selection of operators. The current general way is to use different rates for charging in segments, and the upstream/downstream rate can be divided into multiple levels such as 128/512Kbps, 512/1024Kbps, and 512/2048Kbps.
- The default value of the minimum training noise margin is 0dB, it is strongly recommended to keep it unchanged.

Factors Affecting the ADSL transmission quality

■ Subscriber line attenuation

The attenuation of the ADSL subscriber line is an important factor to affect the ADSL commissioning, relevant to the length of lines. In the condition of the 0.4mm twisted pairs, the test data for the subscriber line attenuation is shown in the table below:

Table 12-2 ADSL subscriber line length attenuation table

Line attenuation Length of lines	Twisted pair		Adding 30m house parallel	
	Downstream attenuation (dB)	Upstream attenuation (dB)	Downstream attenuation (dB)	Upstream attenuation (dB)
1km	22.0	16.0	24.0	16.5
2km	40.0	28.5	44.5	30.0
3km	56.5	40.0	58.5	41.5
4km	63.5	51.0	65.5	51.5

The greater the degree of attenuation of the subscriber line is, the lower the connection rate of subscriber line becomes. The subscriber line will exceed the limit for commissioning the ADSL service when it exceeds a certain length and its attenuation becomes extremely high.

The above is the attenuation pair standard determined by the line length. In the same way, the Ministry of Posts and Telecommunications definitely provides the requirements on line attenuation (per kilometer) within different frequency bands, and different core diameters lead to different degrees of attenuation, for details, see the table below:

Table 12-3 ADSL line attenuation per kilometer within different frequency bands

f0 (kHz) Core diameter attenuation (dB)	40	60	80	120	150	300	1,024
0.32mm	11.40	13.01	14.38	15.12	16.80	18.13	33.50
0.4mm	8.29	9.34	10.05	10.87	12.10	14.78	27.30
0.5mm	5.99	6.85	7.06	7.77	9.00	12.18	22.50

■ Crosstalk interference

When there are multiple ADSL subscribers in the same cable, or there are HDSL subscribers, ISDN subscribers or the data transmission subscribers in other modes, the crosstalk interface would occur, and the characteristics of the channel will vary along with the number of such subscribers, enabling/disabling status and the changes of transmission rate. Based on the analysis on ADSL, HDSL and ISDN by means of transmission spectrum, the ISDN service can basically ignore the crosstalk interference from the ADSL service due to its low frequency band, and the ADSL equipment using the FDM technology can minimize the affects of crosstalk only against the ADSL line due to its separation of upstream/downstream frequency bands. The cross-talk interference mainly comes from the NEXT-NearEndCrosstalk (The cross-talk interference of the interference source on the receiver of the interference line pair in the case that the interference source and the receiver of the interfered line pairs are at the same end) of HDSL and the comprehensive FEXT-FarEndCrosstalk (The cross-talk interference of the interference source on the receiver of the interference line pair in the case that the interference source and the receiver of the interfered line pairs are far from each other) of many other ADSL line pairs.

The non-symmetric design of the ADSL rate allows a low rate of the upstream signal and low frequency band occupied, the crosstalk is less at the user end accordingly and the office end is easy to be controlled both in line connection and pair arrangement, which is favorable to control crosstalks. Crosstalk generally occurs to the connector of lines and the fault point of lines, and at the user end, generally the house line uses the parallel cable, to which the crosstalk is easy to occur.

To reduce the crosstalk interference, the subscribers with the approximate length of subscriber line should be placed on the same subscriber board or in the same pair cables; the ADSL subscriber line should be kept far from the ISDN subscriber line as much as possible.

- Noise

The noise are mostly background noises from lines, radio-frequency interference from the electrical equipment near the lines and such radio interferences as narrowband peak noise signals of AM broadcast, the affect of these interferences on lines is of long-term, and its impact on the transmission rate is reflected on the deterioration of SNR index of each sub-channel.

- Pulse noise

The pulse noise refers to the outburst discrete pulse interference, it has a large amplitude and the duration is far shorter than the time interval. The possible sources are the ringing signals from telephones, human-made electric sparks (auto ignition, power line), and large power transfer. The spectrum of the pulse noise is very wide, which can affect many sub-channels, but the amplitude at the frequency points is lowered accordingly, and its affect on the specific sub-channel is slighter than the noise of narrow frequency band. The pulse noise is hard to be tested because it occurs randomly, and at present, no specific index requirement is available. The test value within a period of time does not exceed this test pulse according to the test pulse noise model in the transmission loss of the ADSL standard.

- Telephone interference:

In addition to the interferences in ringing, off-hook and on-hook, the non-linearity of the telephone during conversation will also affect the data service. The test abroad shows that the non-linearity phenomenon does not occur when the power of the upstream signals sent by each telephone set should be lowered by 12db in average, and to some telephone sets, 24 db should be lowered. This means that the difference in the performance of the phone set will affect the quality of data transmission.

- Reflection interference

The bridged tap is a short line reaching somewhere, and the non-termination tap can emit energy, lower the strength of signals and become a noise source. There are at least 3 connectors (bridge point) from the Central office terminal to subscribers, the core diameter of each connector will change accordingly, and the cable loss leads to the abrupt resistance change, thus causing the loss of power reflection wave. It takes the form of echoes in the voice communication while in ADSL, the complex modulation mode is very easy to be affected by the reflection signals. Currently, there is no such equipment as testing the reflection source in the subscriber allocation cables in the frequency of 300KHz or above. At present, the echo cancellation technology is mostly used and it is excellent in the cancellation of echo effect from a certain source. When the signals, however, are reflected in many places, the echo cancellation is hardly effective.

12.1.2.ADSL Line Commissioning

1.1.1.60 Connection, Configuration and Test of Central office terminal

1) Connecting the ADSL equipment

Subscribers need to remove the original jumpers at the distribution frame upon applying for the commissioning of ADSL service, and connect the distribution lines and jumpers again basing on the situation of the ADSL equipment, to separate the traditional PSTN service from the data service, as shown in Figure 12-4.

Figure 12-3 ADSL distribution

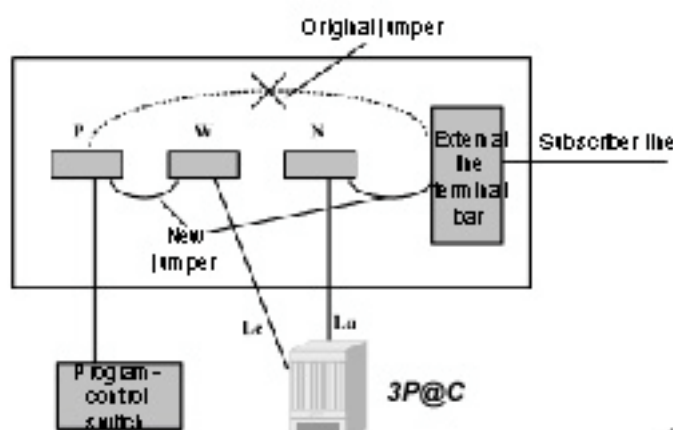

Here:

- P refers to the distribution frame of program-control switch
- W refers to the PSTN distribution frame of the ADSL equipment
- N refers to the subscriber line distribution frame for the ADSL equipment

2) ADSL parameter configuration

Based on the service types selected by subscribers, the ports related to the ADSL Central office terminal should be configured with the related parameters, which includes the ADSL working mode, channel working mode, the interleaving depth in the interleaving mode, upstream/downstream destination noise margin, upstream/downstream maximum/minimum rate. These parameters are relevant to the QoS and functions of subscribers.

3) Testing the ADSL connection parameters

After the ADSL equipment has finished with its jumper setting in the distribution room, the connection test needs to be done in the actual environment, to ensure the commissioning of the ADSL service.

The Harbor Network Co., Ltd sets the parameters as follows in the full configuration of the laboratory equipment based on the reality of lines.

- Target noise 6db
- Maximum downstream rate 8160Kbps
- Maximum upstream rate 1024Kbps
- Interleaving mode, upstream/downstream interleaving depth of 24 ms

And in the case of 0.4mm core diameter, the test reference data is as follows:

Table 12-4 ADSL line connection parameters

Cables Length (km)	Downstream rate (Kbps)	Upstream rate (Kbps)	Downstream noise margin (dB)	Upstream noise margin (dB)	Downstream attenuation Line downstream attenuation (dB)	Line upstream attenuation (dB)	Central office output Power output (dB)
1	7616	896	8	7	22	15.5	20
2	6624	896	6	6	40.5	28	21
3	3552	768	6	5	56.5	39.5	18
4	1184	448	7	6	63.5	50	15



prompt

1. The value of target noise margin (such as 12 db) can be raised to improve the stability of the line connection.
2. In the practice, the house parallel exerts a great impact on the connection rate, and this impact is especially obvious when the subscriber cable exceeds 2.5km, so it is recommended to reduce the application length of the house parallel.

1.1.1.61 Testing the ADSL Subscriber Line

There are certain requirements of the ADSL service commissioning on the subscriber lines:

- No loading coils should be placed on line.
- Better to use twisted pairs (paralleled iron wires and aluminium wires should not exceed 20 m)
- No special requirements are imposed on the line shielding
- In principle, no bridged tap should exist, even if so, its length should be less than 400m, and the distance of it from the two ends should not be less than 400m, and the quantity of it not exceed 2.
- The DC loop resistance is required not more than 1.1 k Ω
- The near-end protection ratio in terms of cable crosstalk should be more than 50db, while the far-end protection ratio is equivalent to the former plus the line attenuation.
- The normal line resistance is 100 Ω with the required error of not more than 10%.
- The idle channel noise is required not more than -55dB, that is, the mean noise power spectrum density is not more than -115dBm/Hz.
- Within the range of ADSL service frequency band of 26K-1104KHz, the longitudinal conversion loss is not less than 50dB, and in special cases, it is allowed to be more than 40dB.

Before the subscriber line is commissioned, the following checks should be made:

- First, check the distance between subscribers and the 3P@C 4450E equipment, if it is above 2km, the materials for the house line should be strictly chosen, and the parallels of aluminium or iron should not be used but the copper twisted pairs.
- Check the proper contact of the house lines.
- Check the proper insulation of the house lines.
- Check the existence of radio sources around the house lines, including transmitting station and arc welder.
- Check how many devices are connected in series and parallel on the house line, such as telephones, fax machines, charge registers, extensions of telephone, audio Modem, and IP dialer, and make the detailed records for locating problems in maintenance.

In addition, the subscriber line parameters should also be measured in respects of internal and external measurements:

- The internal measurement refers to the measurement on the distribution frame in the distribution room.
- The external measurement refers to the measurement of external lines.

Here, the internal measurement can be done simply by means of Modem or the handheld terminals which is directly connected to 3P@C 4450E for test, and the status of lines can be judged by viewing the actual connection parameters. Or the multimeter is used to measure the line parameters, including voltage, capacitance and resistance. The detailed methods are as follows:

Voltage measurement

Disconnect the equipment from the tested lines, and select the DC voltage gear of the multimeter to measure the voltage of -48V and BGNL line from the external connecting terminals, the value after measurement is the DC voltage of the subscriber line.

Select the AC gear of the multimeter to measure the AC voltage between Line A and B separately, the AC voltage between Line A and the ground and the AC voltage between Line B and the ground.

Capacitance measurement

Disconnect the tested lines from the switch, and select the capacitance measurement gear of the digital multimeter by connecting it with the external terminal, A and B lines, to measure the capacitance between Line A and Line B, that is, the capacitance C a-b between Line A and Line B. In the same way, the capacitance of Line A to the ground, C a-gnd and the capacitance of Line B to the ground, C b-gnd.

Resistance measurement

Disconnect the tested lines from the switch, and select the resistance gear of the digital multimeter by connecting it with the external terminal, A and B lines, to measure the insulation resistance between Line A and Line B, that is, the insulation resistance R a-b between Line A and Line B. In the same way, the insulation resistance of Line A to the ground, R a-gnd and the insulation resistance of Line B to the ground, R b-gnd.

Similarly, the loop resistance of the subscriber line can also be measured, and the way is to loop at remote end, and connect Line A with Line B shortly, and disconnect the local A and B lines from the switch; use the digital multimeter to connect the local A and B terminals, and select the resistance gear of the multimeter to read the measurement resistance, that is, the tested DC loop resistance. The table below gives the reference values of the DC loop resistance for subscriber lines with different core diameters per kilometer:

Table 12-5 DC loop resistance for subscriber lines with different core diameters per kilometer

Core diameter (mm)	0.32	0.4	0.5
Loop resistance (Ω /km)	470	280	190

In practice, it may be the subscriber line of mixed core diameters, in this case, we should give it a comprehensive consideration, the DC loop resistance of subscriber line should not be more than 1.1 k Ω . For the external measurement, some parameter index of the external lines can be tested by means of 112 test terminal.

Through the measurement of the actual subscriber line, a reference table will be given for guiding the commissioning of the ADSL service, and the details are shown in the table below:

Table 12-6 Line test reference table

AC voltage (VAC)	V a-b	V a-gnd	V b-gnd	
	0V	0V	0V	
DC voltage (VDC)	V a-b	V a-gnd	V b-gnd	
	0V	0V	0V	
Resistance (Ω) core diameter: 0.4mm	R a-b loop resistance	R a-gnd	R b-gnd	R a-b insulation resistance
	280 Ω /km	>5M Ω	>5M Ω	>5M Ω
Capacitance (μ F) core diameter: 0.4mm	C a-b load open-circuit	C a-gnd	C b-gnd	C a-b on-hook
	45-55nF/km	30-40nF/km	30-40nF/km	>0.35 μ F

Based on the above table, we can make an analysis on the line status:

- Judge whether there is tap of power line by viewing the AC voltage.
- Judge whether there is swinging cross by viewing the DC voltage, V a-gnd and V b-gnd.
- Judge the insulation of Line A and B -ground by viewing the resistance values, R a-gnd and R b-gnd, and the test value of the actual line may not reach more than 5M Ω as required by the national standard. The reason is for this is mainly the impact of the line environment, for example, regional climate difference leads to the difference in line status, or different humidity conditions, poor water-releasing performance of the junction box, the resistance of R a-gnd and R b-gnd is lower than 200k Ω which is the lowest standard for commissioning the ADSL line, so the ADSL service is easy to be interrupted.
- The open line test requires to inform users to remove all the devices on the subscriber line for measurement. C a-b is 45~55nF per kilometer, and the normality of the C a-b value can be

judged basing on the length of loop. The value for commissioning the ADSL service line is lower than 170nF.

- View the value of C a-gnd and C b-gnd, requiring the difference between these two should be less than 5%, the consistency between the C a-gnd and C b-gnd values reflects the quality of the parameters for Line A and B -ground balance. If these two values are greatly different, the connection rate and stability of ADSL would be affected.
- R a-b insulation resistance should be more than 200kΩ in normal condition, if less than this value, the subscriber line may suspend other devices, such as charge register, IP dialer and inquiry station dialing limiter.



Note

Before commissioning, the parameters of subscriber lines should be tested to ensure the commissioning of the ADSL service.

1.1.1.62 Connection, Testing and Commissioning of User End Devices

1) Connection splitter

The ADSL service is the traditional voice and data services run on a twisted pair, requiring the installation of splitter at the user end to separate voice from data. The correct installation of ADSL splitters is a key step in the process of ADSL service commissioning.

The house line should be first connected into the Line port of the ADSL splitter, and all the audio devices should be connected to the Phone port of the splitter and ADSL Modem to the Modem port.



Note

The practice of connecting to any voice devices before the Line port of the splitter should be prohibited, or else, Modem cannot work normally.

The method for correctly connecting the splitter is shown in the figure below:

Figure 12-4 Connection of splitters

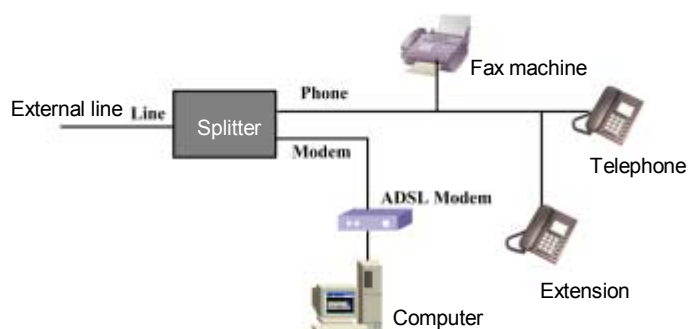

Note

Some Modems are in-built with splitters, and the connection of the ports can be done as shown in the figure above.

2) Testing and Commissioning of Modem

First, the test can be done by directly connecting the Modem from the junction box of users (If there is no power supply, the handheld Modem is needed), and by comparing the connection parameters of Modem, we can judge the normality of backbone cables and the wire-bonding of the distribution frame. Parameters are as follows:

Table 12-7 ADSL service line reference table

Core diameter = 0.4mm						
Line length		1,000m	1,500m	2,000m	2,500m	3,000m
Maximum connection rate (Kbps)	Downstream	6,144	6,144	4,928	3,168	2,016
	Upstream	640	640	640	608	576
Line attenuation (dB)	Downlink	18	27	36	43	48
	Upstream	12	18	24	30	36
Core diameter = 0.32mm						
Maximum connection rate (Kbps)	Downstream	6,144	5,408	4,096	1,920	816
	Uplink	640	640	616	576	528
Line attenuation (dB)	Downlink	22	33	42	50	56
	Upstream	14	21	28	35	42

The results of actual line measurement may be somewhat different (the line length is known), the attenuation differs by 3~4db, which should be within the permitted range. If differing too much, the line connector may exist problems, and need to be checked. And the case of normal attenuation measurement but too low connection rate may occur, this can be the result of too much line noise. If the upstream rate is low, there may be interferences of the nearby pairs to the ISDN service; if the downstream rate is low, the poor balance of peripheral pairs may be the reason, which leads to much noise. If the connection rate of Modem is basically matched with the reference table, users can commission the ADSL service.

In addition, the correctness of VPI/VCI setting and protocol encapsulation format of Modem is correct.

1.1.1.63 Recording the User Information and Relevant Data

For the convenience of the later operation maintenance, the user information and the data for the initially commissioned line connection. For details, see Table 12-9 and 12-10:

Table 12-8 Broadband service user information record table

Name		User address			
Certificate number		Modem serial No.			
Multiplexing telephone		Service type	ADSL	VDSL	Others
Contact		User type		Application for bandwidth	Upstream
				Downstream	
VPI/VCI		Port		Position of distribution frame	
Distribution records	Serial No. for external line vertical board position		Serial No. for the internal line P cross board position		
	Serial No. for the internal line N cross board position		Serial No. for the internal line W cross board position		
112 external line test data	AC voltage (VAC)	V a-b	V a-gnd	V b-gnd	Length of loop
	DC voltage (VDC)	V a-b	V a-gnd	V b-gnd	
	Resistance (Ω)	R a-b loop resistance	R a-gnd	R b-gnd	R a-b insulation resistance
	Capacitance (uF)	C a-b load open-circuit	C a-gnd	C b-gnd	C a-b on-hook

Table 12-9 ADSL setting parameters and connection parameter record table

Set the restraint parameters					
ADSL Working mode	G.dmt	[]	Channel working mode	Fast	[]
	G.lite	[]		Interleaved	[]
	T1.413	[]	Interleaving depth	Up(ms)	
	Multimode	[]		Down(ms)	
Target noise margin (dB)	Upstream		Minimum noise margin (dB)	Upstream	
	Downlink			Downstream	
Maximum rate	Upstream		Maximum rate	Upstream	

	Downstream		Downstream	
Actual connection parameters				
Current working mode of lines	G.dmt: []	Channel working mode		Fast: []
	G.lite: []			Interleaved:[]
	T1.413: []	interleave d delay	Upstream (ms)	
	Multimode:[]		Downstre am (ms)	
Downstream connection rate (Kbps)		Upstream connection rate (Kbps)		
Downstream noise margin (dB)		Upstream noise margin (dB)		
Downstream line attenuation (dB)		Upstream line attenuation (dB)		
Downstream output power (dB)		Upstream output power (dB)		

12.1.3.ADSL Line Maintenance

1.1.1.64 ADSL Users' Common Faults and Handling

The common faults reported by the ADSL users can be divided into five categories as follows:

- Unable to make calls and access the Internet.
- Able to make calls but cannot access the Internet.
- Able to access the Internet, but the speed for accessing is slow.
- Unstable Internet accessing, and often being disconnected.
- Others. Other faults in addition to the above four kinds of fault. Internet accessing is possible but calls cannot be made, or noises exist in telephone.

Specific description:

- Unable to make calls and access the Internet.

In general, it is the fault of lines, which should be reported to the 112 test terminal. First exclude the line failure and check whether the Internet accessing is possible after the telephone can be normally used.

- Able to make calls but cannot access the Internet.

The cause for failure may be related to all the devices or links in the broadband network structure. The causes for failure can be further located by obtaining the information, such as the status of the Modem (RTU) indicator and operation and setting of the user computer operation. The detailed procedures are as follows:

1) Inquiry and record the model and indicator status of Modem.

The English abbreviation IDs of the RTU indicator for different models may vary, but in general, the Ethernet port indicators, ADSL connection indicator and power indicator.

2) Judge the faults based on the status of indicators.

Power status of power indicators

If the RTU power indicator is off, it indicates that the RTU power supply has not been properly connected or is the result of RTU failure; if the RTU power supply is confirmed to be normal, but all the RTU indicators are not on, it surely is the RTU failure. If the power supply is properly connected, and the RTU power indicator is on, but the Internet accessing is still impossible, the following analysis can be continued.

Status of the ADSL LINK Indicator

The green ADSL LINK (WAN for some Modems) indicator is constantly on, indicating the normal connection of WAN, that is, the normal connection of the ADSL line. The ADSL LINK indicator is off, indicating Modem works abnormally, and it should be powered on and connected again to see whether normal work is possible.

The ADSL LINK indicator is flashing intermittently, indicating that the ADSL line is being connected or unable to be connected. This is the problem of lines. First check whether the splitter is installed in the proper position, the telephone wire to the splitter is properly connected, and check the contact of the telephone connectors, and whether the telephone line passes such interference sources as TV set or speakers, if so, it must be kept far away from them, and you should report to the 112 test terminal for checking the external lines if the problem still exists.

Status of the LAN LINK Indicator

The green or orange indicator of ADSL LINK (LAN for some Modems) is constantly on, indicating the normal connection of the Ethernet. Green indicates a data transmission rate of 10Mbps, while orange indicates a data transmission rate of 100Mbps (but different Modems can be defined differently, for details, see the use manual of Modem). If LAN LINK indicator is not on, it indicates the improper connection of RTU with the network adapter of computers, or the computer network adapter failure (the normality of 2 indicators of the network adapter can be the reference). After confirming the proper connections, check the normality of the network adapter of the computer, and you should install the driver or change the network adapter if necessary.

Status of the ADSL ACT Indicator

The ADSL ACT indicator flashes, indicating that the external network between the computer and RTU is transmitting data, and the communication is normal.

Status of the LAN ACT Indicator

The LAN ACT indicator flashes, indicating there is data traffic on the Ethernet.

3) Locating and handling the problems of user end devices, user application or upstream ports.

If the indicators of the above Modem show the normal status, but the user still fails to access the Internet, it can be said to be the problems of user end devices, user application or upstream ports. The location and troubleshooting work can be continued according to the following methods:

1} In general, the users are accessed in PPPoE mode. First check the possibility of reaching the PPPoE authentication stage, if so but fails to authenticate, or the normal accessing the Internet after the successful authentication, the problems may lie in the upper layer of the access server. Next, the data management office should be responsible for checking other ports.

2) If the PPPoE dialing cannot be normally started, it is generally the problem of user dialing software, and install the software again and to give it a try after correctly setting the computer.

3) The user computer has the following typical problems for application:

- TCP/IP attribute setting error. The IP address should be “automatically obtaining the IP address”.
- Whether the dialing account format and the password are correct.
- Improper installation of dialing software.

4) PPPoE authentication is successful, but the Internet accessing is impossible, you may change to other websites, if they all cannot be accessed, the problem can lie in the access server. or lie in the website.

- Able to access the Internet, but the speed for accessing is slow.

1) Whether the rate of Internet accessing is fast sometimes and slow at other times, or slow all along.

If it is slow all along, and the rate is below 500Kbps(60KByte ps), it is generally the problem of lines. The data office NMS can be used to view the physical connection rate, and whether the ports have the limited rate and to what extent the rate is limited. If the physical connection rate is high, it cannot be the problem of lines, and no expansion of the broadband access server port may be the cause. In addition, if the rate for accessing the Internet has reached up to the port limit rate, the problem may lie in the limited port rate.

2) The line is quite short, but the rate for accessing the Internet cannot reach up to 2Mbps at all, first check the physical connection rate of this port through the data office NMS and the line attenuation. If the physical connection rate reaches up to 2Mbps or the rate limit, it shows the line is normal. In this case, check the setting of interleaving depth. If the interleaving depth is 64, the TFTP files can be transmitted at a rate of 1.5Mbps(180KBps) at most due to the restriction of TCP/IP.

3) The physical connection rate of the port can be queried through the data office, and if the physical connection rate is quite different from the file transmission rate, it is generally the bottleneck problem of upstream interface node rate if the physical connection rate is normal.

4) Long lines, much line noise and poor quality of house lines may be the cause of the slow Internet accessing.

- Able to access the Internet, but unstable, and often being disconnected.

This problem is often the result of too large high-frequency attenuation due to poor quality of lines or too long lines, too much line noise and poor contact of lines, the following points can be the reference for problem judgment:

1) First make a judgment as to whether the line exceeds 3km, if so, the line may be too long, or this problem still exists in the ADSL subscribers around.

2) Check whether the front end of Modem is connected to other voice devices, such as IP dialer, which should be removed.

3) Check whether the splitter is installed in the proper position. It is recommended to install it to the entrance of the telephone line.

4) In disconnection, check whether a call is made or other electrical devices are used. Judge whether there is any interference equipment.

5) Check the connectors of the house line and the plugs of the telephone wires, the aging of connectors and the damages to the socket springs. Check the quality of house lines.

6) Check the connection configuration parameters and the connection parameters conditions of the related ports on the DSLAM equipment.

7) Use the 112 to test the external lines in terms of length and attenuation, and analyze the test data.

- Others

The faults rather than the above four are described as other faults, and make a detailed record about them. For example, you can access the Internet but cannot make calls, which is generally the problem of line connectors. This kind of faults may be the problem of house lines or ADSL connection. The specific description is as follows:

1) Common faults of house lines

The ADSL service faults generally occur to the house line, the following are the typical faults:

(1) Improper contact between the line plugs and the line socket, or insufficient elasticity of the spring steel wires or it is deviated.

(2) The sockets of Line A and B become damp (especially in South with much rain), which leads to the lowering of the insulation resistance of Line A and B or short-circuit -ground.

(3) The connectors of Line A and B have not wrapped properly with insulation tape, and frequent short-circuits occur due to the external force.

(4) The splitter is not properly used, and its external interfaces are connected with telephone extensions, fax machines, IP dialers and audio Modems in series and parallel.

(5) When the subscriber line exceeds 2.5km, the house line uses the too long parallels of aluminium or iron.

(6) The house line passes the radio sources that affect the ADSL service transmission.

2) Common faults in ADSL connection

The problem of the ADSL connection is reflected by users' incapable of normally accessing the Internet. The causes and handling mode for this problem boils down to the following aspects:

(1) The subscriber line failure: It is recommended to check short circuits or circuit break of the telephone set.

(2) Modem failure, the power-on/off is used to judge whether the Modem can be normally started.

(3) Check the Modem indicator, if the Link indicator is off, it indicates the broken connection of Modem.

(4) Check the correctness of the in-door splitter connection, and the addition of audio devices and telephone extensions at the front interfaces of the splitter.

1.1.1.65 Case Analysis

1) Synchronization of subscriber ADSL Modem impossible

It is one of the common problems in the ADSL application, and there are many causes for this. Including:

- Quality of ADSL Modem
- Irrational wiring
- Environmental factors
- Line fault
- Office equipment configuration

The faults are generally removed in the way of segmental test, and the test instruments are used if necessary.

Case Background

In the implementation of ADSL number allocation, the ADSL Modem of a subscriber cannot be synchronized all along, but the same Modem can be normally synchronized in the 0-kilometer test. The home of the subscriber should be 2.6km or so away from the office end equipment.

Fault symptom

Correctly connect the splitter, telephone sets and Modems, and the Modem cannot be synchronized.

Analysis and troubleshooting:

Step 1	The 0km test is done on the central office distribution frame, and this Modem can be normally synchronized. So, the Modem should be of no problem.
Step 2	In testing the telephone, calls can be normally made. There should be no problem to the splitter, and it is installed in the proper position.
Step 3	The environment for installing Modem indoors should be excluded with high-power devices, such as refrigerator, monitor and TV sets.
Step 4	In checking the house line, it is found that it is the parallel and aged seriously. And after the further investigation, the house parallel is found to be the common wires with a length of 80m or so. The line is exposed under the sun, and the junctions of the connector are not so firm. It is the result of unreliable house lines after analysis. The high frequency attenuation of the parallel is great and the connection quality is also poor, which leads the ADSL signal not to be normally borne.
Step 5	Change the house line into the copper twisted pair of 0.4mm, and everything becomes normal after the remaking of connectors for each part, and Modem can be synchronized and calls can be normally made. This problem is solved.

Summary

The problem of house line quality is one of the common faults of external line.



Note

The synchronization of ADSL Modem should be achieved in the respect of Modem, backbone, house line, splitter, routing method and peripheral environment, and a correct conclusion can be obtained with the above factors excluded.

12.2. Commissioning and Maintenance of the VDSL Subscriber Line

12.2.1. VDSL Technical Parameters

1.1.1.66 VDSL Signal Frequency Range

The VDSL access equipment of Harbor uses the VDSL system based on the IP transmission mode, and the modulation mode is QAM, and the used signal frequency range is shown in the figure below:

Figure 12-5 VDSL frequency range

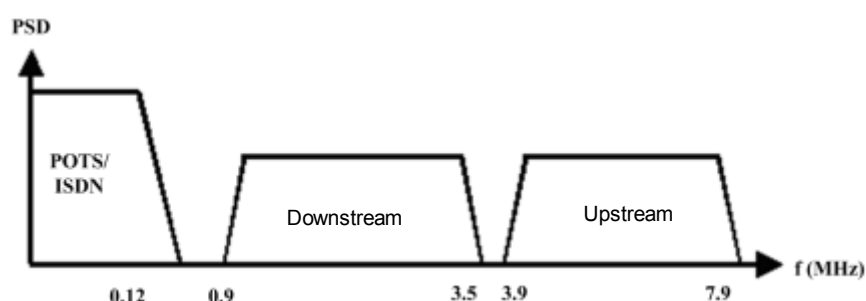

prompt

The spectrum of VDSL, POTS, ISDN, HDSL, SDSL, and ADSL is not cross-connected. The VDSL service can co-exist with ADSL in the same wire bundle.

1.1.1.67 Key Technical Parameters for VDSL (Terminal resistance, PSD, SNR)

- On the full band of VDSL, the output resistance of the equipment is 100Ω , and this resistance can be matched with different types of non-shielded twisted pairs of most access networks.
- The downstream and upstream signal powers are 10dBm(10mW).
- The total maximum transmission power as required by the national standard does not exceeds 14.5dBm.
- PSD (Power Spectral Density): **When** the frequency is any value between 25kHz and 12MHz, the transmission power spectrum density value of the upstream signals cannot exceed -53dBm/Hz; the transmission power spectrum density value cannot exceed -60dBm/Hz when the downstream signal is between 138kHz-3.75MHz; the transmission power spectrum density value cannot exceed -53dBm/Hz -60dBm/Hz when the downstream signal is between 8.5MHz-12MHz.
- SNR (Signal Noise Ratio, that is, the ratio between signal power in the channel and the noise power): the SNR value reflects the quality of the VDSL signal transmission on the line.

1.1.1.68 Factors Affecting the VDSL Transmission Quality

The following factors can affect the transmission quality of the VDSL service:

- Line length

The line length determines the attenuation and delay of transmission, which is the most important factor to determine the VDSL transmission distance. In practice, other possible factors should be combined for consideration. The following only lists the experience value for reference:

In the environment of cells, the 0.4mm cable can be used for commissioning 1km/ symmetry/12.5M;

In the central office, the 0.32mm cable can be used for commissioning 1km/non-symmetry/downstream 4.17M and upstream 1.56M.

■ Insulation resistance

Usually, the insulation resistance between the insulation wire and the ground, and between shielded insulation wires should not be less than 30M.

■ Crosstalk interference

Since the transmission distance of VDSL is shorter than ADSL, and the power is low, NEXT (Near End Crosstalk) can be ignored, so the crosstalk interference mainly refers to FEXT (Far End Crosstalk). The PBO (Power Backoff) of VDSL mechanism can automatically adjust the transmission power according to the size of SNR, thus making the crosstalk the smallest.

■ Line attenuation

The line transmission attenuation can result in the weakening of signals, thus communication cannot be established or a large number of outburst error codes can occur in the transmission process. The main factor to affect the attenuation is the cable length, core diameter and the quantity of pairs in the harness.

■ Pulse noise

The pulse noise refers to the outburst discrete pulse interference, it has a large amplitude and the duration is far shorter than the time interval. The source of pulse noise may be the ringing signals of telephone and the human electric sparks (Such as auto ignition, electric power), the power switching of large power (for example, the telephone lines are paralleled with the electric power in the elevator well). The pulse noise is hard to be tested because it occurs randomly, and at present, no specific index requirement is available. VDSL provides the interleaving function, to effectively avoid some pulse noises, which can reach up to 300ms at most, while 90% of the pulse noise can last for less than 200ms.

■ Idle channel noise

This is the background noise, a main parameter for calculating SNR.

The factor to affect VDSL connection rate is the attenuation of the transmission distance to the upstream high frequency band. as shown in the table below:

Table 12-10 The minimum SNR value for the rates (for reference)

1.56M,1.04M	1.04 M	QAM4	19 dB
12.5M,8.33M,4.17M, 2.08M	8.33M,4.17M,2.08M	QAM16	25 dB
X	12.5 M	QAM64	31 dB

Analyzing based on the above table, the low rate does not necessarily mean the low requirements for line quality, but is determined by the QAM points. That's why the connection of the symmetric 2.08M/2.08M is not so stable as the non-symmetric 4.17M/1.56M (the default rate mode) in the poor condition of lines, because the minimum SNR of the upstream 2.08M is 25dB, higher than 19dB of the upstream 1.56M.

- Echo

The echo is the reflection wave caused by the unbalance of line resistance or the bridge equipment in the line. The echo would result in the loss of signal energy, and extra interference the line, especially greatly affecting the full-duplex service transmission quality of broadband. The changes in the Line A-B capacitance and Line A/B-ground capacitance and inter-line insulation resistance and ground insulation resistance will lead to the change of line resistance to generate echo, and cause attenuation and interference to the VDSL signal. The use of resistance matching technology and the echo elimination circuit can help reduce the affect of echo. The resistance of VDSL to the transmission line is required to be the 100Ω pure resistor.

12.2.2.VDSL Line Commissioning

1.1.1.69 Connection, Configuration and Test of Office End Equipment

1) Connection of the VDSL equipment

Subscribers need to remove the original jumpers at the distribution frame upon applying for the commissioning of VDSL service, and connect the distribution lines and jumpers again basing on the situation of the VDSL equipment, to separate the traditional PSTN service from the data service, as shown in Figure 12-7.

Figure 12-6 VDSL distribution

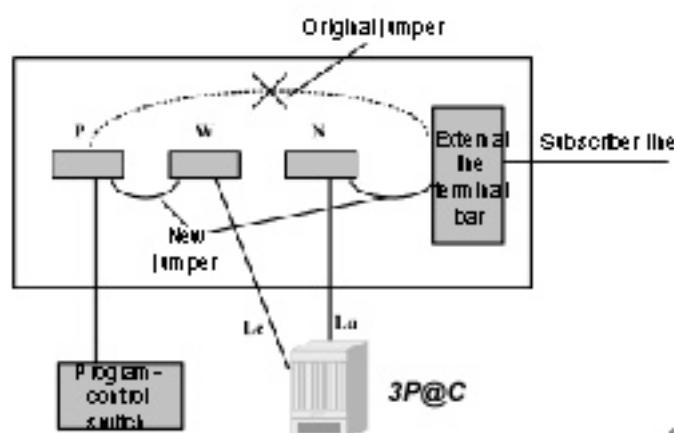

Here:

- P refers to the distribution frame of program-control switch
- W refers to the PSTN distribution frame of the VDSL equipment
- N refers to the subscriber line distribution frame for the VDSL equipment

2) VDSL parameter configuration

Based on the service types selected by subscribers, the ports related to the VDSL office end equipment should be configured with the related parameters, including the VDSL upstream/downstream rates, auto-adaptation mode, Ethernet rate and duplex mode. These parameters are relevant to the QoS and functions of subscribers.

3) Testing the VDSL connection parameters

After the VDSL equipment has finished with its jumper setting in the distribution room, the connection test needs to be done in the actual environment, to ensure the commissioning of the VDSL service.

1.1.1.70 Testing the VDSL Subscriber Line

There are certain requirements of the VDSL service commissioning on the subscriber lines:

- The DC loop resistance is required not more than 300 Ω .
- The nominal resistance (the AC resistance between twisted pairs) of lines is 100 Ω , and the error is required to be not more than 10%.
- The lines cannot be attached with loading coils, and the practice of attaching the loading coils on the subscriber line is rare in China.
- Better to use twisted pairs (paralleled iron wires and aluminium wires should not exceed 20 m).
- There are no special requirements for the shielding of lines; in principle, there should not exist the bridged tap.
- It is recommended to use in community, buildings or new branch offices but not in large central offices, factories and roadside.
- After the disconnection of Line A and B, the Line A-B, Line A/B-ground AC/DC voltage is about 0V, and the result of below 1V is normal in the test by means of multimeter or 112 test terminal.
- The Line A-B insulation resistance and the Line A/B-ground should be more than 5M Ω .
- The length of subscriber lines can be basically calculated according to the inter-line capacitance of 50Nf/km, or the loop resistance. The DC resistance reference value of the common lines is shown in the table below:

Table 12-11 DC resistance reference value of common lines

Diameter (mm)	0.32	0.4	0.5	0.6	0.8
DC resistance (Ω /km)	236	148	95	65.8	36.6

Before the subscriber line is commissioned, check the quantity of devices being connected in series and parallel on the house line, such as telephones, fax machines, charge registers, extensions of telephone, audio Modem, and IP dialer, and make the detailed records for locating problems in maintenance.

1.1.1.71 Connection, Configuration and Commissioning of User End Devices

1) Connection splitter

The VDSL service is the traditional voice and data services run on a twisted pair, requiring the installation of splitter at the user end to split voice from data. The correct installation of VDSL splitters is a key step in the process of VDSL service commissioning.

The house line should be first connected into the Line port of the VDSL splitter, and all the voice devices should be connected to the Phone port of the splitter and VDSL Modem to the Modem port.



Note

The practice of connecting to any voice devices before the Line port of the splitter should be prohibited, or else, Modem cannot work normally.

The method for correctly connecting the splitter is shown in the figure below:

Figure 12-7 Connection of splitters

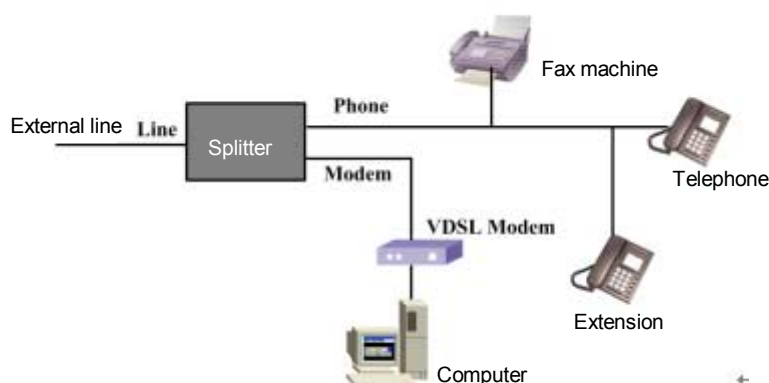

Note

Some Modems are in-built with splitters, and the connection of the ports can be done as shown in the figure above.

2) Connection, configuration and commissioning of Modems

Confirm the normality of lines and the proper installation of central office terminals, and the Line cables and POTS cables having been connected to the distribution frame. Try to make a call for its normal use, if it cannot be made or gets line crossed, the wires may be correctly bonded, and should be done again; if the call can be normally made, the next is to connect, configure and commission the Modem. Take the Modem of the in-built splitter for example, the method is described as follows:

- Connect the Modem with the telephone wire, and connect the network cable to the network adapter of PC.
- Complete the related network configuration and subscriber authentication setting.
- Power on the Modem and wait for over ten seconds, and the SYNC indicator of the Modem is on, showing that the VDSL link has been established.
- Try to access the Internet, if it is possible, it shows the commissioning of VDSL.

Recording the User Information and Relevant Data

For the convenience of the later operation maintenance, the user information and the data for the initially commissioned line connection. For details, see Table 12-9 and 12-13:

Table 12-12 VDSL setting parameters and connection parameter record table

Set the restraint parameters					
VDSL Upstream/d ownstream rate levels	r1.04	Upstream [] Downstream []	Auto- adaptation mode	on	[]
	r2.08	Upstream [] Downstream []		off	[]
	r4.17	Upstream [] Downstream []	Ethernet rate	10M	[]
	r8.33	Upstream [] Downstream []		100M	[]
	r10.04	Upstream [] Downstream []	Duplex mode.	full	[]
	r12.5	Upstream [] Downstream []		half	[]
	r16.67	Upstream [] Downstream []	Modem flow control	on	[]
	rom	Upstream [] Downstream []		off	[]
Others:					
Actual connection parameters					
VDSL Upstream/d ownstream rate	Upstream rate		Auto- adaptation	on	[]
				off	[]
	Downstrea m rate		Ethernet rate	10M	[]
				100M	[]
Duplex mode	full	[]	Modem flow control	on	[]
	half	[]		off	[]
Others					

12.2.3.VDSL Line Maintenance

VDSL Service Common Faults and Handling

1) Unable to make calls and access the Internet

- Confirm the correct and reliable connection of the splitter, VDSL Modem, subscriber terminal PC and telephone.
- Report the line faults to the 112 test terminal, and check the Internet accessing after confirming the telephone service is normal.

2) Able to make calls but cannot access the Internet

(1) Confirm the power supply for the VDSL central office terminal is normal.

The data service is interrupted upon power-off, but the PSTN voice service cannot be affected because the in-built splitter uses the passive working mode.

(2) Check whether the VDSL Link indicators of the ports related to the Modem or VDSL central office terminals is in normal status, and if it is normal, you need to confirm it:

- The connection between the splitter and the VDSL Modem is reliable and correct.

- Whether the line exceeds the recommended distance.
- Whether there are wires other than copper wires in the line, such as iron wires or aluminium wires.
- Whether there are any parallels of long distance in the line.

(3) Check whether the Ethernet LINK indicator of VDSL Modem is normal, if not, please confirm it:

- Check whether the connection between the PC terminal and the network cable of the VDSL Modem.
- Check whether the used network cables are correct or they are parallels.
- Check whether the PC network adapter fails or is improperly configured, such as disabled.

4} Check whether the configuration of the central office terminal is correct.

- Whether the VLAN setting is correct.
- Whether the TAGGED mode of the upstream port is matched with the setting of the peer port.
- Whether the negotiation between the upstream port and the peer interface is normal.
- Confirm the consistency of data configuration between the VDSL equipment and the upper level equipment.

(5) Fault location of the common access mode for accessing the Internet

- Upon accessing the Internet in the PPPoE dialing mode, check the dialing status, and if the connection between the computer and the server is shown as blocked, the physical connection and the data configuration between the VDSL equipment and the upper level equipment should be checked to ensure the smooth connection; if it does not pass the authentication, the correct user name and password should be used.
- Upon using DHCP to dynamically allocate the IP address, observe whether the subscriber can be allocated with the IP address, if not, it shows the incorrect setting of the network adapter. For example, the subscriber end has not been set with automatically obtaining the IP address.
- If the subscriber can obtain the IP address and the ping the external IP address, but cannot access the Internet yet, check whether the DNS and the setting of the proxy server are correct.

3) Able to access the Internet but the speed is slow

- Check the set rate and the actual activation rate of lines, if the activation rate is quite low but the transmission distance is not so long, generally it is the problem of lines.
- Check the result of port negotiation, and the ideal negotiation result can be achieved by setting the related ports and the subscriber network adapter attributes of the central office terminal.
- Check whether the uplink of the central office terminal is connected to HUB, O/E converter and switch, and confirm the correctness of the configuration of these devices.

1.1.1.72 Case Analysis

1) 10M network adapter is connected to Modem, the rate is quite low sometimes.

Usually, when one end of the line in duplex mode is configured as the full duplex mode and the other end is in auto-negotiation mode, the result of the auto-negotiation is half-duplex. The different modes at the two ends would lead to low rate.

Solution: In the case of 10/100M network adapter, two ends are configured as auto-negotiation mode, and they can negotiate to the biggest result, that is, 100M/Full; in the case of 10M network adapter, the two ends are configured the same mode, that is, 10M/Full or 10M/Half.

Case Background

As shown in the figure below, the uplink interface of 3P@C 4450E is connected to PC2, while the downlink interface is connected to a Modem and to PC1. The network adapter of PC1 is a 10M network adapter, set as 10M/Full; PC2 network adapter is in the auto-negotiation mode, set as Auto detect.

Figure 12-8 Networking diagram

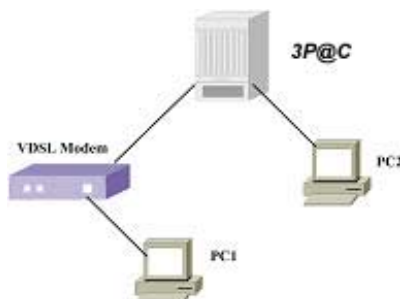

Fault symptom

In application, it is found that the rate is very low upon transmitting files with FTP between PC2 and PC1; check the status of Modem, and the duplex status of Modem is negotiated to 10M/Half.

Analysis and troubleshooting:

Step 1	It can be judged that the cause for low rate is the different duplex modes at the two ends of the line.
Step 2	Configure the duplex modes of Modem and PC1 network adapter as the same, that is 10M/Full or 10M/Half.
Step 3	Transmit via FTP, and the rate becomes higher. This problem is solved.

CHAPTER 13

13. Fault Analysis and Solution

13.1. Problem Location & Information Collection

In usual cases, the system should be timely checked for problem location and solution when it is abnormal. And the information should be collected for relevant personnel for further analysis and solution or serving as the reference documents for the system maintenance.

13.1.1. General Check

Step 1	Record the result information of the following information: show version [all <0-15>]: Show the version information of all/part of boards or cards inserted in 3P@C 4450E show running-time: Show the running time of the system show running-config: Show the running configuration of the system show task: Check whether the task is normally run show slab mod: Check the allocation and use of memory show slab global: Check the use of memory Show sysattack: Check the cases of the system being attacked
--------	--

13.1.2. Layer-2 Check

If some ports on a network segment are blocked, check Layer 2 first:

Step 1	show port {[all <portlist>]}*1	Check the status of ports, the up/down status of ports and the rate, duplex, flow control and auto-negotiation mode of ports.
Step 2	show fdb	View the software FDB table, and whether the MAC address of subscribers and the MAC address of the peer router have been learnt, and the ports and Vlan Name are correct
Step 3	show vlan	Check whether the VLAN configuration of software is correct, especially the correctness of the VLAN configuration with the upstream equipment, including whether the connection port is correctly added and the tag value is correctly configured.

13.1.3. Layer-3 Check

If some network segments cannot be used for L3 forwarding, and no problems are found in the L2 check, it can be conducted:

Step 1	show ip route	Check the content of the route table, the correctness of the route table, and whether the configured static route and the OSPF/RIP route have been learnt and the selection of routes is correct.
Step 2	show interface <ifname>	Check whether the related interfaces are correctly "upped".
Step 3	show ip route cache	Check the correctness of the bottom layer host route table.

13.1.4. Service Check

If the Modem has not been synchronized, the following check should be done:

- Whether the port has been enabled
- For the ADSL access, check the pvc setting using the **show pvc** command.
- Check the setting of ports, and view the configuration information using the command, show port [<portlist>|all|active] [adsl|vdsi] line-config.

13.2. Unstable Service due to Wrong Making of Network Cables

Basic Information

Name of case	Unstable service due to wrong making of network cables
Product name	3P@C 4450E
Module type and version	DS-4TXB
Software version	None

Since the implementing party lacks sufficient knowledge of making network cables, assuming that the linear ordering of the two ends is the same, the actual service cannot be stably run for a long time after being commissioned. For the physical problem location of this kind, the engineers should be careful enough and improve their understanding of the Ethernet auto-negotiation and basic principles of communication.

13.2.1. Common Causes

- Mismatched working modes of the interconnected ports between both parties
- Problem of network adapter
- Problem of network
- Problem of port module

13.2.2. Processing Procedure

Step 1	Show the port configuration of both parties, and check the working mode of their ports in actual circumstances
Step 2	Check whether there is any wrong statistics in the statistical information about ports.
Step 3	Check whether the making of network cables meets the EIA/TIA 568A/B standard. Network cables can be changed if necessary.
Step 4	Do the test of changing the upstream electric interface.

13.2.3. Typical Cases

1.1.1.73 Case 1:

1.1.1.73.1 Background

The phenomenon of intermittent make-break and even no make occurs to the services after interconnection when a certain office uses the electrical interface module and the peer equipment of 3P@C 4450E for interconnection via the UTP cable.

1.1.1.73.2 Fault symptom

The phenomenon of intermittent make-break and even no make occurs to the services after interconnection when a certain office uses the LAN of DSLAM for interconnection. Check the data configuration and the physical connection for correctness, the LINK indicator of the network cable is green. And the problem of upper-layer network communication has been excluded.

1.1.1.73.3 Analysis and troubleshooting:

Step 1	Check the port modes of the equipment at both ends, they are all the 10/100M auto-adaptation mode, and the result of the interconnection is 100M.
Step 2	View the statistical information of the ports, and find a number of CRC Error alarms.
Step 3	Upon obtaining the consent from the customer, check the network cables used for the upper connection, it is found that the network cables have not been made according to the standard linear ordering, and only the color labels of both parties are made the same.
Step 4	After we use the EIA/TIA 568B standard linear ordering mode to remake the network cable, the service becomes normal.

1.1.1.73.4 Summary

A minute problem can often affect the whole work. A low-grade mistake (of not understanding the basic method and standard for making the network cables) made by the implementing party leads to a seemingly weird problem. Such a problem as intermittent make-break should be solved in basic principles.



Note

The standard linear ordering of network cables: Yellowish white, yellow, greenish white, blue, bluish white, green, brownish white and brown, and the same at both ends. This kind of network cables can be used for the connection of 10M/100M lines. While the practice of making the linear ordering of both ends consistent can only applied to the connection of 10M lines. The ports auto-negotiated to 100M, however, is connected using the 10M network cable, the packets are inevitably to collide, which leads to the intermittent make-break or not make of the service.

CHAPTER 14

14. Operation Instructions for the Auxiliary Devices

14.1. Use of AC/DC Converter

In usual cases, 3P@C 4450E uses the DC -48V for power supply. In some application environments that the DC power supply is not available, however, AC220V is needed, so the AC/DC converter is the choice. At present, the AC/DC converter for choice is the HD4825 rectification module converter.

 prompt	<ol style="list-style-type: none">1. For the detailed description of HD4825, refer to HD4825 Rectification Module Use. Here, the connection of power supply for the Hammer10000 AC power supply is the main concern.2. Other 4825 converters can also be used.
---	---

The procedure of power supply connection in the 3P@C 4450E AC power supply is as follows:

Step 1	For 3P@C 4450EV2.00, Use the cable connector matched with HD4825, and connect the “+” pole (red wire) for the HD4825 DC output with the BGND (black wire) for 3P@C 4450E DC power input wire connector; connect the “-” pole (black wire) for HD4825 DC output with -48V (blue wire) for 3P@C 4450E0 DC power input wire connector.
 prompt	For 3P@C 4450EV1.00, Use the cable connector matched with HD4825, and connect the “+” pole (red wire) for the HD4825 DC output with the BGND (black wire) for 3P@C 4450E DC power input wire connector; connect the “-” pole (black wire) for HD4825 DC output with -48V (red wire) for 3P@C 4450E0 DC power input wire connector.
Step 2	Insert the 3P@C 4450 ^E DC power input wire connector into the corresponding connector of 3P@C 4450E backplane, and insert the HD4825 connector into the DC output port at the back of HD4825. The description of 3P@C 4450E backplane power connector and the DC output port at the back of HD4825 is shown in Figure 14-1.
Step 3	Connect the 220V AC power supply to HD4825, as shown in Figure 14-2.

Figure 1-2 Description of 3P@C 4450E backplane power connector and the DC output port at the back of HD4825

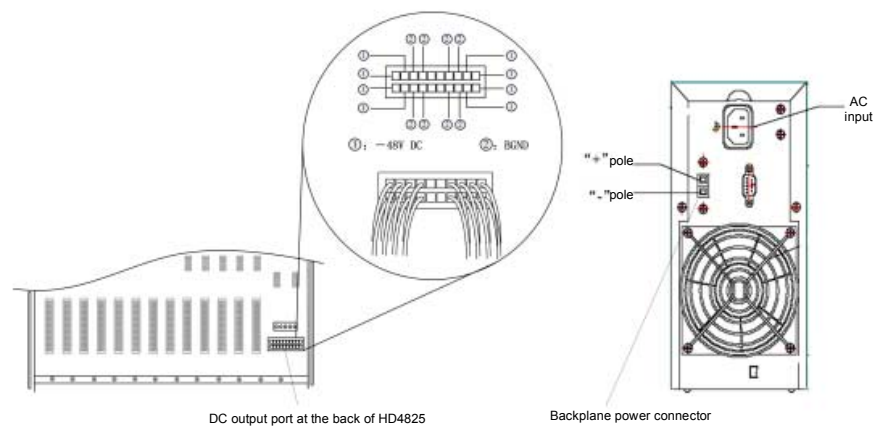
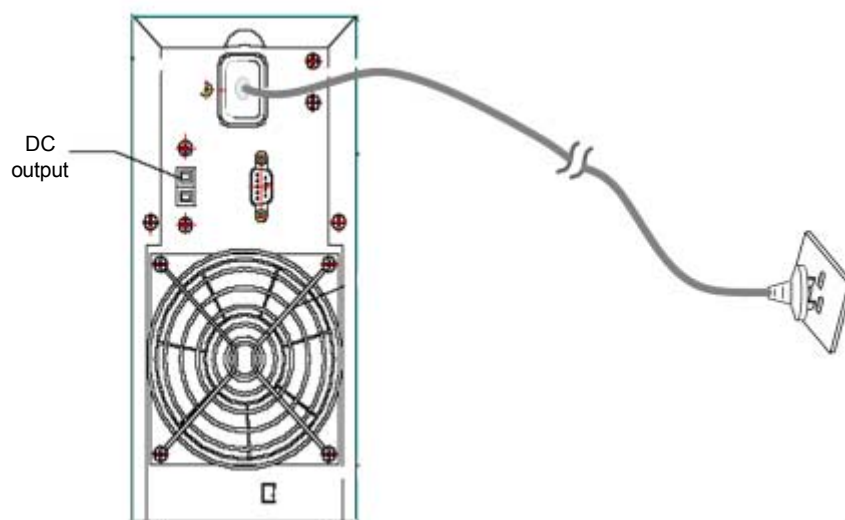

Figure 1-3 Connection between HD4825 and AC power supply



APPENDIX

Common Troubleshooting & Relevant Knowledge

A. Diagnosis of Common Faults

Fault symptom	Fault cause	Solution
All the indicators are off after power-on.	Power connection is wrong or power supply is abnormal.	Check the power cable and the socket.
LINK indicator is off.	Network cable is damaged or loosely connected. The type of network cable is wrong or the network cable is too long, whose length exceeds the permitted range.	Replace the network cable.
LINK indicator flashes	The wiring of the network cable does not conform to the standards. The network cable is too long and its length exceeds permitted range.	Replace the network cable or re-make network cables.
The ACT indicator flashes quickly and the network is blocked.	The wiring of the network cable does not conform to the standards.	Replace the network cables or re-make them.
The network can be pinged, but the transmission rate slows down and packet loss occurs.	The working mode of the switch does not match that of the Ethernet port at the network terminal.	Configure the working mode of the Ethernet ports so that it matches the switch or set it in the adaptive working mode.
The network can be pinged at a certain port, but not when the network cable is changed to another port.	If the equipment connected to the port does not send data after the network cable is changed to another network port, the switch will not be able to learn the new address, therefore this port will be blocked temporarily.	In about dozens of seconds, the address table of the switch will be updated, and this phenomenon will automatically disappear. Or sending data from this port will also make the switch update its address table immediately.
All ACT indicators are flashing and the network rate slows down.	Broadcast storm.	1. Check if there is loop on the network and properly configure the network. 2. Check if any site is sending a large amount of broadcast packets.
It stops working after a period of normal work.	The power supply works abnormally. It is overheated.	1. Check if the power supply is properly connected and the voltage is too low or too high. 2. Check the surroundings and see if the vent is empty and the fans of the switch operate normally.
The system cannot be accessed through Telnet	The network connection is incorrect. The IP address is not configured.	Check the network connection. Access the system via the serial port and configure the IP address properly.

B. Glossary

This section gives a brief description of some terms.

Terms	Definition
Backbone	The network that serves as the main path for traffic transmission between network segments.
Bandwidth	Frequency bandwidth of the network channel, which usually means the data transmission capability of the network channel.
10Base-T	An abbreviated term in IEEE 802.3, which refers to the 10Mbps Ethernet over Category-3 or better twisted pair based on Manchester signal coding.
100Base-TX	An abbreviated term in IEEE 802.3, which refers to the 100Mbps fast Ethernet over two Category-5 twisted pairs based on 4B/5B signal coding.
100Base-FX	An abbreviated terminology as given in IEEE 802.3, indicating 100 Mbps fast Ethernet over optical fiber cables based on 4B/5B signal coding.
1000Base-LX	An abbreviated terminology as given in IEEE 802.3, indicating 1000 Mbps Ethernet over the long wavelength optical fibers based on 8B/10B signal coding.
1000Base-SX	An abbreviated terminology as given in IEEE 802.3, indicating 1000Mbps Ethernet over short wavelength optical fibers based on 8B/10B signal coding.
Auto negotiation	The auto negotiation mode means the interface automatically adjusts its speed to the highest public level, that is, the fastest possible speed and duplex mode between the two ends of the line, according to the connection rate and duplex mode of the equipment on the other end.
Full-duplex	A communication method, which permits simultaneously receiving and sending data.
Semi-duplex	A communication method, which only permits either data sending or receiving at a moment.
Collision	Normal event on the Ethernet in semi-duplex working mode, which indicates two or more sites access the same channel simultaneously.
Broadcast storm	A large amount of broadcast frames on the Ethernet causes network congestion and thus leads to network failure.
RJ-45	A kind of 8-pin module connector for twisted pair links.
MDI	Medium-related interface, which is the name of the connector for establishing physical and electrical connections between the transceiver and medium segments.
MDIX	Crossed medium-related interface, which sends the signal from one equipment to the signal-receiving side of the other equipment and vice versa.
SNMP	Simple Network Management Protocol
STP	Spanning Tree Protocol
VLAN	Virtual LAN

c. Fiber-related Knowledge

The center of an optical fiber is a glass core for optical transmission. The core is surrounded by a layer of glass envelope, whose refractive index is lower than that of the core to keep the optical fiber within the core. Out of the glass envelope is a layer of thin plastic sheath to protect the envelope. The high reliability, transmission quality and gradual adoption of new technologies in design and manufacturing make the optical fiber cables have an even wider application range.

C.1 Multi-Mode and Single-Mode Optical Fiber Cables

The optical fiber system can be divided into two categories according to the optical transmission mode: multi-mode and single-mode. A single-mode optical fiber cable has a very small core (4 μm to 10 μm) and can only transmit signals in single mode at a given wavelength. Its transmission bandwidth is wide and the transmission capacity is quite large. You can tell single-mode fiber cables from multi-mode fiber cables easily based on the size of their cores.

Multi-mode fibers can support multiple transmission modes on a given wavelength. In multi-mode transmission, different modes of optical signals are transmitted at different rates through the same fiber. This can result in phase difference, which, in turn, causes transmission distortion. And therefore, the frequency band that a multi-mode optical fiber can provide is restricted. Two specifications are available now for the cores of multi-mode optical fibers: 62.5 μm and 50 μm . In ISO/IEC 11801, both the two modes are recognized transmission media.

C.2 Wavelength range of the optical fiber

Optical wave bands adopted for optical fiber cabling: 800nm to 900nm short wave band, 1250nm to 1350nm long wave band and 1500nm to 1600nm long wave band.

In these bands, the optical fiber performs best at the central wavelength of each band. Therefore the operating wavelength of the multimode optical fiber is 850nm or 1300nm and the operating wavelength of the single mode optical fiber is 1310nm or 1550nm.

C.3 Optical Fiber Connector

The optical connector, a demountable device, is defined by International Telecommunication Union (ITU) as fiber optic passive component that connects stably but not permanently two or more optical fibers. In March 1992, Study Group VI of CCITT (Consultative Committee for International Telegraphy and Telephony) formally adopted the definition. The optical connector is an indispensable passive device in optical communication system and makes the demountable connection of optical channels possible. The optical connector has many kinds. For example:

- FC optical connector, round and threaded
- ST optical connector, plug-in and round-head
- SC optical connector, square-head
- MT-RJ square optical connector capable of both receiving and sending

The following is the appearance of the SC connector and MT-RJ connector, as shown in Figure C-1 and C-2:

Figure C-1 Appearance of the SC connector

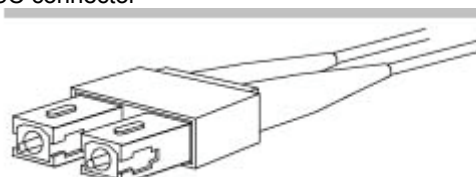

Figure C-2 Appearance of the RJ connector



SAGEM SA may, at any time and without notice, make changes or improvements to the products and services offered and/or cease producing or commercialising them. The SAGEM logo and trademark are the property of SAGEM SA.

SAGEM SA Networks Division

Phone +33 1 53 23 18 16 Fax +33 1 58 12 42 95
www.sagem.com

Head office : Le Ponant de Paris - 27, rue Leblanc - 75512 PARIS CEDEX 15 - FRANCE
Société anonyme à directoire et conseil de surveillance au capital de 35 500 000 € - 562 082 909 R.C.S PARIS

